



CD-ROM INCLUDED

PRENTICE
HALL

ANALYSIS, SYNTHESIS, AND DESIGN OF CHEMICAL PROCESSES

FOURTH EDITION

RICHARD TURTON • RICHARD C. BAILIE • WALLACE B. WHITING
JOSEPH A. SHAEIWITZ • DEBANGSU BHATTACHARYYA

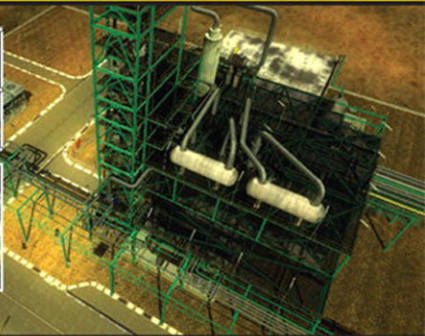
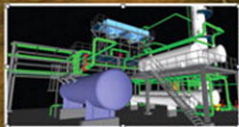

PRENTICE HALL INTERNATIONAL SERIES IN THE
PHYSICAL AND CHEMICAL ENGINEERING SCIENCES

FREE SAMPLE CHAPTER

SHARE WITH OTHERS



**Analysis, Synthesis,
and Design
of Chemical Processes**

Fourth Edition

Prentice Hall International Series in the Physical and Chemical Engineering Sciences

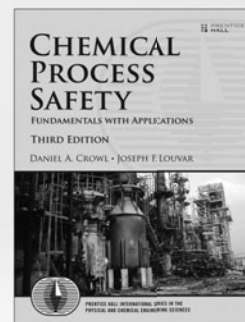
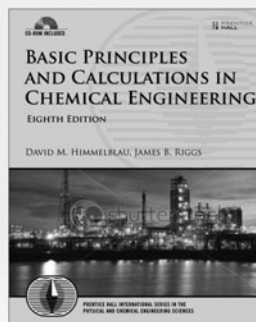
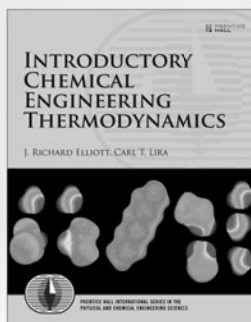
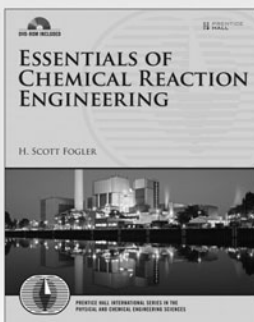

 PRENTICE
HALL

Visit informit.com/ph/physandchem
for a complete list of available publications.

The Prentice Hall International Series in the Physical and Chemical Engineering Sciences had its auspicious beginning in 1956 under the direction of Neal R. Amundsen. The series comprises the most widely adopted college textbooks and supplements for chemical engineering education. Books in this series are written by the foremost educators and researchers in the field of chemical engineering.



Make sure to connect with us!
informit.com/socialconnect



informIT.com
THE TRUSTED TECHNOLOGY LEARNING SOURCE

Safari
Books Online

Analysis, Synthesis, and Design of Chemical Processes

Fourth Edition

Richard Turton

Richard C. Bailie

Wallace B. Whiting

Joseph A. Shaeiwitz

Debangsu Bhattacharyya



PRENTICE
HALL

Upper Saddle River, NJ • Boston • Indianapolis • San Francisco
New York • Toronto • Montreal • London • Munich • Paris • Madrid
Capetown • Sydney • Tokyo • Singapore • Mexico City

Many of the designations used by manufacturers and sellers to distinguish their products are claimed as trademarks. Where those designations appear in this book, and the publisher was aware of a trademark claim, the designations have been printed with initial capital letters or in all capitals.

The authors and publisher have taken care in the preparation of this book, but make no expressed or implied warranty of any kind and assume no responsibility for errors or omissions. No liability is assumed for incidental or consequential damages in connection with or arising out of the use of the information or programs contained herein.

The publisher offers excellent discounts on this book when ordered in quantity for bulk purchases or special sales, which may include electronic versions and/or custom covers and content particular to your business, training goals, marketing focus, and branding interests. For more information, please contact:

U.S. Corporate and Government Sales
(800) 382-3419
corpsales@pearsontechgroup.com

For sales outside the United States please contact:

International Sales
international@pearson.com

Visit us on the Web: informit.com/ph

Library of Congress Cataloging-in-Publication Data is on file with the Library of Congress.

Copyright © 2012 Pearson Education, Inc.

All rights reserved. Printed in the United States of America. This publication is protected by copyright, and permission must be obtained from the publisher prior to any prohibited reproduction, storage in a retrieval system, or transmission in any form or by any means, electronic, mechanical, photocopying, recording, or likewise. To obtain permission to use material from this work, please submit a written request to Pearson Education, Inc., Permissions Department, One Lake Street, Upper Saddle River, New Jersey 07458, or you may fax your request to (201) 236-3290.

ISBN-13: 978-0-13-261812-0

ISBN-10: 0-13-261812-5

Text printed in the United States on recycled paper at Edwards Brothers Malloy in Ann Arbor, Michigan.

Second printing, September 2013

Acquisitions Editor: Bernard Goodwin

Managing Editor: John Fuller

Project Editor: Elizabeth Ryan

Copy Editor: Barbara Wood

Indexer: Jack Lewis

Proofreader: Linda Begley

Cover Designer: Alan Clements

Compositor: Laserwords Pvt. Ltd.

Contents

Material on the CD-ROM xix

Preface xxiii

About the Authors xxvii

List of Nomenclature xxix

SECTION I CONCEPTUALIZATION AND ANALYSIS OF CHEMICAL PROCESSES 1

Chapter 1 Diagrams for Understanding Chemical Processes 3

What You Will Learn 3

1.1 Block Flow Diagram (BFD) 5

1.1.1 *Block Flow Process Diagram* 5

1.1.2 *Block Flow Plant Diagram* 6

1.2 Process Flow Diagram (PFD) 8

1.2.1 *Process Topology* 9

1.2.2 *Stream Information* 12

1.2.3 *Equipment Information* 16

1.2.4 *Combining Topology, Stream Data, and Control Strategy to Give a PFD* 18

1.3 Piping and Instrumentation Diagram (P&ID) 21

1.4 Additional Diagrams 26

1.5 Three-Dimensional Representation of a Process 27

1.6 The 3-D Plant Model 35

1.7 Operator and 3-D Immersive Training Simulators 37

1.7.1 *Operator Training Simulators (OTS)* 37

1.7.2 *3-D Immersive Training Simulators (ITS)* 38

1.7.3 *Linking the ITS with an OTS* 40

1.8 Summary 43

What You Should Have Learned 43

References 44

Short Answer Questions 44

Problems 44

Chapter 2 The Structure and Synthesis of Process Flow Diagrams 49

What You Will Learn 49

2.1 Hierarchy of Process Design 49

2.2	Step 1—Batch versus Continuous Process	50
2.3	Step 2—The Input/Output Structure of the Process	54
2.3.1	<i>Process Concept Diagram</i>	54
2.3.2	<i>The Input/Output Structure of the Process Flow Diagram</i>	55
2.3.3	<i>The Input/Output Structure and Other Features of the Generic Block Flow Process Diagram</i>	57
2.3.4	<i>Other Considerations for the Input/Output Structure of the Process Flowsheet</i>	60
2.3.5	<i>What Information Can Be Determined Using the Input/Output Diagram for a Process?</i>	62
2.4	Step 3—The Recycle Structure of the Process	64
2.4.1	<i>Efficiency of Raw Material Usage</i>	65
2.4.2	<i>Identification and Definition of the Recycle Structure of the Process</i>	66
2.4.3	<i>Other Issues Affecting the Recycle Structure That Lead to Process Alternatives</i>	70
2.5	Step 4—General Structure of the Separation System	78
2.6	Step 5—Heat-Exchanger Network or Process Energy Recovery System	78
2.7	Information Required and Sources	78
2.8	Summary	78
	What You Should Have Learned	80
	References	80
	Short Answer Questions	81
	Problems	81

Chapter 3 Batch Processing 87

	What You Will Learn	87
3.1	Design Calculations for Batch Processes	87
3.2	Gantt Charts and Scheduling	93
3.3	Nonoverlapping Operations, Overlapping Operations, and Cycle Times	94
3.4	Flowshop and Jobshop Plants	97
3.4.1	<i>Flowshop Plants</i>	97
3.4.2	<i>Jobshop Plants</i>	99
3.5	Product and Intermediate Storage and Parallel Process Units	102
3.5.1	<i>Product Storage for Single-Product Campaigns</i>	102
3.5.2	<i>Intermediate Storage</i>	104
3.5.3	<i>Parallel Process Units</i>	106
3.6	Design of Equipment for Multiproduct Batch Processes	107
3.7	Summary	109
	What You Should Have Learned	110
	References	110
	Short Answer Questions	110
	Problems	110

Chapter 4 Chemical Product Design 115

- What You Will Learn 115
- 4.1 Strategies for Chemical Product Design 116
- 4.2 Needs 117
- 4.3 Ideas 119
- 4.4 Selection 120
- 4.5 Manufacture 122
- 4.6 Batch Processing 123
- 4.7 Economic Considerations 123
- 4.8 Summary 123
 - What You Should Have Learned 124
 - References 124

Chapter 5 Tracing Chemicals through the Process Flow Diagram 125

- What You Will Learn 125
- 5.1 Guidelines and Tactics for Tracing Chemicals 125
- 5.2 Tracing Primary Paths Taken by Chemicals in a Chemical Process 126
- 5.3 Recycle and Bypass Streams 132
- 5.4 Tracing Nonreacting Chemicals 135
- 5.5 Limitations 135
- 5.6 Written Process Description 136
- 5.7 Summary 137
 - What You Should Have Learned 137
 - Problems 138

Chapter 6 Understanding Process Conditions 139

- What You Will Learn 139
- 6.1 Conditions of Special Concern for the Operation of Separation and Reactor Systems 140
 - 6.1.1 Pressure 140
 - 6.1.2 Temperature 141
- 6.2 Reasons for Operating at Conditions of Special Concern 142
- 6.3 Conditions of Special Concern for the Operation of Other Equipment 146
- 6.4 Analysis of Important Process Conditions 150
 - 6.4.1 Evaluation of Reactor R-101 151
 - 6.4.2 Evaluation of High-Pressure Phase Separator V-102 156
 - 6.4.3 Evaluation of Large Temperature Driving Force in Exchanger E-101 156
 - 6.4.4 Evaluation of Exchanger E-102 156
 - 6.4.5 Pressure Control Valve on Stream 8 157
 - 6.4.6 Pressure Control Valve on Stream from V-102 to V-103 157
- 6.5 Summary 157
 - What You Should Have Learned 157
 - References 158
 - Short Answer Questions 158
 - Problems 158

SECTION II ENGINEERING ECONOMIC ANALYSIS OF CHEMICAL PROCESSES 161**Chapter 7 Estimation of Capital Costs 163**

- What You Will Learn 163
- 7.1 Classifications of Capital Cost Estimates 164
- 7.2 Estimation of Purchased Equipment Costs 167
 - 7.2.1 *Effect of Capacity on Purchased Equipment Cost* 167
 - 7.2.2 *Effect of Time on Purchased Equipment Cost* 171
- 7.3 Estimating the Total Capital Cost of a Plant 172
 - 7.3.1 *Lang Factor Technique* 176
 - 7.3.2 *Module Costing Technique* 177
 - 7.3.3 *Bare Module Cost for Equipment at Base Conditions* 177
 - 7.3.4 *Bare Module Cost for Non-Base-Case Conditions* 181
 - 7.3.5 *Combination of Pressure and MOC Information to Give the Bare Module Factor, F_{BM} and Bare Module Cost, C_{BM}* 191
 - 7.3.6 *Algorithm for Calculating Bare Module Costs* 191
 - 7.3.7 *Grassroots and Total Module Costs* 193
 - 7.3.8 *A Computer Program (CAPCOST) for Capital Cost Estimation Using the Equipment Module Approach* 196
- 7.4 Summary 198
 - What You Should Have Learned 198
 - References 198
 - Short Answer Questions 199
 - Problems 200

Chapter 8 Estimation of Manufacturing Costs 203

- What You Will Learn 203
- 8.1 Factors Affecting the Cost of Manufacturing a Chemical Product 203
- 8.2 Cost of Operating Labor 208
- 8.3 Utility Costs 209
 - 8.3.1 *Background Information on Utilities* 209
 - 8.3.2 *Calculation of Utility Costs* 211
- 8.4 Raw Material Costs 223
- 8.5 Yearly Costs and Stream Factors 225
- 8.6 Estimating Utility Costs from the PFD 225
- 8.7 Cost of Treating Liquid and Solid Waste Streams 228
- 8.8 Evaluation of Cost of Manufacture for the Production of Benzene via the Hydrodealkylation of Toluene 228
- 8.9 Summary 229
 - What You Should Have Learned 230
 - References 230
 - Short Answer Questions 230
 - Problems 231

Chapter 9 Engineering Economic Analysis 233

- What You Will Learn 233
- 9.1 Investments and the Time Value of Money 234
- 9.2 Different Types of Interest 238

9.2.1	<i>Simple Interest</i>	238
9.2.2	<i>Compound Interest</i>	238
9.2.3	<i>Interest Rates Changing with Time</i>	239
9.3	Time Basis for Compound Interest Calculations	240
9.3.1	<i>Effective Annual Interest Rate</i>	240
9.3.2	<i>Continuously Compounded Interest</i>	241
9.4	Cash Flow Diagrams	241
9.4.1	<i>Discrete Cash Flow Diagram</i>	242
9.4.2	<i>Cumulative Cash Flow Diagram</i>	244
9.5	Calculations from Cash Flow Diagrams	245
9.5.1	<i>Annuities—A Uniform Series of Cash Transactions</i>	246
9.5.2	<i>Discount Factors</i>	247
9.6	Inflation	250
9.7	Depreciation of Capital Investment	253
9.7.1	<i>Fixed Capital, Working Capital, and Land</i>	254
9.7.2	<i>Different Types of Depreciation</i>	254
9.7.3	<i>Current Depreciation Method: Modified Accelerated Cost Recovery System (MACRS)</i>	258
9.8	Taxation, Cash Flow, and Profit	259
9.9	Summary	262
	What You Should Have Learned	262
	References	262
	Short Answer Questions	263
	Problems	263

Chapter 10 Profitability Analysis 269

	What You Will Learn	269
10.1	A Typical Cash Flow Diagram for a New Project	269
10.2	Profitability Criteria for Project Evaluation	271
	10.2.1 <i>Nondiscounted Profitability Criteria</i>	271
	10.2.2 <i>Discounted Profitability Criteria</i>	275
10.3	Comparing Several Large Projects: Incremental Economic Analysis	279
10.4	Establishing Acceptable Returns from Investments: The Concept of Risk	282
10.5	Evaluation of Equipment Alternatives	283
	10.5.1 <i>Equipment with the Same Expected Operating Lives</i>	283
	10.5.2 <i>Equipment with Different Expected Operating Lives</i>	284
10.6	Incremental Analysis for Retrofitting Facilities	289
	10.6.1 <i>Nondiscounted Methods for Incremental Analysis</i>	289
	10.6.2 <i>Discounted Methods for Incremental Analysis</i>	291
10.7	Evaluation of Risk in Evaluating Profitability	293
	10.7.1 <i>Forecasting Uncertainty in Chemical Processes</i>	294
	10.7.2 <i>Quantifying Risk</i>	298
10.8	Profit Margin Analysis	310
10.9	Summary	311
	What You Should Have Learned	311
	References	312
	Short Answer Questions	312
	Problems	312

SECTION III SYNTHESIS AND OPTIMIZATION OF CHEMICAL PROCESSES 327**Chapter 11 Utilizing Experience-Based Principles to Confirm the Suitability of a Process Design 331**

What You Will Learn 331

11.1 The Role of Experience in the Design Process 332

11.1.1 *Introduction to Technical Heuristics and Shortcut Methods* 33211.1.2 *Maximizing the Benefits Obtained from Experience* 333

11.2 Presentation of Tables of Technical Heuristics and Guidelines 335

11.3 Summary 338

What You Should Have Learned 356

References 356

Problems 356

Chapter 12 Synthesis of the PFD from the Generic BFD 357

What You Will Learn 357

12.1 Information Needs and Sources 358

12.1.1 *Interactions with Other Engineers and Scientists* 35812.1.2 *Reaction Kinetics Data* 35812.1.3 *Physical Property Data* 359

12.2 Reactor Section 360

12.3 Separator Section 362

12.3.1 *General Guidelines for Choosing Separation Operations* 36212.3.2 *Sequencing of Distillation Columns for Simple Distillation* 36412.3.3 *Azeotropic Distillation* 367

12.4 Reactor Feed Preparation and Separator Feed Preparation Sections 377

12.5 Recycle Section 378

12.6 Environmental Control Section 378

12.7 Major Process Control Loops 379

12.8 Flow Summary Table 379

12.9 Major Equipment Summary Table 380

12.10 Summary 380

What You Should Have Learned 380

References 381

Problems 382

Chapter 13 Synthesis of a Process Using a Simulator and Simulator Troubleshooting 385

What You Will Learn 385

13.1 The Structure of a Process Simulator 386

13.2 Information Required to Complete a Process Simulation: Input Data 389

13.2.1 *Selection of Chemical Components* 38913.2.2 *Selection of Physical Property Models* 39013.2.3 *Selection and Input of Flowsheet Topology* 39213.2.4 *Selection of Feed Stream Properties* 39313.2.5 *Selection of Equipment Parameters* 393

13.2.6	<i>Selection of Output Display Options</i>	400
13.2.7	<i>Selection of Convergence Criteria and Running a Simulation</i>	400
13.3	Handling Recycle Streams	401
13.4	Choosing Thermodynamic Models	403
13.4.1	<i>Pure-Component Properties</i>	404
13.4.2	<i>Enthalpy</i>	404
13.4.3	<i>Phase Equilibria</i>	405
13.4.4	<i>Using Thermodynamic Models</i>	412
13.5	Case Study: Toluene Hydrodealkylation Process	414
13.6	Electrolyte Systems Modeling	416
13.6.1	<i>Fundamentals of Modeling Electrolyte Systems</i>	416
13.6.2	<i>Steps Needed to Build the Model of an Aqueous Electrolyte System and the Estimation of Parameters</i>	423
13.7	Solids Modeling	429
13.7.1	<i>Physical Properties</i>	429
13.7.2	<i>Parameter Requirements for Solids Model</i>	431
	What You Should Have Learned	434
Appendix 13.1	Calculation of Excess Gibbs Energy for Electrolyte Systems	434
Appendix 13.2	Steps to Build a Model of a Distillation Column for an Electrolyte System Using a Rate-Based Simulation with a Film Model for Mass Transfer, the Parameters Required at Each Stage, and Possible Sources of These Parameters	437
13.8	Summary	440
	References	441
	Short Answer Questions	444
	Problems	444

Chapter 14 Process Optimization 451

	What You Will Learn	451
14.1	Background Information on Optimization	451
14.1.1	<i>Common Misconceptions</i>	453
14.1.2	<i>Estimating Problem Difficulty</i>	455
14.1.3	<i>Top-Down and Bottom-Up Strategies</i>	455
14.1.4	<i>Communication of Optimization Results</i>	456
14.2	Strategies	457
14.2.1	<i>Base Case</i>	457
14.2.2	<i>Objective Functions</i>	458
14.2.3	<i>Analysis of the Base Costs</i>	459
14.2.4	<i>Identifying and Prioritizing Key Decision Variables</i>	460
14.3	Topological Optimization	461
14.3.1	<i>Introduction</i>	461
14.3.2	<i>Elimination of Unwanted Nonhazardous By-products or Hazardous Waste Streams</i>	462
14.3.3	<i>Elimination and Rearrangement of Equipment</i>	463
14.3.4	<i>Alternative Separation Schemes and Reactor Configurations</i>	466
14.4	Parametric Optimization	467
14.4.1	<i>Single-Variable Optimization: A Case Study on T-201, the DME Separation Column</i>	468

- 14.4.2 *Two-Variable Optimization: The Effect of Pressure and Reflux Ratio on T-201, the DME Separation Column* 470
- 14.4.3 *Flowsheet Optimization Using Key Decision Variables* 473
- 14.5 Lattice Search Techniques versus Response Surface Techniques 478
- 14.6 Process Flexibility and the Sensitivity of the Optimum 479
- 14.7 Optimization in Batch Systems 479
 - 14.7.1 *Problem of Scheduling Equipment* 479
 - 14.7.2 *Problem of Optimum Cycle Time* 484
- 14.8 Summary 487
 - What You Should Have Learned 487
 - References 487
 - Short Answer Questions 488
 - Problems 488

Chapter 15 Pinch Technology 499

- What You Will Learn 499
- 15.1 Introduction 499
- 15.2 Heat Integration and Network Design 500
- 15.3 Composite Temperature-Enthalpy Diagram 514
- 15.4 Composite Enthalpy Curves for Systems without a Pinch 516
- 15.5 Using the Composite Enthalpy Curve to Estimate Heat-Exchanger Surface Area 517
- 15.6 Effectiveness Factor (F) and the Number of Shells 521
- 15.7 Combining Costs to give the EAOC for the Network 526
- 15.8 Other Considerations 527
 - 15.8.1 *Materials of Construction and Operating Pressure Issues* 528
 - 15.8.2 *Problems with Multiple Utilities* 530
 - 15.8.3 *Handling Streams with Phase Changes* 530
- 15.9 Heat-Exchanger Network Synthesis Analysis and Design (HENSAD) Program 532
- 15.10 Mass-Exchange Networks 532
- 15.11 Summary 541
 - What You Should Have Learned 542
 - References 542
 - Short Answer Questions 543
 - Problems 543

Chapter 16 Advanced Topics Using Steady-State Simulators 551

- What You Will Learn 551
- 16.1 Why the Need for Advanced Topics in Steady-State Simulation? 552
- 16.2 User-Added Models 552
 - 16.2.1 *Unit Operation Models* 553
 - 16.2.2 *User Thermodynamic and Transport Models* 555
 - 16.2.3 *User Kinetic Models* 558
- 16.3 Solution Strategy for Steady-State Simulations 562
 - 16.3.1 *Sequential Modular (SM)* 562
 - 16.3.2 *Equation-Oriented (EO)* 576
 - 16.3.3 *Simultaneous Modular (SMod)* 578

16.4	Studies with the Steady-State Simulation	581
16.4.1	<i>Sensitivity Studies</i>	581
16.4.2	<i>Optimization Studies</i>	581
16.5	Estimation of Physical Property Parameters	586
16.6	Summary	589
	What You Should Have Learned	590
	References	590
	Short Answer Questions	591
	Problems	592
Chapter 17	Using Dynamic Simulators in Process Design	601
	What You Will Learn	601
17.1	Why Is There a Need for Dynamic Simulation?	602
17.2	Setting Up a Dynamic Simulation	603
17.2.1	<i>Step 1: Topological Change in the Steady-State Simulation</i>	603
17.2.2	<i>Step 2: Equipment Geometry and Size</i>	607
17.2.3	<i>Step 3: Additional Dynamic Data/Dynamic Specification</i>	608
17.3	Dynamic Simulation Solution Methods	618
17.3.1	<i>Initialization</i>	618
17.3.2	<i>Solution of the DAE System</i>	619
17.4	Process Control	624
17.5	Summary	632
	What You Should Have Learned	632
	References	633
	Short Answer Questions	633
	Problems	634
Chapter 18	Regulation and Control of Chemical Processes with Applications Using Commercial Software	641
	What You Will Learn	641
18.1	A Simple Regulation Problem	642
18.2	The Characteristics of Regulating Valves	643
18.3	Regulating Flowrates and Pressures	646
18.4	The Measurement of Process Variables	649
18.5	Common Control Strategies Used in Chemical Processes	649
18.5.1	<i>Feedback Control and Regulation</i>	649
18.5.2	<i>Feed-Forward Control and Regulation</i>	651
18.5.3	<i>Combination Feedback and Feed-Forward Control</i>	653
18.5.4	<i>Cascade Regulation</i>	654
18.5.5	<i>Ratio Control</i>	655
18.5.6	<i>Split-Range Control</i>	657
18.6	Exchanging Heat and Work between Process and Utility Streams	660
18.6.1	<i>Increasing the Pressure of a Process Stream and Regulating Its Flowrate</i>	660
18.6.2	<i>Exchanging Heat between Process Streams and Utilities</i>	662
18.6.3	<i>Exchanging Heat between Process Streams</i>	666
18.7	Logic Control	666
18.8	Advanced Process Control	669

18.8.1	<i>Statistical Process Control (SPC)</i>	669
18.8.2	<i>Model-Based Control</i>	670
18.9	Case Studies	670
18.9.1	<i>The Cumene Reactor, R-801</i>	671
18.9.2	<i>A Basic Control System for a Binary Distillation Column</i>	672
18.9.3	<i>A More Sophisticated Control System for a Binary Distillation Column</i>	675
18.10	Putting It All Together: The Operator Training Simulator (OTS)	676
18.11	Summary	677
	What You Should Have Learned	677
	References	678
	Problems	678

SECTION IV ANALYSIS OF PROCESS PERFORMANCE 683

Chapter 19 Process Input/Output Models 685

	What You Will Learn	685
19.1	Representation of Process Inputs and Outputs	686
19.2	Analysis of the Effect of Process Inputs on Process Outputs	689
19.3	A Process Example	690
19.4	Summary	691
	What You Should Have Learned	692
	Problems	692

Chapter 20 Tools for Evaluating Process Performance 693

	What You Will Learn	693
20.1	Key Relationships	693
20.2	Thinking with Equations	694
20.2.1	<i>GENI</i>	695
20.2.2	<i>Predicting Trends</i>	695
20.3	Base-Case Ratios	696
20.4	Analysis of Systems Using Controlling Resistances	698
20.5	Graphical Representations	700
20.5.1	<i>The Moody Diagram for Friction Factors</i>	700
20.5.2	<i>The System Curve for Frictional Losses</i>	700
20.5.3	<i>The T-Q Diagram for Heat Exchangers</i>	702
20.6	Summary	704
	What You Should Have Learned	705
	References	705
	Problems	705

Chapter 21 Performance Curves for Individual Unit Operations 707

	What You Will Learn	707
21.1	Application to Heat Transfer	709
21.2	Application to Fluid Flow	714
21.2.1	<i>Pump and System Curves</i>	714
21.2.2	<i>Regulating Flowrates</i>	720

21.2.3	<i>Reciprocating or Positive Displacement Pumps</i>	723
21.2.4	<i>Net Positive Suction Head</i>	723
21.2.5	<i>Compressors</i>	727
21.3	Application to Separation Problems	728
21.3.1	<i>Separations with Mass Separating Agents</i>	728
21.3.2	<i>Distillation</i>	733
21.4	Summary	740
	What You Should Have Learned	741
	References	741
	Short Answer Questions	741
	Problems	743
Chapter 22	Performance of Multiple Unit Operations	749
	What You Will Learn	749
22.1	Analysis of a Reactor with Heat Transfer	749
22.2	Performance of a Distillation Column	754
22.3	Performance of a Heating Loop	759
22.4	Performance of the Feed Section to a Process	765
22.5	Summary	768
	What You Should Have Learned	769
	References	769
	Short Answer Questions	769
	Problems	769
Chapter 23	Reactor Performance	785
	What You Will Learn	785
23.1	Production of Desired Product	786
23.2	Reaction Kinetics and Thermodynamics	788
	23.2.1 <i>Reaction Kinetics</i>	788
	23.2.2 <i>Thermodynamic Limitations</i>	790
23.3	The Chemical Reactor	791
23.4	Heat Transfer in the Chemical Reactor	796
23.5	Reactor System Case Studies	799
	23.5.1 <i>Replacement of Catalytic Reactor in Benzene Process</i>	800
	23.5.2 <i>Replacement of Cumene Catalyst</i>	804
	23.5.3 <i>Increasing Acetone Production</i>	809
23.6	Summary	812
	What You Should Have Learned	813
	References	813
	Short Answer Questions	813
	Problems	814
Chapter 24	Process Troubleshooting and Bottlenecking	819
	What You Will Learn	819
24.1	Recommended Methodology	821
	24.1.1 <i>Elements of Problem-Solving Strategies</i>	821
	24.1.2 <i>Application to Troubleshooting Problems</i>	823

- 24.2 Troubleshooting Individual Units 825
 - 24.2.1 *Troubleshooting a Packed-Bed Absorber* 825
 - 24.2.2 *Troubleshooting the Cumene Process Feed Section* 829
- 24.3 Troubleshooting Multiple Units 831
 - 24.3.1 *Troubleshooting Off-Specification Acrylic Acid Product* 831
 - 24.3.2 *Troubleshooting Steam Release in Cumene Reactor* 833
- 24.4 A Process Troubleshooting Problem 836
- 24.5 Debottlenecking Problems 840
- 24.6 Summary 841
 - What You Should Have Learned 841
 - References 841
 - Problems 841

SECTION V THE IMPACT OF CHEMICAL ENGINEERING DESIGN ON SOCIETY 853

Chapter 25 Ethics and Professionalism 855

- What You Will Learn 855
- 25.1 Ethics 856
 - 25.1.1 *Moral Autonomy* 857
 - 25.1.2 *Rehearsal* 857
 - 25.1.3 *Reflection in Action* 858
 - 25.1.4 *Mobile Truth* 859
 - 25.1.5 *Nonprofessional Responsibilities* 861
 - 25.1.6 *Duties and Obligations* 862
 - 25.1.7 *Codes of Ethics* 863
 - 25.1.8 *Whistle-Blowing* 865
 - 25.1.9 *Ethical Dilemmas* 870
 - 25.1.10 *Additional Ethics Heuristics* 870
 - 25.1.11 *Other Resources* 871
- 25.2 Professional Registration 874
 - 25.2.1 *Engineer-in-Training* 875
 - 25.2.2 *Registered Professional Engineer* 878
- 25.3 Legal Liability 879
- 25.4 Business Codes of Conduct 880
- 25.5 Summary 881
 - What You Should Have Learned 881
 - References 882
 - Problems 882

Chapter 26 Health, Safety, and the Environment 885

- What You Will Learn 885
- 26.1 Risk Assessment 886
 - 26.1.1 *Accident Statistics* 886
 - 26.1.2 *Worst-Case Scenarios* 887
 - 26.1.3 *The Role of the Chemical Engineer* 888
- 26.2 Regulations and Agencies 888
 - 26.2.1 *OSHA and NIOSH* 889

26.2.2	<i>Environmental Protection Agency (EPA)</i>	894
26.2.3	<i>Nongovernmental Organizations</i>	897
26.3	Fires and Explosions	898
26.3.1	<i>Terminology</i>	898
26.3.2	<i>Pressure-Relief Systems</i>	900
26.4	Process Hazard Analysis	900
26.4.1	<i>HAZOP</i>	901
26.4.2	<i>Dow Fire & Explosion Index and Chemical Exposure Index</i>	906
26.5	Chemical Safety and Hazard Investigation Board	909
26.6	Inherently Safe Design	909
26.7	Summary	910
26.8	Glossary	910
	What You Should Have Learned	912
	References	912
	Problems	913

Chapter 27 Green Engineering 915

	What You Will Learn	915
27.1	Environmental Regulations	915
27.2	Environmental Fate of Chemicals	916
27.3	Green Chemistry	919
27.4	Pollution Prevention during Process Design	920
27.5	Analysis of a PFD for Pollution Performance and Environmental Performance	922
27.6	An Example of the Economics of Pollution Prevention	923
27.7	Life Cycle Analysis	924
27.8	Summary	926
	What You Should Have Learned	926
	References	926
	Problems	927

SECTION VI INTERPERSONAL AND COMMUNICATION SKILLS 929

Chapter 28 Teamwork 931

	What You Will Learn	931
28.1	Groups	931
28.1.1	<i>Characteristics of Effective Groups</i>	932
28.1.2	<i>Assessing and Improving the Effectiveness of a Group</i>	935
28.1.3	<i>Organizational Behaviors and Strategies</i>	935
28.2	Group Evolution	940
28.2.1	<i>Forming</i>	940
28.2.2	<i>Storming</i>	941
28.2.3	<i>Norming</i>	941
28.2.4	<i>Performing</i>	943
28.3	Teams and Teamwork	943
28.3.1	<i>When Groups Become Teams</i>	943
28.3.2	<i>Unique Characteristics of Teams</i>	944
28.4	Misconceptions	945

28.4.1	<i>Team Exams</i>	946
28.4.2	<i>Overreliance on Team Members</i>	946
28.5	Learning in Teams	946
28.6	Other Reading	947
28.7	Summary	948
	What You Should Have Learned	949
	References	949
	Problems	949
Appendix A	Cost Equations and Curves for the CAPCOST Program	951
A.1	Purchased Equipment Costs	951
A.2	Pressure Factors	969
	<i>A.2.1 Pressure Factors for Process Vessels</i>	969
	<i>A.2.2 Pressure Factors for Other Process Equipment</i>	969
A.3	Material Factors and Bare Module Factors	973
	<i>A.3.1 Bare Module and Material Factors for Heat Exchangers, Process Vessels, and Pumps</i>	973
	<i>A.3.2 Bare Module and Material Factors for the Remaining Process Equipment</i>	977
	References	982
Index	983	

Material on the CD-ROM

Chapter 0 Outcomes Assessment

- 0.1 Student Self-Assessment
- 0.2 Assessment by Faculty
- 0.3 Summary
- References
- Other References

Chapter 29 Written and Oral Communication

What You Will Learn

- 29.1 Audience Analysis
- 29.2 Written Communication
 - 29.2.1 *Design Reports*
 - 29.2.2 *Transmittal Letters or Memos*
 - 29.2.3 *Executive Summaries and Abstracts*
 - 29.2.4 *Other Types of Written Communication*
 - 29.2.5 *Exhibits (Figures and Tables)*
 - 29.2.6 *References*
 - 29.2.7 *Strategies for Writing*
 - 29.2.8 *WVU Guidelines for Written Design Report*
- 29.3 Oral Communication
 - 29.3.1 *Formal Oral Presentations*
 - 29.3.2 *Briefings*
 - 29.3.3 *Visual Aids*
 - 29.3.4 *WVU Oral Presentation Guidelines*
- 29.4 Software and Author Responsibility
 - 29.4.1 *Spell Checkers*
 - 29.4.2 *Thesaurus*
 - 29.4.3 *Grammar Checkers*
 - 29.4.4 *Graphs*
 - 29.4.5 *Tables*
 - 29.4.6 *Colors and Exotic Features*
 - 29.4.7 *Raw Output from Process Simulators*

- 29.5 **Summary**
 - What You Should Have Learned
 - References
 - Problems

Chapter 30 A Report-Writing Case Study

- 30.1 **The Assignment Memorandum**
- 30.2 **Response Memorandum**
- 30.3 **Visual Aids**
- 30.4 **Example Reports**
 - 30.4.1 *An Example of a Portion of a Student Written Report*
 - 30.4.2 *An Example of an Improved Student Written Report*
- 30.5 **Checklist of Common Mistakes and Errors**
 - 30.5.1 *Common Mistakes for Visual Aids*
 - 30.5.2 *Common Mistakes for Written Text*

Appendix B Information for the Preliminary Design of Fifteen Chemical Processes

- B.1 **Dimethyl Ether (DME) Production, Unit 200**
 - B.1.1 *Process Description*
 - B.1.2 *Reaction Kinetics*
 - B.1.3 *Simulation (CHEMCAD) Hints*
 - B.1.4 *References*
- B.2 **Ethylbenzene Production, Unit 300**
 - B.2.1 *Process Description*
 - B.2.2 *Reaction Kinetics*
 - B.2.3 *Simulation (CHEMCAD) Hints*
 - B.2.4 *References*
- B.3 **Styrene Production, Unit 400**
 - B.3.1 *Process Description*
 - B.3.2 *Reaction Kinetics*
 - B.3.3 *Simulation (CHEMCAD) Hints*
 - B.3.4 *References*
- B.4 **Drying Oil Production, Unit 500**
 - B.4.1 *Process Description*
 - B.4.2 *Reaction Kinetics*
 - B.4.3 *Simulation (CHEMCAD) Hints*
 - B.4.4 *Reference*
- B.5 **Production of Maleic Anhydride from Benzene, Unit 600**
 - B.5.1 *Process Description*
 - B.5.2 *Reaction Kinetics*
 - B.5.3 *Simulation (CHEMCAD) Hints*
 - B.5.4 *References*
- B.6 **Ethylene Oxide Production, Unit 700**
 - B.6.1 *Process Description*
 - B.6.2 *Reaction Kinetics*
 - B.6.3 *Simulation (CHEMCAD) Hints*
 - B.6.4 *References*

- B.7 Formalin Production, Unit 800**
 - B.7.1 Process Description*
 - B.7.2 Reaction Kinetics*
 - B.7.3 Simulation (CHEMCAD) Hints*
 - B.7.4 References*
- B.8 Batch Production of L-Phenylalanine and L-Aspartic Acid, Unit 900**
 - B.8.1 Process Description*
 - B.8.2 Reaction Kinetics*
 - B.8.3 References*
- B.9 Acrylic Acid Production via the Catalytic Partial Oxidation of Propylene, Unit 1000**
 - B.9.1 Process Description*
 - B.9.2 Reaction Kinetics and Reactor Configuration*
 - B.9.3 Simulation (CHEMCAD) Hints*
 - B.9.4 References*
- B.10 Production of Acetone via the Dehydrogenation of Isopropyl Alcohol (IPA), Unit 1100**
 - B.10.1 Process Description*
 - B.10.2 Reaction Kinetics*
 - B.10.3 Simulation (CHEMCAD) Hints*
 - B.10.4 References*
- B.11 Production of Heptenes from Propylene and Butenes, Unit 1200**
 - B.11.1 Process Description*
 - B.11.2 Reaction Kinetics*
 - B.11.3 Simulation (CHEMCAD) Hints*
 - B.11.4 Reference*
- B.12 Design of a Shift Reactor Unit to Convert CO to CO₂, Unit 1300**
 - B.12.1 Process Description*
 - B.12.2 Reaction Kinetics*
 - B.12.3 Simulation (Aspen Plus) Hints*
 - B.12.4 Reference*
- B.13 Design of a Dual-Stage Selexol Unit to Remove CO₂ and H₂S from Coal-Derived Synthesis Gas, Unit 1400**
 - B.13.1 Process Description*
 - B.13.2 Simulation (Aspen Plus) Hints*
 - B.13.3 References*
- B.14 Design of a Claus Unit for the Conversion of H₂S to Elemental Sulfur, Unit 1500**
 - B.14.1 Process Description*
 - B.14.2 Reaction Kinetics*
 - B.14.3 Simulation (Aspen Plus) Hints*
 - B.14.4 References*
- B.15 Modeling a Downward-Flow, Oxygen-Blown, Entrained-Flow Gasifier, Unit 1600**
 - B.15.1 Process Description*
 - B.15.2 Reaction Kinetics*
 - B.15.3 Simulation (Aspen Plus) Hints*
 - B.15.4 References*

Appendix C Design Projects**Project 1 Increasing the Production of 3-Chloro-1-Propene (Allyl Chloride) in Unit 600**

- C.1.1 Background
- C.1.2 Process Description of the Beaumont Allyl Chloride Facility
- C.1.3 Specific Objectives of Assignment
- C.1.4 Additional Background Information
- C.1.5 Process Design Calculations
- C.1.6 Reference

Project 2 Design and Optimization of a New 20,000-Metric-Tons-per-Year Facility to Produce Allyl Chloride at La Nueva Cantina, Mexico

- C.2.1 Background
- C.2.2 Assignment
- C.2.3 Problem-Solving Methodology
- C.2.4 Process Information

Project 3 Scale-Down of Phthalic Anhydride Production at TBWS Unit 700

- C.3.1 Background
- C.3.2 Phthalic Anhydride Production
- C.3.3 Other Information
- C.3.4 Assignment
- C.3.5 Report Format

Project 4 The Design of a New 100,000-Metric-Tons-per-Year Phthalic Anhydride Production Facility

- C.4.1 Background
- C.4.2 Other Information
- C.4.3 Assignment
- C.4.4 Report Format

Project 5 Problems at the Cumene Production Facility, Unit 800

- C.5.1 Background
- C.5.2 Cumene Production Reactions
- C.5.3 Process Description
- C.5.4 Recent Problems in Unit 800
- C.5.5 Other Information
- C.5.6 Assignment
- C.5.7 Report Format
- C.5.8 Process Calculations

Project 6 Design of a New 100,000-Metric-Tons-per-Year Cumene Production Facility

- C.6.1 Background
- C.6.2 Assignment
- C.6.3 Report Format

Preface

This book represents the culmination of many years of teaching experience in the senior design course at West Virginia University (WVU) and University of Nevada, Reno. Although the program at WVU has evolved over the past 35 years and is still evolving, it is fair to say that the current program has gelled over the past 25 years as a concerted effort by the authors to integrate design throughout the undergraduate curriculum in chemical engineering.

We view design as the focal point of chemical engineering practice. Far more than the development of a set of specifications for a new chemical plant, design is the creative activity through which engineers continuously improve the operations of facilities to create products that enhance the quality of life. Whether developing the grassroots plant, proposing and guiding process modifications, or troubleshooting and implementing operational strategies for existing equipment, engineering design requires a broad spectrum of knowledge and intellectual skills to be able to analyze the big picture and the minute details and, most important, to know when to concentrate on each.

Our vehicle for helping students develop and hone their design skills is process design rather than plant design, covering synthesis of the entire chemical process through topics relating to the preliminary sizing of equipment, flowsheet optimization, economic evaluation of projects, and the operation of chemical processes. The purpose of this text is to assist chemical engineering students in making the transition from solving well-posed problems in a specific subject to integrating all the knowledge that they have gained in their undergraduate education and applying this information to solving open-ended process problems. Many of the nuts-and-bolts issues regarding plant design (for example, what schedule pipe to use for a given stream or what corrosion allowance to use for a vessel in a certain service) are not covered. Although such issues are clearly important to the practicing engineer, several excellent handbooks and textbooks are available to address such problems, and these are cited in the text where applicable.

In the fourth edition, we have rearranged some of the material from previous editions, and we have added two new chapters on advanced concepts in steady-state simulation (Chapter 16) and dynamic simulation of processes (Chapter 17). We have also added extensive material on the choice of thermodynamics package to use for modeling processes containing electrolyte solutions and solids (Chapter 13) and a brief introduction to logic control (Chapter 18). Additional pedagogical material has been added to each chapter to outline the key concepts and major lessons to be learned from each chapter.

We continue to emphasize the importance of understanding, analyzing, and synthesizing chemical processes and process flow diagrams. To this end, we have expanded Appendix B to include an additional four (making a total of 15) preliminary designs of chemical processes. All the projects have been moved to the CD accompanying the text, along with the chapters on outcomes assessment, written and oral communications, and a written report case study and the projects from Appendix C of the first edition.

The arrangement of chapters into the six sections of the book is similar to that adopted in the second edition. These sections are as follows:

- Section I—Conceptualization and Analysis of Chemical Processes
- Section II—Engineering Economic Analysis of Chemical Processes
- Section III—Synthesis and Optimization of Chemical Processes
- Section IV—Analysis of Process Performance
- Section V—The Impact of Chemical Engineering Design on Society
- Section VI—Interpersonal and Communication Skills

In Section I, the student is introduced first to the principal diagrams that are used to describe a chemical process. Next, the evolution and generation of different process configurations are covered. Key concepts used in evaluating batch processes are included in Chapter 3, and the concepts of product design are given in Chapter 4. Finally, the analysis of existing processes is covered. In Section II, the information needed to assess the economic feasibility of a process is covered. This includes the estimation of fixed capital investment and manufacturing costs, the concepts of the time value of money and financial calculations, and finally the combination of these costs into profitability measures for the process. Section III covers the synthesis of a chemical process. The minimum information required to simulate a process is given, as are the basics of using a process simulator. The choice of the appropriate thermodynamic model to use in a simulation is covered, and the choice of separation operations is covered. Process optimization (including an introduction to optimization of batch processes) and heat integration techniques are covered in this section. In addition, new material on advanced concepts using steady-state process simulators (Chapter 16) and the use of dynamic simulators (Chapter 17) has been added, and the chapter on process regulation has been expanded and rounds out Section III. In Section IV, the analysis of the performance of existing processes and equipment is covered. The material in Section 4 is substantially different from that found in most textbooks. We consider equipment that is already built and operating and analyze how the operation can be changed, how an operating problem may be solved, and how to analyze what has occurred in the process to cause an observed change. In Section V, the impact of chemical engineering design on society is covered. The role of the professional engineer in society is addressed. Separate chapters addressing ethics and professionalism, health, safety, and the environment, and green engineering are included. Finally, in Section VI, the interpersonal skills required by the engineer to function as part of a team and to communicate both orally and in written form are covered (on the CD). An entire chapter (on the CD) is devoted to addressing some of the common mistakes that students make in written reports.

Finally, three appendices are included. Appendix A gives a series of cost charts for equipment. This information is embedded in the CAPCOST program for evaluating fixed capital investments and process economics. Appendix B gives the preliminary design

information for 15 chemical processes: dimethyl ether, ethylbenzene, styrene, drying oil, maleic anhydride, ethylene oxide, formalin, batch manufacture of amino acids, acrylic acid, acetone, heptenes production, shift reaction, acid-gas removal by a physical solvent, the removal of H_2S from a gas stream using the Claus process, and finally coal gasification. Appendix B is now located on the CD accompanying the book. This information is used in many of the end-of-chapter problems in the book. These processes can also be used as the starting point for more detailed analyses—for example, optimization studies. Other projects, given in Appendix C, are also included on the CD book. The reader (faculty and students) is also referred to our Web site at www.che.cemr.wvu.edu/publications/projects/, where a variety of design projects for sophomore- through senior-level chemical engineering courses is provided. There is also a link to another Web site that contains environmentally related design projects.

For a one-semester design course, we recommend including the following core:

- Section I—Chapters 1 through 6
- Section III—Chapters 11, 12, and 13
- Section V—Chapters 25 and 26

For programs in which engineering economics is not a prerequisite to the design course, Section II (Chapters 7–10) should also be included. If students have previously covered engineering economics, Chapters 14 and 15 covering optimization and pinch technology could be substituted.

For the second term of a two-term sequence, we recommend Chapters 19 through 23 (and Chapters 14 and 15 if not included in the first design course) plus a design project. Alternatively, advanced simulation techniques in Chapters 16 and 17 could be covered. If time permits, we also recommend Chapter 18 (Regulation and Control of Chemical Processes with Applications Using Commercial Software) and Chapter 24 (Process Troubleshooting and Debottlenecking) because these tend to solidify as well as extend the concepts of Chapters 19 through 23, that is, what an entry-level process engineer will encounter in the first few years of employment at a chemical process facility. For an environmental emphasis, Chapter 27 could be substituted for Chapters 18 and 24; however, it is recommended that supplementary material be included.

We have found that the most effective way both to enhance and to examine student progress is through oral presentations in addition to the submission of written reports. During these oral presentations, individual students or a student group defends its results to a faculty panel, much as a graduate student defends a thesis or dissertation.

Because design is at its essence a creative, dynamic, challenging, and iterative activity, we welcome feedback on and encourage experimentation with this design textbook. We hope that students and faculty will find the excitement in teaching and learning engineering design that has sustained us over the years.

Finally, we would like to thank those people who have been instrumental to the successful completion of this book. Many thanks are given to all undergraduate chemical engineering students at West Virginia University over the years, particularly the period 1992–2011. In particular, we would like to thank Joe Stoffa, who was responsible for developing the spreadsheet version of CAPCOST, and Mary Metzger and John Ramsey, who were responsible for collecting and correlating equipment cost information for this edition. We also acknowledge the many colleagues who have provided, both formally and

informally, feedback about this text. Finally, RT would like to thank his wife, Becky; JAS would like to thank his wife, Terry; and DB would like to thank his parents, Sambhunath and Gayatri, wife Pampa, and son Swagat for their continued support, love, and patience during the preparation of this fourth edition.

R.T.
R.C.B.
W.B.W.
J.A.S.
D.B.

About the Authors

Richard Turton, P.E., has taught the senior design course at West Virginia University for the past 26 years. Prior to this, he spent five years in the design and construction industry. His main interests are in design education, particulate processing, and process modeling.

Richard C. Bailie has more than ten years of experience in process evaluation, pilot plant operation, plant start-up, and industrial consulting. He also ran his own chemical company. He is professor emeritus at WVU, having taught chemical engineering for more than 20 years.

Wallace B. Whiting, P.E., is professor emeritus at University of Nevada, Reno. He has been involved in the practice and teaching of chemical process design for more than 24 years.

Joseph A. Shaeiwitz taught design and design-related classes at WVU for more than 25 years. He now teaches design at Auburn University. His interests include design education, and outcomes assessment.

Debangsu Bhattacharyya has more than ten years' work experience in a large petroleum refinery. While in the refinery, he worked in process operations, plant start-up, large-scale process simulation, and process control. His main research interests are in process modeling, dynamic simulation, state estimation, sensor placement, and advanced process control.

This page intentionally left blank

List of Nomenclature

Symbol	Definition	SI Units
A	Equipment Cost Attribute	
A	Area	m^2
A	Absorption Factor	
A	Annuity Value	\$/time
$A/F, i, n$	Sinking Fund Factor	
$A/P, i, n$	Capital Recovery Factor	
A_b	Bubbling Area	m^2
A_c	Cross-Sectional Area	m^2
a	Interfacial Area	m^2
a	Mean Ionic Diameter of an Electrolyte	m
a'	Interface Area per Unit Volume	m^2/m^3
BV	Book Value	\$
C	Molar Density	mol/m^3
C	Equipment Cost	\$
C or c	Molar Concentration	$kmol/m^3$
CA	Corrosion Allowance	m
CBM	Bare Module Cost	\$
COM	Cost of Manufacture	\$/time
cop	Coefficient of Performance	
C_p	Heat Capacity	$kJ/kg^\circ C$ or $kJ/kmol^\circ C$
CCP	Cumulative Cash Position	\$
CCR	Cumulative Cash Ratio	
D	Diffusivity	m^2/s
D	Diameter	m
D	Amount Allowed for Depreciation	\$
D	Distillate Product Flowrate	$kmol/time$
d	Yearly Depreciation Allowance	\$/yr
$DCFROR$	Discounted Cash Flow Rate of Return	
DMC	Direct Manufacturing Cost	\$/time
$DPBP$	Discounted Payback Period	years
\bar{D}	Average Diffusivity	m^2/s
D_0	Diffusivity at Infinite Dilution	m^2/s
d	Vector of Disturbance Inputs	

d_s	Average Solvent Density	kg/m ³
e	Elementary Charge	Columb
E	Money Earned	\$
E	Weld Efficiency	
E_{act} or E	Activation Energy	kJ/kmol
EAOC	Equivalent Annual Operating Cost	\$/yr
ECC	Equivalent Capitalized Cost	\$
F	Faraday's Constant	Columb/kmol
f_q	Quantity Factors for Trays	
F	Future Value	\$
F	Molar Flowrate	kmol/s
F	Equipment Module Cost Factor	
F	Correction for Multipass Heat Exchangers	
F	Future Value	\$
F_d	Drag Force	N/m ² or kPa
f	Friction Factor	
f	Rate of Inflation	
$F/A, i, n$	Uniform Series Compound Amount Factor	
FCI	Fixed Capital Investment	\$
$F/P, i, n$	Single Payment Compound Amount Factor	
FMC	Fixed Manufacturing Costs	\$/time
F_{Lang}	Lang Factor	
f_i	Fugacity of Pure Component i	bar or kPa
\hat{f}_i	Fugacity of Component i in Mixture	bar or kPa
f	System of Equations (vector)	
G	Gibbs Free Energy	kJ
G	Gas Flowrate	kg/s, kmol/s
GE	General Expenses	\$/time
H	Henry's Law Constant	bar or kPa in Equation (13.5), but can be different elsewhere
h	Individual Heat Transfer Coefficient	W/m ² K
H	Enthalpy or Specific Enthalpy	kJ or kJ/kg
H	Height	m
h_f	Froth Height in a Tray	m
I	Identity Matrix	
I	Ionic Concentration	kmol/m ³
I_x	Ionic Strength on a Mole Fraction Basis	
I	Cost Index	
i	Compound Interest	
i'	Effective Interest Rate Including Inflation	
INPV	Incremental Net Present Value	\$
IPBP	Incremental Payback Period	years
J	Jacobian Matrix	

k	Thermal Conductivity	W/m K
k_o	Preexponential Factor for Reaction Rate Constant	Depends on molecularity of reaction
K_p	Equilibrium Constant	Depends on reaction stoichiometry
k_{reac} or k_i	Reaction Rate Constant	Depends on molecularity of reaction
K_c	Proportional Gain	
K_{cu}	Ultimate Controller Gain	
K_{eq}	Equilibrium Constant of a Chemical Reaction	
K_i	Vapor-Liquid Equilibrium Ratio of Species i	
k_B	Boltzmann Constant	kJ/K
k_m	Average Mass Transfer Coefficient	m/s
L	Lean Stream Flowrate	kg/s
L	Liquid Flowrate	kg/s or kmol/s
\dot{m}	Flowrate	kg/s
m	Partition Coefficient (y/x)	
M	Mass	kg
m	Molality	kmol/kg
n	Life of Equipment	years
n	Years of Investment	years
n	Number of Batches	
n_c	Number of Campaigns	
N	Number of Streams	
N	Number of Trays, Stages, or Shells	
N	Molar Flowrate	kmol/s
$NPSH$	Net Positive Suction Head	m of liquid
NPV	Net Present Value	\$
N_{toG}	Number of Transfer Units	
N	Molar Hold-up	kmol
OBJ, OF	Objective Function	usually \$ or \$/time
p	Price	\$
P	Dimensionless Temperature Approach	
P	Pressure	bar or kPa
P	Present Value	\$
P^*	Vapor Pressure	bar or kPa
$P/A, i, n$	Uniform Series Present Worth Factor	
PBP	Payback Period	year
PC	Project Cost	\$
$P/E, i, n$	Single Payment Present Worth Factor	
PVR	Present Value Ratio	
$P(x)$	Probability Density Function of x	
P_u	Ultimate Period of Oscillation	s
Q or q	Rate of Heat Transfer	W or MJ/h
Q	Quantity	
\dot{Q}	Heat Transfer Rate	W or MJ/h
r	Radius	m

r	Reaction Rate	kmol/m ³ or kmol/kg cat s
r	Rate of Production	kg/h
R	Gas Constant	kJ/kmol K
R	Ratio of Heat Capabilities	
R	Residual Funds Needed	\$
R	Reflux Ratio	
Re	Reynolds Number	
R	Rich Stream Flowrate	kg/s
$Rand$	Random Number	
$ROROI$	Rate of Return on Investment	
$ROROI$	Rate of Return on Incremental Investment	
S	Entropy	kJ/K
S	Salvage Value	\$
S	Maximum Allowable Working Pressure	bar
S	Salt Concentration Factor	
S	Sensitivity	
SF	Stream Factor	
T_m	Melting Temperature	K
t	Thickness of Wall	m
t	Time	s, min, h, yr
T	Total Time for a Batch	s, min, h, yr
T	Temperature	K, R, °C, or °F
U	Internal Energy	kJ
u	Vector of Manipulated Inputs	
u	Flow Velocity	m/s
U	Overall Heat Transfer Coefficient	W/m ² K
v	Molar Volume	m ³ /mol
V	Volume	m ³
V	Vapor Flow Rate	kmol/h
v_{react}	Specific Volume of Reactor	m ³ /kg of product
v_p	Velocity	m/s
\dot{v}	Volumetric Flowrate	m ³ /s
W	Weight	kg
W	Total Moles of a Component	kmol
W or WS	Work	kJ/kg
WC	Working Capital	\$
X	Matrix of Independent Variables	
x	Vector of Variables	
X	Conversion	
X	Base-Case Ratio	
x	Mole or Mass Fraction	
y	Mole or Mass Fraction	
YOC	Yearly Operating Cost	\$/yr
YS	Yearly Cash Flow (Savings)	\$/yr
z	Valence of Ions	
z	Solids Mole Fraction	
z	Distance	m

Greek Symbols

α	Multiplication Cost Factor	
α	Relative Volatility	
α	NRTL Non-randomness Factor	
δ	Thickness of the Ion-Free Layer below	
ε	Void Fraction	
ε	Pump Efficiency	
ε	Tolerance, Error	
ε_{ij}	Lennard-Jones Energy Parameter between Species i and j	kJ/kmol
ε_r	Relative Permittivity of the Solvent	
ε_r'	Relative Permittivity of the Vapor Phase	
ε_s	Permittivity of the Solvent	Columb ² /kJ m
ϕ	Fugacity Coefficient	
$\hat{\phi}$	Fugacity Coefficient in Mixture	
ϕ^*	Fugacity Coefficient of Saturated Vapor	
γ	Activity Coefficient	
γ^∞	Activity Coefficient in the Mixture at Infinite Dilution	
γ_\pm	Mean Ionic Activity Coefficient	
κ	Inverse of Debye-Hückel length	1/m
η	Selectivity	
λ	Heat of Vaporization	kJ/kg
λ	Eigenvalue	
λ	Heat of Vaporization/Condensation	kJ/kg
λ	Lagrangian Multiplier Vector	
λ_0	Thermal Conductivity of Pure Solvent	W/–m K
μ	Viscosity	kg/m s
μ_c	Chemical Potential	kJ
μ_0	Viscosity of Pure Solvent	kg/m s
θ	Parameter Vector	
θ	Rates of Species Concentration to that of Limiting Reactant	s\
σ	Statistical Variance	
σ	Collision Diameter	m
σ	Surface Tension	N/m
ξ	Selectivity	
ρ	Density	kg/m ³
Θ	Cycle Time	s
τ	Space Time	s
τ	NRTL Binary Interaction Energy Parameter	
τ_D	Derivative Time Constant	s
τ_I	Integral Time	s
Ω	Collision Integral	

Subscripts

1	Base Time
2	Desired Time

<i>a</i>	Required Attribute
<i>ACT</i>	Actual
<i>Aux</i>	Auxiliary Buildings
<i>a, a'</i>	Anion
<i>b</i>	Base Attribute
<i>BM</i>	Bare Module
<i>c, c'</i>	Cation
<i>c</i>	Cold
<i>clean</i>	Cleaning
<i>Cont</i>	Contingency
<i>cycle</i>	Cycle
<i>d</i>	Without Depreciation
<i>D, d</i>	Demand
<i>E</i>	Contractor Engineering Expenses
<i>eff</i>	Effective Interest
<i>eq</i>	Equivalent
<i>el</i>	Electrolyte(s)
<i>eq</i>	Metal in the Equipment
<i>Fee</i>	Contractor Fee
<i>FTT</i>	Transportation, etc.
<i>GR</i>	Grass Roots
<i>h</i>	Hot
<i>i</i>	Species
<i>i</i>	Index
<i>in</i>	Inlet
<i>k</i>	Year
<i>L</i>	Installation Labor
<i>L</i>	Lean Streams
<i>L</i>	Without Land Cost
<i>LF</i>	Long-Range Force
<i>m</i>	Molality Scale
<i>m</i>	Molecular Species
<i>m</i>	Heating/Cooling Medium
<i>m</i>	Number of Years
<i>M</i>	Materials for Installation
<i>M</i>	Material Cost Factor
<i>max</i>	Maximum
<i>MC</i>	Matching Costs
<i>min</i>	Minimum
<i>n</i>	Index for Time Instant
<i>nom</i>	Nominal Interest
<i>out</i>	Outlet
<i>O or OH</i>	Construction Overhead
<i>Off</i>	Offsites and Utilities
<i>OL</i>	Operating Labor
<i>opt</i>	Optimum
<i>p</i>	Production
<i>P</i>	Equipment at Manufacturer's Site (Purchased)
<i>P</i>	Pressure Cost Factor

P&I	Piping and Instrumentation
<i>R</i>	Rich Stream
<i>RM</i>	Raw Materials
rev	Reversible
<i>rxn, r</i>	Reaction
<i>s</i>	All Non-Water Solvents
<i>s</i>	Simple Interest
S	Supply
<i>Site</i>	Site Development
<i>SF</i>	Short-Range Force
<i>TM</i>	Total Module
<i>UT</i>	Utilities
<i>WT</i>	Waste Treatment
<i>w</i>	Water
+	Cation
-	Anion

Superscripts

<i>DB</i>	Double Declining Balance Depreciation
<i>E or ex</i>	Excess Property
<i>L</i>	Lower Limit
<i>l</i>	Liquid
<i>o</i>	Cost for Ambient Pressure Using Carbon Steel
<i>s</i>	Solid
<i>SL</i>	Straight Line Depreciation
<i>SOYD</i>	Sum of the Years Depreciation
<i>U</i>	Upper Limit
<i>v</i>	Vapor
∞	Aqueous Infinite Dilution
'	Includes Effect of Inflation on Interest

Additional Nomenclature

Table 1.2	Convention for Specifying Process Equipment
Table 1.3	Convention for Specifying Process Streams
Table 1.7	Abbreviations for Equipment and Materials of Construction
Table 1.10	Convention for Specifying Instrumentation and Control Systems

Note: In this book, matrices are denoted by boldface, uppercase, italicized letters and vectors are denoted by boldface, lowercase, italicized letters.

This page intentionally left blank

Diagrams for Understanding Chemical Processes

WHAT YOU WILL LEARN

- Different types of chemical process diagrams
- How these diagrams represent different scales of process views
- One consistent method for drawing process flow diagrams
- The information to be included in a process flow diagram
- The purpose of operator training simulators and recent advances in 3-D representation of different chemical processes

The chemical process industry (CPI) is involved in the production of a wide variety of products that improve the quality of our lives and generate income for companies and their stockholders. In general, chemical processes are complex, and chemical engineers in industry encounter a variety of chemical process flow diagrams. These processes often involve substances of high chemical reactivity, high toxicity, and high corrosivity operating at high pressures and temperatures. These characteristics can lead to a variety of potentially serious consequences, including explosions, environmental damage, and threats to people's health. It is essential that errors or omissions resulting from missed communication between persons and/or groups involved in the design and operation do not occur when dealing with chemical processes. Visual information is the clearest way to present material and is least likely to be misinterpreted. For these reasons, it is essential that chemical engineers be able to formulate appropriate process diagrams and be skilled in analyzing and interpreting diagrams prepared by others.

The most effective way of communicating information about a process is through the use of flow diagrams.

This chapter presents and discusses the more common flow diagrams encountered in the chemical process industry. These diagrams evolve from the time a process is conceived in the laboratory through the design, construction, and the many years of plant operation. The most important of these diagrams are described and discussed in this chapter.

The following narrative is taken from Kauffman [1] and describes a representative case history related to the development of a new chemical process. It shows how teams of engineers work together to provide a plant design and introduces the types of diagrams that will be explored in this chapter.

*The research and development group at ABC Chemicals Company worked out a way to produce alpha-beta souptol (ABS). Process engineers assigned to work with the development group have pieced together a continuous process for making ABS in commercial quantities and have tested key parts of it. This work involved hundreds of **block flow diagrams**, some more complex than others. Based on information derived from these block flow diagrams, a decision was made to proceed with this process.*

*A process engineering team from ABC's central office carries out the detailed process calculations, material and energy balances, equipment sizing, etc. Working with their drafting department, they produced a series of **PFDs (Process Flow Diagrams)** for the process. As problems arise and are solved, the team may revise and redraw the PFDs. Often the work requires several rounds of drawing, checking, and revising.*

Specialists in distillation, process control, kinetics, and heat transfer are brought in to help the process team in key areas. Some are company employees and others are consultants.

*Since ABC is only a moderate-sized company, it does not have sufficient staff to prepare the 120 **P&IDs (Piping and Instrumentation Diagrams)** needed for the new ABS plant. ABC hires a well-known engineering and construction firm (**E&C Company**), DEFCo, to do this work for them. The company assigns two of the ABC process teams to work at DEFCo to coordinate the job. DEFCo's process engineers, specialists, and drafting department prepare the P&IDs. They do much of the detailed engineering (pipe sizes, valve specifications, etc.) as well as the actual drawing. The job may take two to six months. Every drawing is reviewed by DEFCo's project team and by ABC's team. If there are disagreements, the engineers and specialists from the companies must resolve them.*

Finally, all the PFDs and the P&IDs are completed and approved. ABC can now go ahead with the construction. They may extend their contract with DEFCo to include this phase, or they may go out for construction bids from a number of sources.

This narrative describes a typical sequence of events taking a project from its initial stages through plant construction. If DEFCo had carried out the construction, ABC could go ahead and take over the plant or DEFCo could be contracted to carry out the start-up and to commission the plant. Once satisfactory performance specifications have been met, ABC would take over the operation of the plant and commercial production would begin.

From conception of the process to the time the plant starts up, two or more years will have elapsed and millions of dollars will have been spent with no revenue from the plant. The plant must operate successfully for many years to produce sufficient income to pay for all plant operations and to repay the costs associated with designing and building the plant. During this operating period, many unforeseen changes are likely to take place. The quality of the raw materials used by the plant may change, product specifications may be raised, production rates may need to be increased, the equipment performance will decrease because of wear, the development of new and better catalysts will occur, the costs of utilities will change, new environmental regulations may be introduced, or improved equipment may appear on the market.

As a result of these unplanned changes, plant operations must be modified. Although the operating information on the original process diagrams remains informative, the actual performance taken from the operating plant will be different. The current operating conditions will appear on updated versions of the various process diagrams, which will act as a primary basis for understanding the changes taking place in the plant. These process diagrams are essential to an engineer who has been asked to diagnose operating problems, solve problems in operations, debottleneck systems for increased capacity, and predict the effects of making changes in operating conditions. All these activities are essential in order to maintain profitable plant operation.

In this chapter, the focus is on three diagrams that are important to chemical engineers: block flow, process flow, and piping and instrumentation diagrams. Of these three diagrams, the most useful to chemical engineers is the PFD. The understanding of the PFD represents a central goal of this textbook.

1.1 BLOCK FLOW DIAGRAM (BFD)

Block flow diagrams were introduced early in the chemical engineering curriculum. In the first course in material and energy balances, often an initial step was to convert a word problem into a simple block diagram. This diagram consisted of a series of blocks representing different equipment or unit operations that were connected by input and output streams. Important information such as operating temperatures, pressures, conversions, and yield was included on the diagram along with flowrates and some chemical compositions. However, the diagram did not include any details of equipment within any of the blocks.

The block flow diagram can take one of two forms. First, a block flow diagram may be drawn for a single process. Alternatively, a block flow diagram may be drawn for a complete chemical complex involving many different chemical processes. These two types of diagrams are differentiated by calling the first a block flow process diagram and the second a block flow plant diagram.

1.1.1 Block Flow Process Diagram

An example of a block flow process diagram is shown in Figure 1.1, and the process illustrated is described below.

Toluene and hydrogen are converted in a reactor to produce benzene and methane. The reaction does not go to completion, and excess toluene is required. The noncondensable gases are separated and discharged. The benzene product and the unreacted toluene are then separated by distillation. The toluene is then recycled back to the reactor and the benzene removed in the product stream.

This block flow diagram gives a clear overview of the production of benzene, unobstructed by the many details related to the process. Each block in the diagram represents a process function and may, in reality, consist of several pieces of equipment. The general format and conventions used in preparing block flow process diagrams are presented in Table 1.1.

Although much information is missing from Figure 1.1, it is clear that such a diagram is very useful for “getting a feel” for the process. Block flow process diagrams often form the starting point for developing a PFD. They are also very helpful in conceptualizing new processes and explaining the main features of the process without getting bogged down in the details.

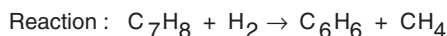
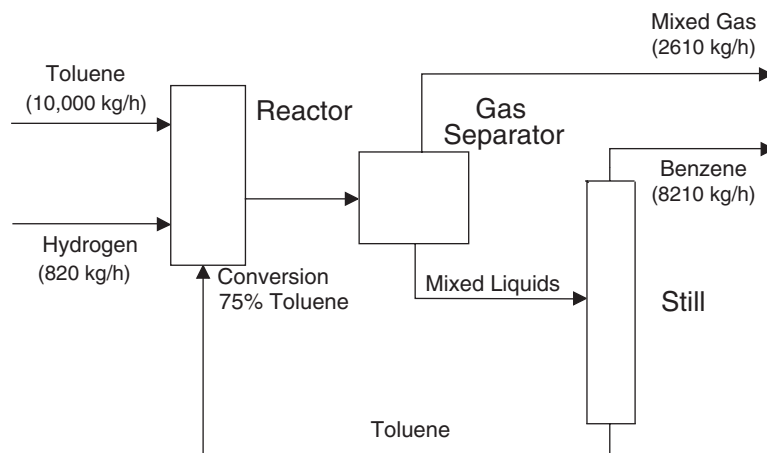

Figure 1.1 Block Flow Process Diagram for the Production of Benzene

1.1.2 Block Flow Plant Diagram

An example of a block flow plant diagram for a complete chemical complex is illustrated in Figure 1.2. This block flow plant diagram is for a coal to higher alcohol fuels plant. Clearly, this is a complicated process in which there are a number of alcohol fuel products produced from a feedstock of coal. Each block in this diagram represents a complete chemical process (compressors and turbines are also shown as trapezoids), and a block flow process diagram could be drawn for each block in Figure 1.2. The advantage of a diagram such as Figure 1.2 is that it allows a complete picture of what this plant does and how all the different processes interact to be obtained. On the other hand, in order to keep the diagram relatively uncluttered, only limited information is available about each process unit. The conventions for drawing block flow plant diagrams are similar to Table 1.1.

Both types of block flow diagrams are useful for explaining the overall operation of chemical plants. For example, consider that you have just joined a large chemical manufacturing company that produces a wide range of chemical products from the site to which you have been assigned. You would most likely be given a *block flow plant diagram*

Table 1.1 Conventions and Format Recommended for Laying Out a Block Flow Process Diagram

1. Operations shown by blocks.
2. Major flow lines shown with arrows giving direction of flow.
3. Flow goes from left to right whenever possible.
4. Light stream (gases) toward top with heavy stream (liquids and solids) toward bottom.
5. Critical information unique to process supplied.
6. If lines cross, then the horizontal line is continuous and the vertical line is broken (hierarchy for all drawings in this book).
7. Simplified material balance provided.

to orient you to the products and important areas of operation. Once assigned to one of these areas, you would again likely be provided with a *block flow process diagram* describing the operations in your particular area.

In addition to the orientation function described earlier, block flow diagrams are used to sketch out and screen potential process alternatives. Thus, they are used to convey information necessary to make early comparisons and eliminate competing alternatives without having to make detailed and costly comparisons.

1.2 PROCESS FLOW DIAGRAM (PFD)

The process flow diagram (PFD) represents a quantum step up from the BFD in terms of the amount of information that it contains. The PFD contains the bulk of the chemical engineering data necessary for the design of a chemical process. For all of the diagrams discussed in this chapter, there are no universally accepted standards. The PFD from one company will probably contain slightly different information from the PFD for the same process from another company. Having made this point, it is fair to say that most PFDs convey very similar information. A typical commercial PFD will contain the following information:

1. All the major pieces of equipment in the process will be represented on the diagram along with a description of the equipment. Each piece of equipment will have assigned a unique equipment number and a descriptive name.
2. All process flow streams will be shown and identified by a number. A description of the process conditions and chemical composition of each stream will be included. These data will be either displayed directly on the PFD or included in an accompanying flow summary table.
3. All utility streams supplied to major equipment that provides a process function will be shown.
4. Basic control loops, illustrating the control strategy used to operate the process during normal operations, will be shown.

It is clear that the PFD is a complex diagram requiring a substantial effort to prepare. It is essential that it should remain uncluttered and be easy to follow, to avoid errors in presentation and interpretation. Often PFDs are drawn on large sheets of paper (for example, size D: 24 in \times 36 in), and several connected sheets may be required for a complex process. Because of the page size limitations associated with this text, complete PFDs cannot be presented here. Consequently, certain liberties have been taken in the presentation of the PFDs in this text. Specifically, certain information will be presented in accompanying tables, and only the essential process information will be included on the PFD. The resulting PFDs will retain clarity of presentation, but the reader must refer to the flow summary and equipment summary tables in order to extract all the required information about the process.

Before the various aspects of the PFD are discussed, it should be noted that the PFD and the process that is described in this chapter will be used throughout the book. The process is the hydrodealkylation of toluene to produce benzene. This is a well-studied and well-understood commercial process still used today. The PFD presented in this chapter for this process is technically feasible but is in no way optimized. In fact, many improvements to the process technology and economic performance can be made. Many of these improvements will become evident when the appropriate material is presented. This allows the techniques provided throughout this text to be applied both to identify technical and

economic problems in the process and to make the necessary process improvements. Therefore, throughout the text, weak spots in the design, potential improvements, and a path toward an optimized process flow diagram will be identified.

The basic information provided by a PFD can be categorized into one of the following:

1. Process topology
2. Stream information
3. Equipment information

Each aspect of the PFD will be considered separately. After each of the three topics has been addressed, all the information will be gathered and presented in the form of a PFD for the benzene process.

1.2.1 Process Topology

Figure 1.3 is a skeleton process flow diagram for the production of benzene (see also the block flow process diagram in Figure 1.1). This skeleton diagram illustrates the location of the major pieces of equipment and the connections that the process streams make between equipment. The location of and interaction between equipment and process streams are referred to as the process topology.

Equipment is represented symbolically by “icons” that identify specific unit operations. Although the American Society of Mechanical Engineers (ASME) [2] publishes a set of symbols to use in preparing flowsheets, it is not uncommon for companies to use in-house symbols. A comprehensive set of symbols is also given by Austin [3]. Whatever set of symbols is used, there is seldom a problem in identifying the operation represented by each icon. Figure 1.4 contains a list of the symbols used in process diagrams presented in this text. This list covers more than 90% of those needed in fluid (gas or liquid) processes.

Figure 1.3 shows that each major piece of process equipment is identified by a number on the diagram. A list of the equipment numbers along with a brief descriptive name for the equipment is printed along the top of the diagram. The location of these equipment numbers and names roughly corresponds to the horizontal location of the corresponding piece of equipment. The convention for formatting and identifying the process equipment is given in Table 1.2.

Table 1.2 provides the information necessary for the identification of the process equipment icons shown in a PFD. As an example of how to use this information, consider the unit operation P-101A/B and what each number or letter means.

P-101A/B identifies the equipment as a pump.

P-101A/B indicates that the pump is located in area 100 of the plant.

P-101A/B indicates that this specific pump is number 01 in unit 100.

P-101A/B indicates that a backup pump is installed. Thus, there are two identical pumps, P-101A and P-101B. One pump will be operating while the other is idle.

The 100 area designation will be used for the benzene process throughout this text. Other processes presented in the text will carry other area designations. Along the top of the PFD, each piece of process equipment is assigned a descriptive name. From Figure 1.3 it can be seen that Pump P-101 is called the “toluene feed pump.” This name will be commonly used in discussions about the process and is synonymous with P-101.

V-101	P-101A/B	E-101	H-101	R-101	C-101A/B	E-102	V-102	V-103	E-103	E-106	T-101	E-104	V-104	P-102A/B	E-105
Toluene Storage Drum	Toluene Feed Pumps	Feed Preheater	Feed Heater	Reactor	Recycle Gas Compressor	Reactor Effluent Cooler	High-Pres. Phase Sep.	Low-Pres. Phase Sep.	Tower Feed Heater	Benzene Reboiler	Benzene Column	Benzene Condenser	Reflux Drum	Reflux Pumps	Product Cooler

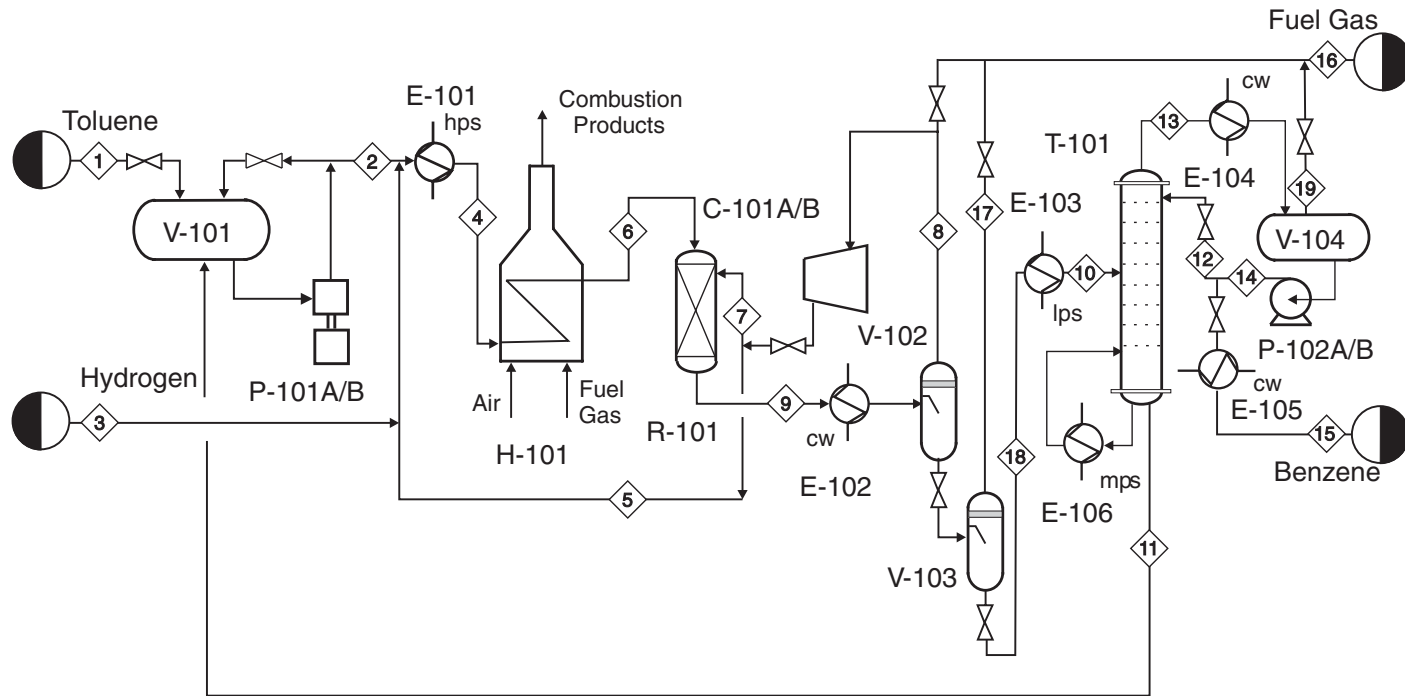

Figure 1.3 Skeleton Process Flow Diagram (PFD) for the Production of Benzene via the Hydrodealkylation of Toluene

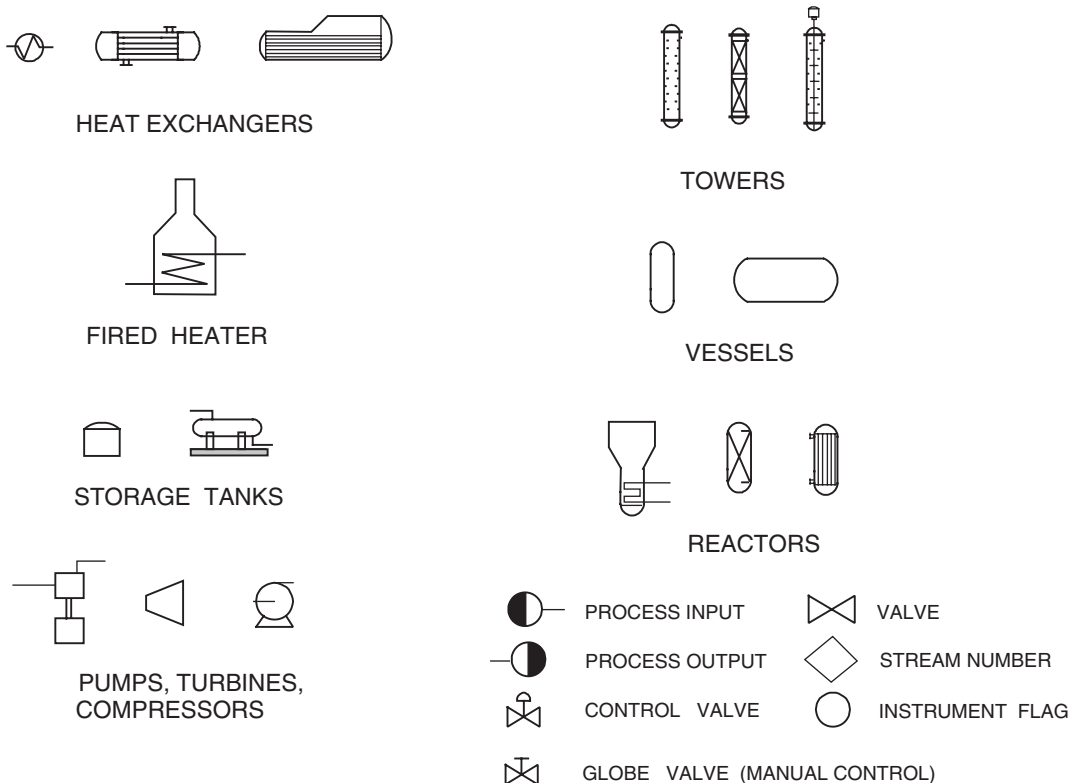

Figure 1.4 Symbols for Drawing Process Flow Diagrams

During the life of the plant, many modifications will be made to the process; often it will be necessary to replace or eliminate process equipment. When a piece of equipment wears out and is replaced by a new unit that provides essentially the same process function as the old unit, then it is not uncommon for the new piece of equipment to inherit the old equipment's name and number (often an additional letter suffix will be used, e.g., H-101 might become H-101A). On the other hand, if a significant process modification takes place, then it is usual to use new equipment numbers and names. Example 1.1, taken from Figure 1.3, illustrates this concept.

Example 1.1

Operators report frequent problems with E-102, which are to be investigated. The PFD for the plant's 100 area is reviewed, and E-102 is identified as the "Reactor Effluent Cooler." The process stream entering the cooler is a mixture of condensable and noncondensable gases at 654°C that are partially condensed to form a two-phase mixture. The coolant is water at 30°C. These conditions characterize a complex heat transfer problem. In addition, operators have noticed that the pressure drop across E-102 fluctuates wildly at certain times, making control of the process difficult. Because of the frequent problems with this exchanger, it is recommended that E-102 be replaced by two separate heat exchangers. The first exchanger cools the effluent gas and generates steam needed in the plant. The second exchanger uses cooling water to reach the desired exit temperature of 38°C. These exchangers are to be designated as E-107 (reactor effluent boiler) and E-108 (reactor effluent condenser).

Table 1.2 Conventions Used for Identifying Process Equipment

Process Equipment	General Format XX-YYZ A/B
	XX are the identification letters for the equipment classification C - Compressor or Turbine E - Heat Exchanger H - Fired Heater P - Pump R - Reactor T - Tower TK - Storage Tank V - Vessel Y designates an area within the plant ZZ is the number designation for each item in an equipment class A/B identifies parallel units or backup units not shown on a PFD
Supplemental Information	Additional description of equipment given on top of PFD

The E-102 designation is retired and not reassigned to the new equipment. There can be no mistake that E-107 and E-108 are new units in this process and that E-102 no longer exists.

1.2.2 Stream Information

Referring back to Figure 1.3, it can be seen that each of the process streams is identified by a number in a diamond box located on the stream. The direction of the stream is identified by one or more arrowheads. The process stream numbers are used to identify streams on the PFD, and the type of information that is typically given for each stream is discussed in the next section.

Also identified in Figure 1.3 are utility streams. Utilities are needed services that are available at the plant. Chemical plants are provided with a range of central utilities that include electricity, compressed air, cooling water, refrigerated water, steam, condensate return, inert gas for blanketing, chemical sewer, wastewater treatment, and flares. A list of the common services is given in Table 1.3, which also provides a guide for the identification of process streams.

Each utility is identified by the initials provided in Table 1.3. As an example, locate E-102 in Figure 1.3. The notation, cw, associated with the nonprocess stream flowing into E-102 indicates that cooling water is used as a coolant.

Electricity used to power motors and generators is an additional utility that is not identified directly on the PFD or in Table 1.3 but is treated separately. Most of the utilities shown are related to equipment that adds or removes heat within the process in order to control temperatures. This is common for most chemical processes.

From the PFD in Figure 1.3, the identification of the process streams is clear. For small diagrams containing only a few operations, the characteristics of the streams such

Table 1.3 Conventions for Identifying Process and Utility Streams

Process Streams	
All conventions shown in Table 1.1 apply.	
Diamond symbol located in flow lines.	
Numerical identification (unique for that stream) inserted in diamond.	
Flow direction shown by arrows on flow lines.	
Utility Streams	
lps	Low-Pressure Steam: 3–5 barg (sat)*
mpps	Medium-Pressure Steam: 10–15 barg (sat)*
hps	High-Pressure Steam: 40–50 barg (sat)*
htm	Heat Transfer Media (Organic): to 400°C
cw	Cooling Water: From Cooling Tower 30°C Returned at Less than 45°C [†]
wr	River Water: From River 25°C Returned at Less than 35°C
rw	Refrigerated Water: In at 5°C Returned at Less than 15°C
rb	Refrigerated Brine: In at –45°C Returned at Less than 0°C
cs	Chemical Wastewater with High COD
ss	Sanitary Wastewater with High BOD, etc.
el	Electric Heat (Specify 220, 440, 660V Service)
bfw	Boiler Feed Water
ng	Natural Gas
fg	Fuel Gas
fo	Fuel Oil
fw	Fire Water
*These pressures are set during the preliminary design stages and typical values vary within the ranges shown.	
[†] Above 45°C, significant scaling occurs.	

as temperatures, pressures, compositions, and flowrates can be shown directly on the figure, adjacent to the stream. This is not practical for a more complex diagram. In this case, only the stream number is provided on the diagram. This indexes the stream to information on a flow summary or stream table, which is often provided below the process flow diagram. In this text the flow summary table is provided as a separate attachment to the PFD.

The stream information that is normally given in a flow summary table is given in Table 1.4. It is divided into two groups—required information and optional information—that may be important to specific processes. The flow summary table, for Figure 1.3, is given in Table 1.5 and contains all the required information listed in Table 1.4.

With information from the PFD (Figure 1.3) and the flow summary table (Table 1.5), problems regarding material balances and other problems are easily analyzed. Example 1.2 and Example 1.3 are provided to offer experience in working with information from the PFD.

Table 1.4 Information Provided in a Flow Summary

Required Information
Stream Number
Temperature (°C)
Pressure (bar)
Vapor Fraction
Total Mass Flowrate (kg/h)
Total Mole Flowrate (kmol/h)
Individual Component Flowrates (kmol/h)
Optional Information
Component Mole Fractions
Component Mass Fractions
Individual Component Flowrates (kg/h)
Volumetric Flowrates (m ³ /h)
Significant Physical Properties
Density
Viscosity
Other
Thermodynamic Data
Heat Capacity
Stream Enthalpy
K-values
Stream Name

Table 1.5 Flow Summary Table for the Benzene Process Shown in Figure 1.3 (and Figure 1.5)

Stream Number	1	2	3	4	5	6	7	8
Temperature (°C)	25	59	25	225	41	600	41	38
Pressure (bar)	1.90	25.8	25.5	25.2	25.5	25.0	25.5	23.9
Vapor Fraction	0.0	0.0	1.00	1.0	1.0	1.0	1.0	1.0
Mass Flow (tonne/h)	10.0	13.3	0.82	20.5	6.41	20.5	0.36	9.2
Mole Flow (kmol/h)	108.7	144.2	301.0	1204.4	758.8	1204.4	42.6	1100.8
Component Flowrates (kmol/h)								
Hydrogen	0.0	0.0	286.0	735.4	449.4	735.4	25.2	651.9
Methane	0.0	0.0	15.0	317.3	302.2	317.3	16.95	438.3
Benzene	0.0	1.0	0.0	7.6	6.6	7.6	0.37	9.55
Toluene	108.7	143.2	0.0	144.0	0.7	144.0	0.04	1.05

Example 1.2

Check the overall material balance for the benzene process shown in Figure 1.3. From the figure, identify the input streams as Stream 1 (toluene feed) and Stream 3 (hydrogen feed) and the output streams as Stream 15 (product benzene) and Stream 16 (fuel gas). From the flow summary table, these flows are listed as (units are in 10^3 kg/h):

Input:		Output:	
Stream 3	0.82	Stream 15	8.21
Stream 1	<u>10.00</u>	Stream 16	<u>2.61</u>
Total	<u>10.82</u> $\times 10^3$ kg/h	Total	<u>10.82</u> $\times 10^3$ kg/h

Balance is achieved since Output = Input.

Example 1.3

Determine the conversion per pass of toluene to benzene in R-101 in Figure 1.3. Conversion is defined as

$$\epsilon = (\text{benzene produced}) / (\text{total toluene introduced})$$

From the PFD, the input streams to R-101 are shown as Stream 6 (reactor feed) and Stream 7 (recycle gas quench), and the output stream is Stream 9 (reactor effluent stream). From the information in Table 1.5 (units are kmol/h):

$$\text{Toluene introduced} = 144 \text{ (Stream 6)} + 0.04 \text{ (Stream 7)} = 144.04 \text{ kmol/h}$$

$$\begin{aligned} \text{Benzene produced} &= 116 \text{ (Stream 9)} - 7.6 \text{ (Stream 6)} - 0.37 \text{ (Stream 7)} \\ &= 108.03 \text{ kmol/h} \end{aligned}$$

$$\epsilon = 108.03 / 144.04 = 0.75$$

Alternatively, the following can be written:

$$\begin{aligned} \text{Moles of benzene produced} &= \text{Toluene in} - \text{Toluene out} = 144.04 - 36.00 \\ &= 108.04 \text{ kmol/h} \end{aligned}$$

$$\epsilon = 108.04 / 144.04 = 0.75$$

9	10	11	12	13	14	15	16	17	18	19
654	90	147	112	112	112	38	38	38	38	112
24.0	2.6	2.8	3.3	2.5	3.3	2.3	2.5	2.8	2.9	2.5
1.0	0.0	0.0	0.0	1.0	0.0	0.0	1.0	1.0	0.0	1.0
20.9	11.6	3.27	14.0	22.7	22.7	8.21	2.61	0.07	11.5	0.01
1247.0	142.2	35.7	185.2	291.6	290.7	105.6	304.2	4.06	142.2	0.90
652.6	0.02	0.0	0.0	0.02	0.0	0.0	178.0	0.67	0.02	0.02
442.3	0.88	0.0	0.0	0.88	0.0	0.0	123.05	3.10	0.88	0.88
116.0	106.3	1.1	184.3	289.46	289.46	105.2	2.85	0.26	106.3	0.0
36.0	35.0	34.6	0.88	1.22	1.22	0.4	0.31	0.03	35.0	0.0

Table 1.6 Equipment Descriptions for PFD and P&IDs

Equipment Type
Description of Equipment
Towers
Size (height and diameter), Pressure, Temperature Number and Type of Trays Height and Type of Packing Materials of Construction
Heat Exchangers
Type: Gas-Gas, Gas-Liquid, Liquid-Liquid, Condenser, Vaporizer Process: Duty, Area, Temperature, and Pressure for both streams Number of Shell and Tube Passes Materials of Construction: Tubes and Shell
Tanks and Vessels
Height, Diameter, Orientation, Pressure, Temperature, Materials of Construction
Pumps
Flow, Discharge Pressure, Temperature, ΔP , Driver Type, Shaft Power, Materials of Construction
Compressors
Actual Inlet Flowrate, Temperature, Pressure, Driver Type, Shaft Power, Materials of Construction
Heaters (Fired)
Type, Tube Pressure, Tube Temperature, Duty, Fuel, Material of Construction
Other
Provide Critical Information

1.2.3 Equipment Information

The final element of the PFD is the equipment summary. This summary provides the information necessary to estimate the costs of equipment and furnish the basis for the detailed design of equipment. Table 1.6 provides the information needed for the equipment summary for most of the equipment encountered in fluid processes.

The information presented in Table 1.6 is used in preparing the equipment summary portion of the PFD for the benzene process. The equipment summary for the benzene process is presented in Table 1.7, and details of how to estimate and choose various equipment parameters are discussed in Chapter 11.

Table 1.7 Equipment Summary for Toluene Hydrodealkylation PFD

Heat Exchangers	E-101	E-102	E-103	E-104	E-105	E-106
Type	Fl.H.	Fl.H.	MDP	Fl.H.	MDP	Fl.H.
Area (m ²)	36	763	11	35	12	80
Duty (MJ/h)	15,190	46,660	1055	8335	1085	9045
Shell						
Temp. (°C)	225	654	160	112	112	185
Pres. (bar)	26	24	6	3	3	11
Phase	Vap.	Par. Cond.	Cond.	Cond.	l	Cond.
MOC	316SS	316SS	CS	CS	CS	CS
Tube						
Temp. (°C)	258	40	90	40	40	147
Pres. (bar)	42	3	3	3	3	3
Phase	Cond.	l	l	l	l	Vap.
MOC	316SS	316SS	CS	CS	CS	CS
Vessels/Tower/ Reactors						
	V-101	V-102	V-103	V-104	T-101	R-101
Temperature (°C)	55	38	38	112	147	660
Pressure (bar)	2.0	24	3.0	2.5	3.0	25
Orientation	Horizontal	Vertical	Vertical	Horizontal	Vertical	Vertical
MOC	CS	CS	CS	CS	CS	316SS
Size						
Height/Length (m)	5.9	3.5	3.5	3.9	29	14.2
Diameter (m)	1.9	1.1	1.1	1.3	1.5	2.3
Internals		s.p.	s.p.		42 sieve trays 316SS	Catalyst packed bed-10m
Pumps/Compressors						
	P-101 (A/B)	P-102 (A/B)	C-101 (A/B)	Heater		H-101
Flow (kg/h)	13,000	22,700	6770	Type		Fired
Fluid Density (kg/m ³)	870	880	8.02	MOC		316SS
Power (shaft) (kW)	14.2	3.2	49.1	Duty (MJ/h)		27,040
Type/Drive	Recip./ Electric	Centrf./ Electric	Centrf./ Electric	Radiant Area (m ²)		106.8
Efficiency (Fluid Power/Shaft Power)	0.75	0.50	0.75	Convective Area (m ²)		320.2

(continued)

Table 1.7 Equipment Summary for Toluene Hydrodealkylation PFD (continued)

Pumps/Compressors	P-101 (A/B)	P-102 (A/B)	C-101 (A/B)	Heater	H-101
MOC	CS	CS	CS	Tube P (bar)	26.0
Temp. (in) (°C)	55	112	38		
Pres. (in) (bar)	1.2	2.2	23.9		
Pres. (out) (bar)	27.0	4.4	25.5		
Key:					
MOC	Materials of construction	Par	Partial		
316SS	Stainless steel type 316	F.H.	Fixed head		
CS	Carbon steel	Fl.H.	Floating head		
Vap	Stream being vaporized	Rbl	Reboiler		
Cond	Stream being condensed	s.p.	Splash plate		
Recipr.	Reciprocating	l	Liquid		
Centrf.	Centrifugal	MDP	Multiple double pipe		

1.2.4 Combining Topology, Stream Data, and Control Strategy to Give a PFD

Up to this point, the amount of process information displayed on the PFD has been kept to a minimum. A more representative example of a PFD for the benzene process is shown in Figure 1.5. This diagram includes all of the elements found in Figure 1.3, some of the information found in Table 1.5, plus additional information on the major control loops used in the process.

Stream information is added to the diagram by attaching “information flags.” The shape of the flags indicates the specific information provided on the flag. Figure 1.6 illustrates all the flags used in this text. These information flags play a dual role. They provide information needed in the plant design leading to plant construction and in the analysis of operating problems during the life of the plant. Flags are mounted on a staff connected to the appropriate process stream. More than one flag may be mounted on a staff. Example 1.4 illustrates the different information displayed on the PFD.

Example 1.4

Locate Stream 1 in Figure 1.5 and note that immediately following the stream identification diamond a staff is affixed. This staff carries three flags containing the following stream data:

1. Temperature of 25°C
2. Pressure of 1.9 bar
3. Mass flowrate of 10.0×10^3 kg/h

The units for each process variable are indicated in the key provided at the left-hand side of Figure 1.5.

With the addition of the process control loops and the information flags, the PFD starts to become cluttered. Therefore, in order to preserve clarity, it is necessary to limit what data are presented with these information flags. Fortunately, flags on a PFD are easy to add, remove, and change, and even temporary flags may be provided from time to time.

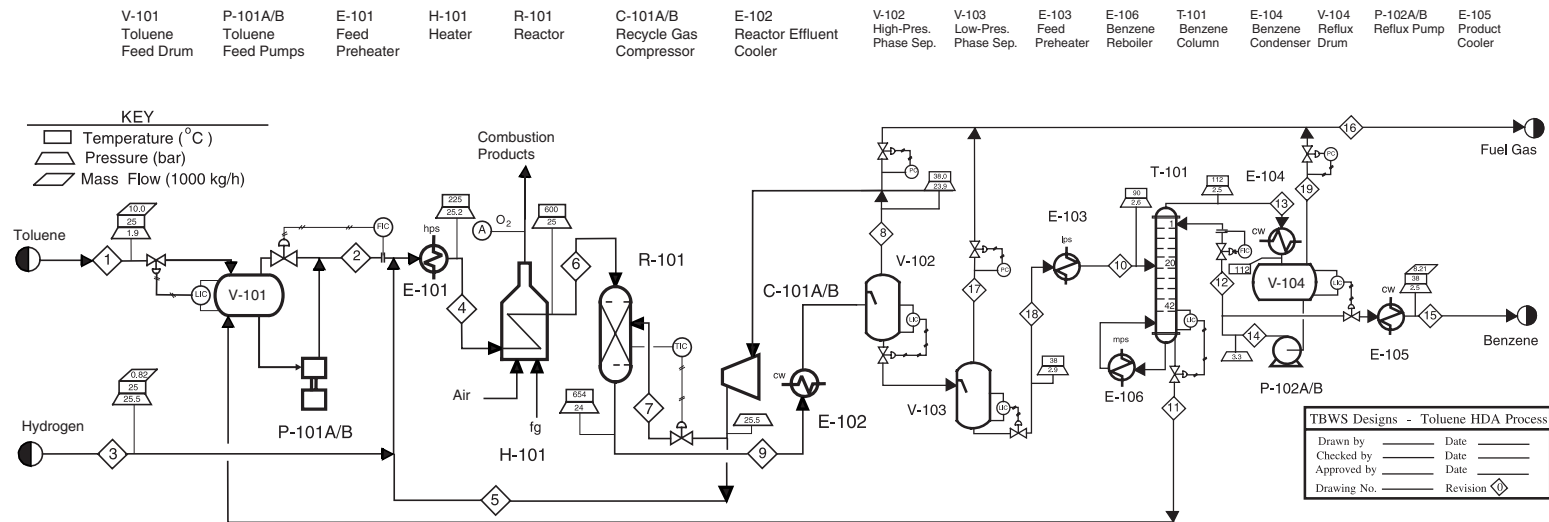

Figure 1.5 Benzene Process Flow Diagram (PFD) for the Production of Benzene via the Hydrodealkylation of Toluene





	STREAM I.D.
	TEMPERATURE
	PRESSURE
	LIQUID FLOWRATE
	GAS FLOWRATE
	MOLAR FLOWRATE
	MASS FLOWRATE

Figure 1.6 Symbols for Stream Identification

The information provided on the flags is also included in the flow summary table. However, often it is far more convenient when analyzing the PFD to have certain data directly on the diagram.

Not all process information is of equal importance. General guidelines for what data should be included in information flags on the PFD are difficult to define. However, at a minimum, information critical to the safety and operation of the plant should be given. This includes temperatures and pressures associated with the reactor, flowrates of feed and product streams, and stream pressures and temperatures that are substantially higher than the rest of the process. Additional needs are process specific. Examples 1.5–1.7 illustrate where and why information should be included directly on a PFD.

Example 1.5

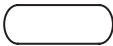
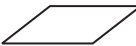
Acrylic acid is temperature sensitive and polymerizes at 90°C when present in high concentration. It is separated by distillation and leaves from the bottom of the tower. In this case, a temperature and pressure flag would be provided for the stream leaving the reboiler.

Example 1.6

In the benzene process, the feed to the reactor is substantially hotter than the rest of the process and is crucial to the operation of the process. In addition, the reaction is exothermic, and the reactor effluent temperature must be carefully monitored. For this reason Stream 6 (entering) and Stream 9 (leaving) have temperature flags.

Example 1.7

The pressures of the streams to and from R-101 in the benzene process are also important. The difference in pressure between the two streams gives the pressure drop across the reactor. This, in turn, gives an indication of any maldistribution of gas through the catalyst beds. For this reason, pressure flags are also included on Streams 6 and 9.

Of secondary importance is the fact that flags are useful in reducing the size of the flow summary table. For pumps, compressors, and heat exchangers, the mass flows are the same for the input and output streams, and complete entries in the stream table are not necessary. If the input (or output) stream is included in the stream table, and a flag is added to provide the temperature (in the case of a heat exchanger) or the pressure (in the case of a pump) for the other stream, then there is no need to present this stream in the flow summary table. Example 1.8 illustrates this point.

Example 1.8

Follow Stream 13 leaving the top of the benzene column in the benzene PFD given in Figure 1.5 and in Table 1.5. This stream passes through the benzene condenser, E-104, into the reflux drum, V-104. The majority of this stream then flows into the reflux pump, P-102, and leaves as Stream 14, while the remaining noncondensables leave the reflux drum in Stream 19. The mass flowrate and component flowrates of all these streams are given in Table 1.5. The stream leaving E-104 is not included in the stream table. Instead, a flag giving the temperature (112°C) was provided on the diagram (indicating condensation without subcooling). An additional flag, showing the pressure following the pump, is also shown. In this case the entry for Stream 14 could be omitted from the stream table, because it is simply the sum of Streams 12 and 15, and no information would be lost.

More information could be included in Figure 1.5 had space for the diagram not been limited by text format. It is most important that the PFD remain uncluttered and easy to follow in order to avoid errors and misunderstandings. Adding additional material to Figure 1.5 risks sacrificing clarity.

The flow table presented in Table 1.5, the equipment summary presented in Table 1.7, and Figure 1.5 taken together constitute all the information contained on a commercially produced PFD.

The PFD is the first comprehensive diagram drawn for any new plant or process. It provides all of the information needed to understand the chemical process. In addition, sufficient information is given on the equipment, energy, and material balances to establish process control protocol and to prepare cost estimates to determine the economic viability of the process.

Many additional drawings are needed to build the plant. All the process information required can be taken from this PFD. As described in the narrative at the beginning of this chapter, the development of the PFD is most often carried out by the operating company. Subsequent activities in the design of the plant are often contracted out.

The value of the PFD does not end with the construction of the plant. It remains the document that best describes the process, and it is used in the training of operators and new engineers. It is consulted regularly to diagnose operating problems that arise and to predict the effects of changes on the process.

1.3 PIPING AND INSTRUMENTATION DIAGRAM (P&ID)

The piping and instrumentation diagram (P&ID), also known as mechanical flow diagram (MFD), provides information needed by engineers to begin planning for the construction of the plant. The P&ID includes every mechanical aspect of the plant except the information given in Table 1.8. The general conventions used in drawing P&IDs are given in Table 1.9.

Table 1.8 Exclusions from Piping and Instrumentation Diagram

- | |
|--|
| <ol style="list-style-type: none"> 1. Operating Conditions T, P 2. Stream Flows 3. Equipment Locations 4. Pipe Routing <ol style="list-style-type: none"> a. Pipe Lengths b. Pipe Fittings 5. Supports, Structures, and Foundations |
|--|

Each PFD will require many P&IDs to provide the necessary data. Figure 1.7 is a representative P&ID for the distillation section of the benzene process shown in Figure 1.5. The P&ID presented in Figure 1.7 provides information on the piping, and this is included as part of the diagram. As an alternative, each pipe can be numbered, and the specifics of every line can be provided in a separate table accompanying this diagram. When possible, the physical size of the larger-sized unit operations is reflected by the size of the symbol in the diagram.

Utility connections are identified by a numbered box in the P&ID. The number within the box identifies the specific utility. The key identifying the utility connections is shown in a table on the P&ID.

All process information that can be measured in the plant is shown on the P&ID by circular flags. This includes the information to be recorded and used in process control

Table 1.9 Conventions in Constructing Piping and Instrumentation Diagrams

For Equipment—Show Every Piece Including
Spare Units Parallel Units Summary Details of Each Unit
For Piping—Include All Lines Including Drains and Sample Connections, and Specify
Size (Use Standard Sizes) Schedule (Thickness) Materials of Construction Insulation (Thickness and Type)
For Instruments—Identify
Indicators Recorders Controllers Show Instrument Lines
For Utilities—Identify
Entrance Utilities Exit Utilities Exit to Waste Treatment Facilities

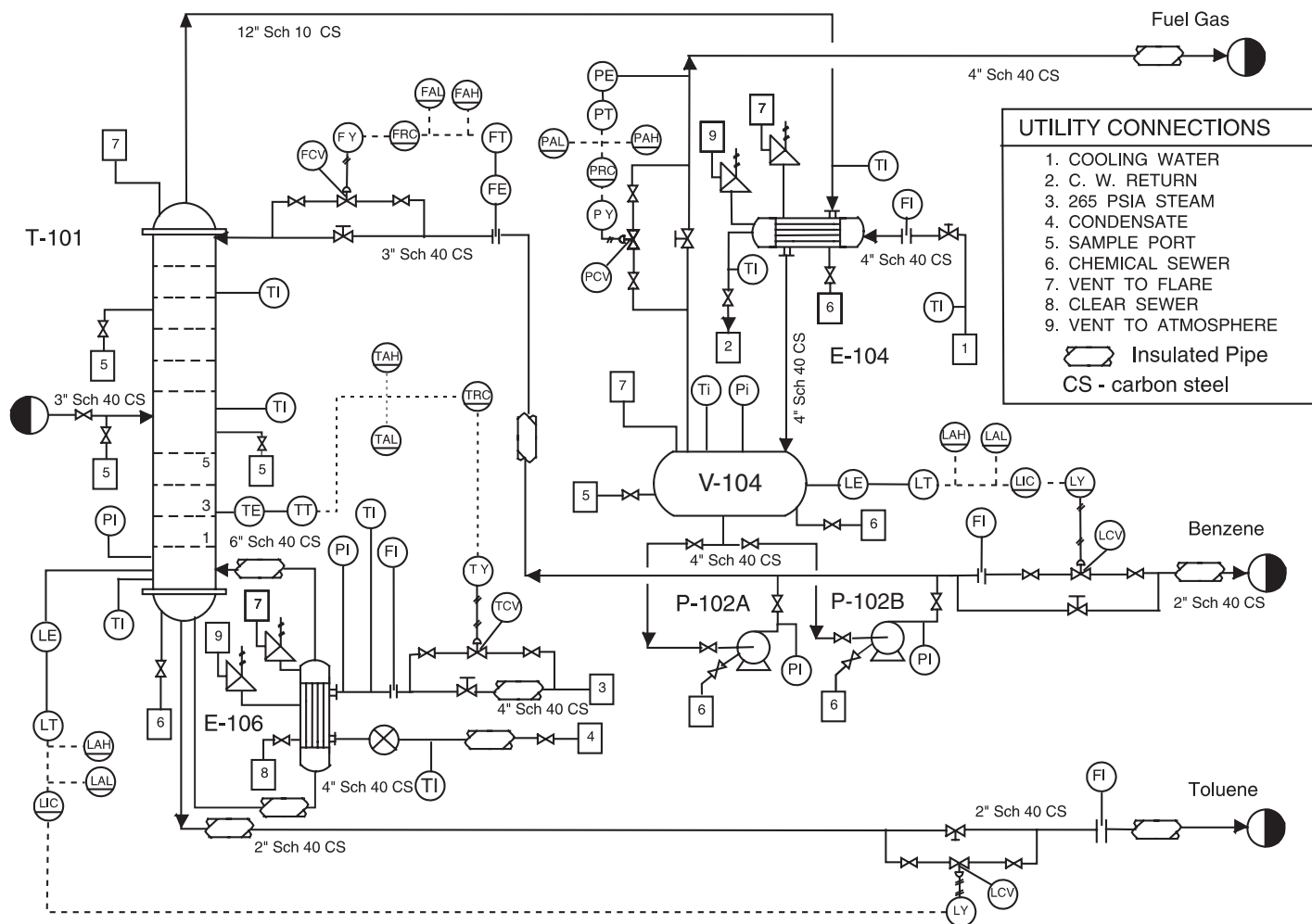



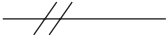
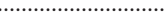

Figure 1.7 Piping and Instrumentation Diagram for Benzene Distillation (adapted from Kauffman, D., *Flow Sheets and Diagrams*, AIChE Modular Instruction, Series G: Design of Equipment, series editor J. Beckman, AIChE, New York, 1986, vol. 1, Chapter G.1.5, AIChE copyright © 1986 AIChE, all rights reserved)

loops. The circular flags on the diagram indicate where the information is obtained in the process and identify the measurements taken and how the information is dealt with. Table 1.10 summarizes the conventions used to identify information related to instrumentation and control. Example 1.9 illustrates the interpretation of instrumentation and control symbols.

Table 1.10 Conventions Used for Identifying Instrumentation on P&IDs (ISA standard ISA-S5-1, [4])

Location of Instrumentation	
	Instrument Located in Plant
	Instrument Located on Front of Panel in Control Room
	Instrument Located on Back of Panel in Control Room
Meanings of Identification Letters (XY)	
<i>First Letter (X)</i>	<i>Second or Third Letter (Y)</i>
A Analysis	Alarm
B Burner Flame	
C Conductivity	Control
D Density or Specific Gravity	
E Voltage	Element
F Flowrate	
H Hand (Manually Initiated)	High
I Current	Indicate
J Power	
K Time or Time Schedule	Control Station
L Level	Light or Low
M Moisture or Humidity	Middle or Intermediate
O	Orifice
P Pressure or Vacuum	Point
Q Quantity or Event	
R Radioactivity or Ratio	Record or print
S Speed or Frequency	Switch
T Temperature	Transmit
V Viscosity	Valve, Damper, or Louver
W Weight	Well
Y	Relay or Compute
Z Position	Drive
Identification of Instrument Connections	
	Capillary
	Pneumatic
	Electrical

Example 1.9

Consider the benzene product line leaving the right-hand side of the P&ID in Figure 1.7. The flowrate of this stream is controlled by a control valve that receives a signal from a level measuring element placed on V-104. The sequence of instrumentation is as follows:

A level sensing element (LE) is located on the reflux drum V-104. A level transmitter (LT) also located on V-104 sends an electrical signal (designated by a dashed line) to a level indicator and controller (LIC). This LIC is located in the control room on the control panel or console (as indicated by the horizontal line under LIC) and can be observed by the operators. From the LIC, an electrical signal is sent to an instrument (LY) that computes the correct valve position and in turn sends a pneumatic signal (designated by a solid line with cross hatching) to activate the control valve (LCV). In order to warn operators of potential problems, two alarms are placed in the control room. These are a high-level alarm (LAH) and a low-level alarm (LAL), and they receive the same signal from the level transmitter as does the controller.

This control loop is also indicated on the PFD of Figure 1.5. However, the details of all the instrumentation are condensed into a single symbol (LIC), which adequately describes the essential process control function being performed. The control action that takes place is not described explicitly in either drawing. However, it is a simple matter to infer that if there is an increase in the level of liquid in V-104, the control valve will open slightly and the flow of benzene product will increase, tending to lower the level in V-104. For a decrease in the level of liquid, the valve will close slightly.

The details of the other control loops in Figures 1.5 and 1.7 are left to problems at the end of this chapter. It is worth mentioning that in virtually all cases of process control in chemical processes, the final control element is a valve. Thus, all control logic is based on the effect that a change in a given flowrate has on a given variable. The key to understanding the control logic is to identify which flowrate is being manipulated to control which variable. Once this has been done, it is a relatively simple matter to see in which direction the valve should change in order to make the desired change in the control variable. The response time of the system and type of control action used—for example, proportional, integral, or differential—are left to the instrument engineers and are not covered in this text.

The final control element in nearly all chemical process control loops is a valve.

The P&ID is the last stage of process design and serves as a guide for those who will be responsible for the final design and construction. Based on this diagram,

1. Mechanical engineers and civil engineers will design and install pieces of equipment.
2. Instrument engineers will specify, install, and check control systems.
3. Piping engineers will develop plant layout and elevation drawings.
4. Project engineers will develop plant and construction schedules.

Before final acceptance, the P&IDs serve as a checklist against which each item in the plant is checked.

The P&ID is also used to train operators. Once the plant is built and is operational, there are limits to what operators can do. About all that can be done to correct or alter performance of the plant is to open, close, or change the position of a valve. Part of the training would pose situations and require the operators to be able to describe what

specific valve should be changed, how it should be changed, and what to observe in order to monitor the effects of the change. Plant simulators (similar to flight simulators) are sometimes involved in operator training. These programs are sophisticated, real-time process simulators that show a trainee operator how quickly changes in controlled variables propagate through the process. It is also possible for such programs to display scenarios of process upsets so that operators can get training in recognizing and correcting such situations. These types of programs are very useful and cost-effective in initial operator training. However, the use of P&IDs is still very important in this regard.

The P&ID is particularly important for the development of start-up procedures when the plant is not under the influence of the installed process control systems. An example of a start-up procedure is given in Example 1.10.

Example 1.10

Consider the start-up of the distillation column shown in Figure 1.7. What sequence would be followed? The procedure is beyond the scope of this text, but it would be developed from a series of questions such as

- a. What valve should be opened first?
 - b. What should be done when the temperature of . . . reaches . . . ?
 - c. To what value should the controller be set?
 - d. When can the system be put on automatic control?
-

These last three sections have followed the development of a process from a simple BFD through the PFD and finally to the P&ID. Each step showed additional information. This can be seen by following the progress of the distillation unit as it moves through the three diagrams described.

1. **Block Flow Diagram (BFD) (see Figure 1.1):** The column was shown as a part of one of the three process blocks.
2. **Process Flow Diagram (PFD) (see Figure 1.5):** The column was shown as the following set of individual equipment: a tower, condenser, reflux drum, reboiler, reflux pumps, and associated process controls.
3. **Piping and Instrumentation Diagram (P&ID) (see Figure 1.7):** The column was shown as a comprehensive diagram that includes additional details such as pipe sizes, utility streams, sample taps, numerous indicators, and so on. It is the only unit operation on the diagram.

The value of these diagrams does not end with the start-up of the plant. The design values on the diagram are changed to represent the actual values determined under normal operating conditions. These conditions form a “base case” and are used to compare operations throughout the life of the plant.

1.4 ADDITIONAL DIAGRAMS

During the planning and construction phases of a new project, many additional diagrams are needed. Although these diagrams do not possess additional process information, they are essential to the successful completion of the project. Computers are being used more and more to do the tedious work associated with all of these drawing details. The creative

work comes in the development of the concepts provided in the BFD and the process development required to produce the PFD. The computer can help with the drawings but cannot create a new process. Computers are valuable in many aspects of the design process where the size of equipment to do a specific task is to be determined. Computers may also be used when considering performance problems that deal with the operation of existing equipment. However, they are severely limited in dealing with diagnostic problems that are required throughout the life of the plant.

The diagrams presented here are in both American Engineering and SI units. The most noticeable exception is in the sizing of piping, where pipes are specified in inches and pipe schedule. This remains the way they are produced and purchased in the United States. A process engineer today must be comfortable with SI, conventional metric, and American (formerly British, who now use SI exclusively) Engineering units.

These additional diagrams are discussed briefly below.

A **utility flowsheet** may be provided that shows all the headers for utility inputs and outputs available along with the connections needed to the process. It provides information on the flows and characteristics of the utilities used by the plant.

Vessel sketches, logic ladder diagrams, wiring diagrams, site plans, structural support diagrams, and many other drawings are routinely used but add little to our understanding of the basic chemical processes that take place.

Additional drawings are necessary to locate all of the equipment in the plant. **Plot plans** and **elevation diagrams** are provided that locate the placement and elevation of all of the major pieces of equipment such as towers, vessels, pumps, heat exchangers, and so on. When constructing these drawings, it is necessary to consider and to provide for access for repairing equipment, removing tube bundles from heat exchangers, replacement of units, and so on. What remains to be shown is the addition of the structural support and piping.

Piping isometrics are drawn for every piece of pipe required in the plant. These drawings are 3-D sketches of the pipe run, indicating the elevations and orientation of each section of pipe. In the past, it was also common for comprehensive plants to build a **scale model** so the system could be viewed in three dimensions and modified to remove any potential problems. Over the past thirty years, scale models have been replaced by three-dimensional **computer aided design (CAD)** programs that are capable of representing the plant as-built in three dimensions. They provide an opportunity to view the local equipment topology from any angle at any location inside the plant. One can actually “walk through” the plant and preview what will be seen when the plant is built. The ability to “view” the plant before construction will be made even more realistic with the help of **virtual reality** software. With this new tool, it is possible not only to walk through the plant but also to “touch” the equipment, turn valves, climb to the top of distillation columns, and so on. In the next section, the information needed to complete a preliminary plant layout design is reviewed, and the logic used to locate the process units in the plant and how the elevations of different equipment are determined are briefly explained.

1.5 THREE-DIMENSIONAL REPRESENTATION OF A PROCESS

As mentioned earlier, the major design work products, both chemical and mechanical, are recorded on two-dimensional diagrams (PFD, P&ID, etc.). However, when it comes to the construction of the plant, there are many issues that require a three-dimensional representation of the process. For example, the location of shell-and-tube exchangers must allow for tube bundle removal for cleaning and repair. Locations of pumps must allow for access for maintenance and replacement. For compressors, this access may

also require that a crane be able to remove and replace a damaged drive. Control valves must be located at elevations that allow operator access. Sample ports and instrumentation must also be located conveniently. For anyone who has toured a moderate-to-large chemical facility, the complexity of the piping and equipment layout is immediately apparent. Even for experienced engineers, the review of equipment and piping topology is far easier to accomplish in 3-D than 2-D. Due to the rapid increase in computer power and advanced software, such representations are now done routinely using the computer. In order to “build” an electronic representation of the plant in 3-D, all the information in the previously mentioned diagrams must be accessed and synthesized. This in itself is a daunting task, and a complete accounting of this process is well beyond the scope of this text. However, in order to give the reader a flavor of what can now be accomplished using such software, a brief review of the principles of plant layout design will be given. A more detailed account involving a virtual plant tour of the dimethyl ether (DME) plant (Appendix B.1) is given on the CD accompanying this book.

For a complete, detailed analysis of the plant layout, all equipment sizes, piping sizes, PFDs, P&IDs, and all other information should be known. However, for this description, a preliminary plant layout based on information given in the PFD of Figure B.1.1 is considered. Using this figure and the accompanying stream tables and equipment summary table (Tables B.1.1 and B.1.3), the following steps are followed:

1. *The PFD is divided into logical subsystems.* For the DME process, there are three logical subsections, namely, the feed and reactor section, the DME purification section, and the methanol separation and recycle section. These sections are shown as dotted lines on Figure 1.8.
2. *For each subsystem, a preliminary plot plan is created.* The topology of the plot plan depends on many factors, the most important of which are discussed below.

In general, the layout of the plot plan can take one of two basic configurations: the grade-level, horizontal, in-line arrangement and the structure-mounted vertical arrangement [5]. The grade-level, horizontal, in-line arrangement will be used for the DME facility. In this arrangement, the process equipment units are aligned on either side of a pipe rack that runs through the middle of the process unit. The purpose of the pipe rack is to carry piping for utilities, product, and feed to and from the process unit. Equipment is located on either side of the pipe rack, which allows for easy access. In addition, vertical mounting of equipment is usually limited to a single level. This arrangement generally requires a larger “footprint” and, hence, more land than does the structure-mounted vertical arrangement. The general arrangement for these layout types is shown in Figure 1.9.

The minimum spacing between equipment should be set early on in the design. These distances are set for safety purposes and should be set with both local and national codes in mind. A comprehensive list of the recommended minimum distances between process equipment is given by Bausbacher and Hunt [5]. The values for some basic process equipment are listed in Table 1.11.

The sizing of process equipment should be completed and the approximate location on the plot plan determined. Referring to Table B.1.3 for equipment specifications gives some idea of key equipment sizes. For example, the data given for the reflux drums V-202 and V-203, reactor R-201, and towers T-201 and T-202 are sufficient to sketch these units on the plot plan. However, pump sizes must be obtained from vendors or previous jobs, and additional calculations for heat exchangers must be done to estimate their required footprint on the plot plan. Calculations to illustrate the estimation of equipment footprints are given in Example 1.11.

P-1001A/B V-1001 E-1001 R-1001 E-1002 E-1003 T-1001 E-1004 E-1005 V-1002 P-1002A/B E-1006 T-1002 E-1007 V-1003 P-1003A/B E-1008
 Feed Pump Feed Methanol Reactor Reactor DME DME DME DME DME DME DME Reflux Methanol Methanol Methanol Methanol Methanol Wastewater
 Vessel Preheater Cooler Cooler Tower Reboiler Condenser Reflux Pumps Reboiler Tower Condenser Reflux Pumps Cooler

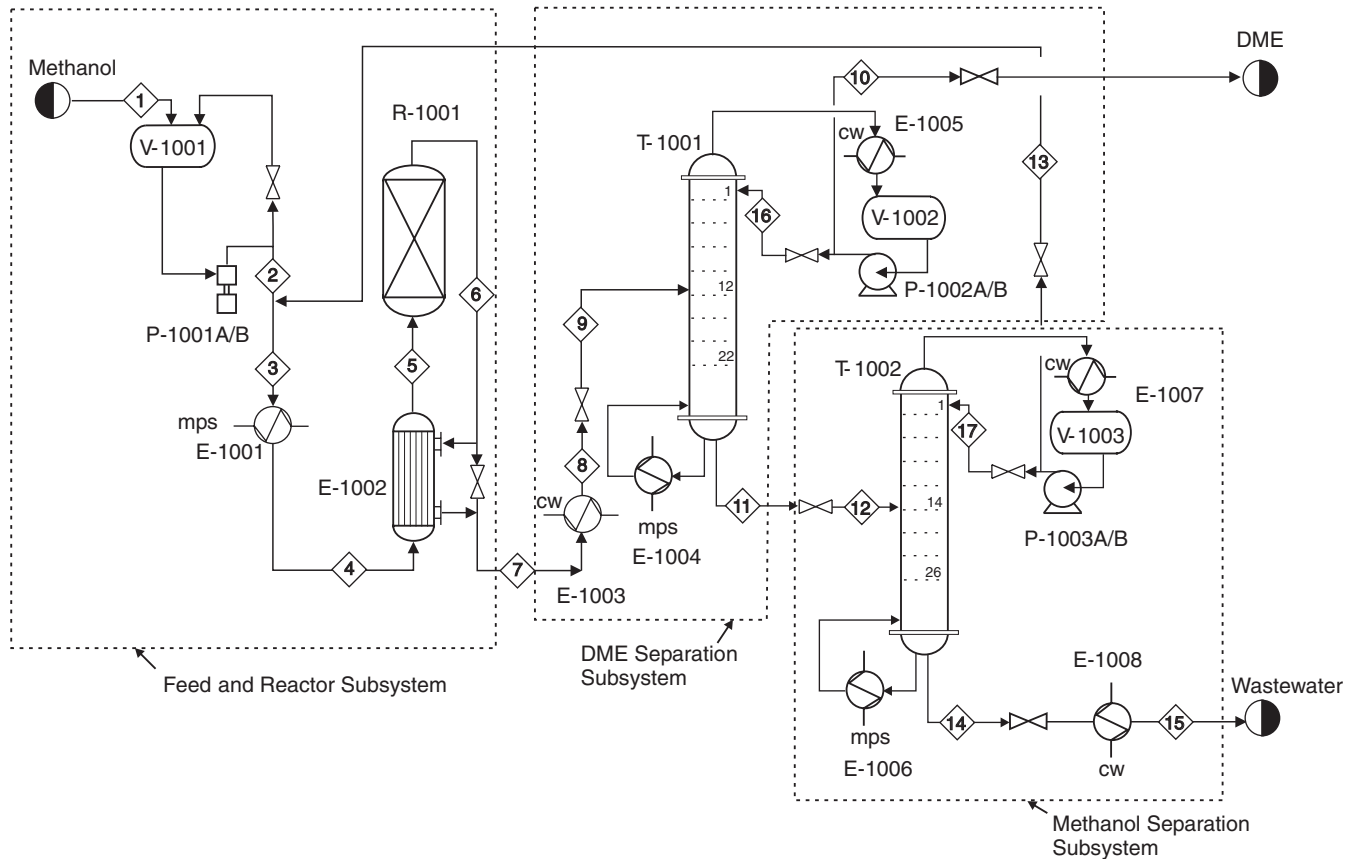

Figure 1.8 Subsystems for Preliminary Plan Layout for DME Process

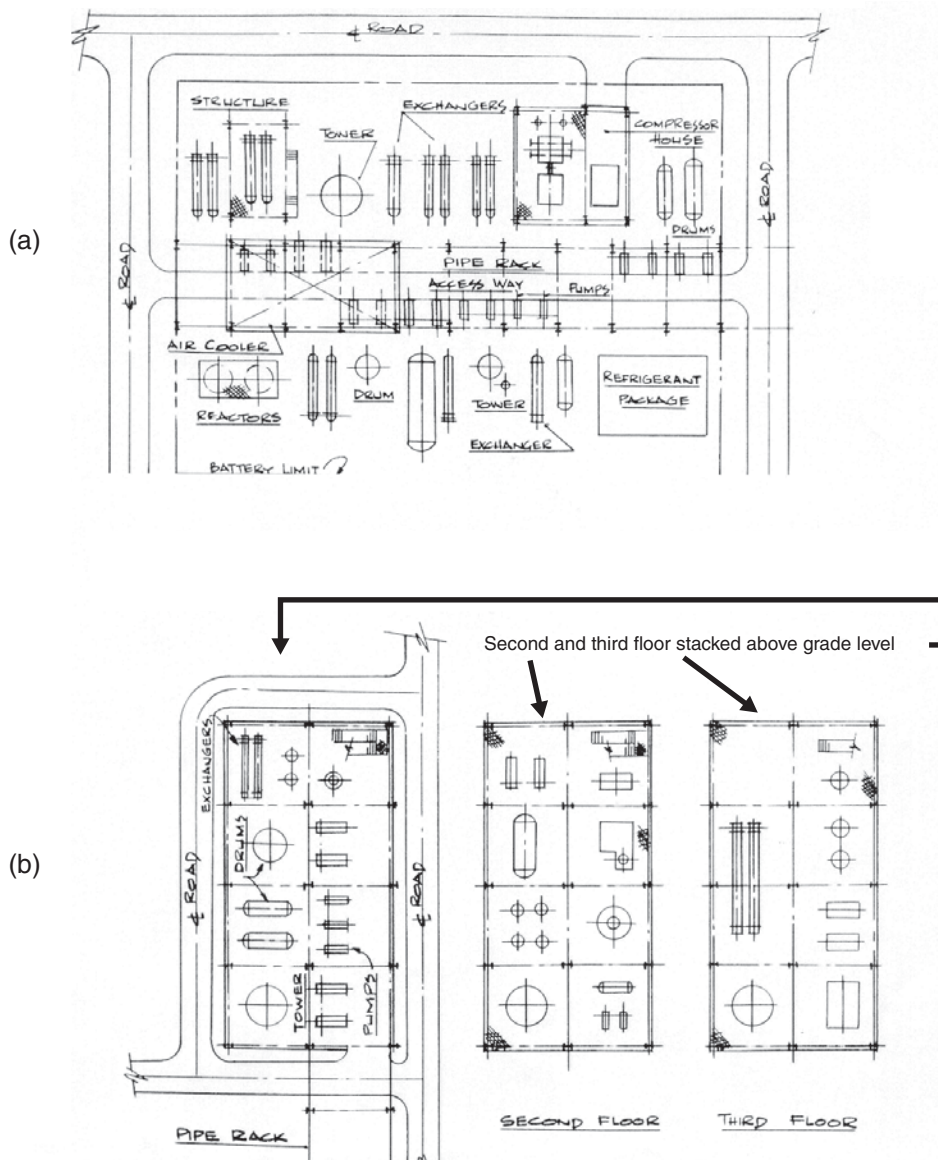

Figure 1.9 Different Types of Plant Layout: (a) Grade-Mounted, Horizontal, In-line Arrangement, and (b) Structure-Mounted Vertical Arrangement (Source: *Process Plant Layout and Piping Design*, by E. Bausbacher and R. Hunt, © 1994, reprinted by permission of Pearson Education, Inc., Upper Saddle River, NJ)

Example 1.11

Estimate the footprint for E-202 in the DME process.
From Table B.1.3 the following information can be found:

Floating-Head Shell-and-Tube design

Area = 171 m²

Hot Side—Temperatures: in at 364°C and out at 281°C

Cold Side—Temperatures: in at 154°C and out at 250°C

Choose a two-shell pass and four-tube pass exchanger

Area per shell = $171/2 = 85.5 \text{ m}^2$

Using 12 ft, 1-in OD tubes, 293 tubes per shell are needed

Assuming the tubes are laid out on a $1\frac{1}{4}$ -in square pitch, a 27-in ID shell is required.

Assume that the front and rear heads (where the tube fluid turns at the end of the exchanger) are 30 in in diameter and require 2 ft each (including flanges), and that the two shells are stacked on top of each other. The footprint of the exchanger is given in Figure E1.11.

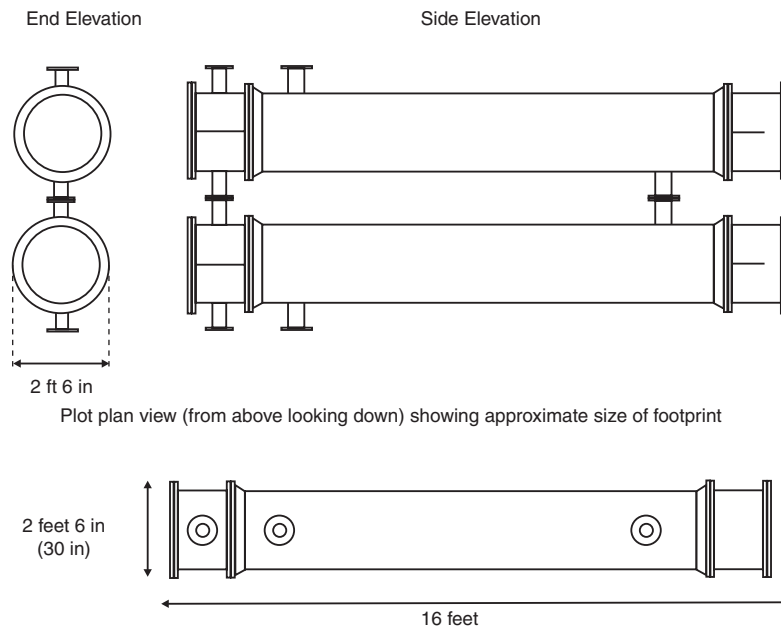

Figure E1.11 Approximate Dimensions and Footprint of Exchanger E-202

Table 1.11 Recommended Minimum Spacing (in Feet) between Process Equipment for Refinery, Chemical, and Petrochemical Plants

	Pumps	Compressors	Reactors	Towers and Vessels	Exchangers
Pumps	M	25	M	M	M
Compressors		M	30	M	M
Reactors			M	15	M
Towers				M	M
Exchangers					M

M = minimum for maintenance access

Source: *Process Plant Layout and Piping Design*, by E. Bausbacher and R. Hunt, © 1994, reprinted by permission of Pearson Education, Inc., Upper Saddle River, NJ

Next, the size of the major process lines must be determined. In order to estimate these pipe sizes, it is necessary to make use of some heuristics. A heuristic is a simple algorithm or hint that allows an approximate answer to be calculated. The preliminary design of a piece of equipment might well use many such heuristics, and some of these might conflict with each other. Like any simplifying procedure, the result from a heuristic must be reviewed carefully. For preliminary purposes, the heuristics from Chapter 11 can be used to estimate approximate pipe sizes. Example 1.12 illustrates the heuristic for calculating pipe size.

Example 1.12

Consider the suction line to P-202 A/B; what should be the pipe diameter?

From Table 11.8, 1(b) for liquid pump suction, the recommended liquid velocity and pipe diameter are related by $u = (1.3 + D \text{ (in)})/6$ ft/s.

From Table B.1.1, the mass flowrate of the stream entering P-202, $\dot{m} = \text{Stream 16} + \text{Stream 10} = 2170 + 5970 = 8140$ kg/h and the density is found to be 800 kg/m³.

The volumetric flowrate is $8140/800 = 10.2$ m³/h = 0.00283 m³/s = 0.0998 ft³/s.

The procedure is to calculate the velocity in the suction line and compare it to the heuristic. Using this approach, the following table is constructed:

Nominal Pipe Diameter (inch)	Velocity (ft/s) = Vol Flow/Flow Area	Velocity (h/s) from $u = (1.3 + D/6)$
1.0	18.30	1.47
1.5	8.13	1.55
2.0	4.58	1.63
3.0	2.03	1.80
4.0	1.14	1.97

Therefore, the pipe diameter that satisfies both the heuristic and the continuity equation lies between 3 and 4 in. Taking a conservative estimate, a 4-in suction line is chosen for P-202.

The next step to consider is the placement of equipment within the plot plan. This placement must be made considering the required access for maintenance of the equipment and also the initial installation. Although this step may seem elementary, there are many cases [5] where the incorrect placement of equipment subsequently led to considerable cost overruns and major problems both during the construction of the plant and during maintenance operations. Consider the example shown in Figure 1.10(a), where two vessels, a tower, and a heat exchanger are shown in the plot plan. Clearly, V-1 blocks the access to the exchanger's tube bundle, which often requires removal to change leaking tubes or to remove scale on the outside of the tubes. With this arrangement, the exchanger would have to be lifted up vertically and placed somewhere where there was enough clearance so that the tube bundle could be removed. However, the second vessel, V-2, and the tower T-1 are located such that crane access is severely limited and a very tall (and expensive) crane would be required. The relocation of these same pieces of equipment, as shown in Figure 1.10(b), alleviates both these problems. There are too many considerations of

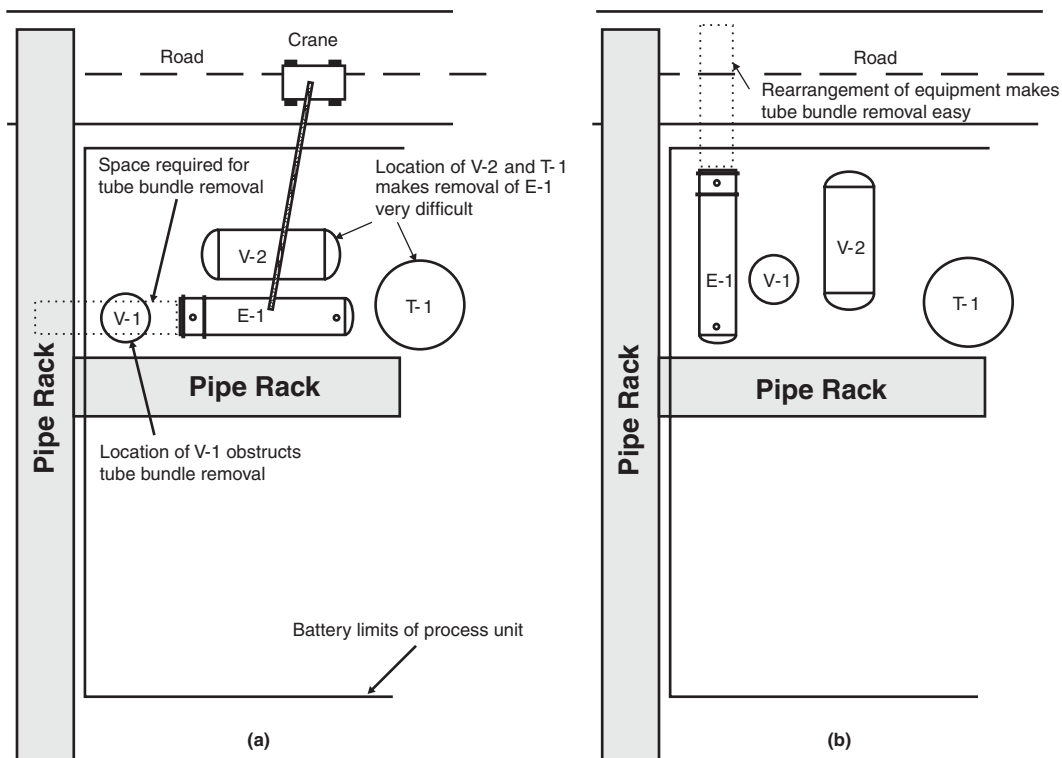

Figure 1.10 The Effect of Equipment Location on the Ease of Access for Maintenance, Installation, and Removal

this type to cover in detail in this text, and the reader is referred to Bausbacher and Hunt [5] for more in-depth coverage of these types of problems. Considering the DME facility, a possible arrangement for the feed and reactor subsection is shown in Figure 1.11.

3. *The elevation of all major equipment is established.* In general, equipment located at grade (ground) level is easier to access and maintain and is cheaper to install. However, there are circumstances that dictate that equipment be elevated in order to provide acceptable operation. For example, the bottoms product of a distillation column is a liquid at its bubble point. If this liquid is fed to a pump, then, as the pressure drops in the suction line due to friction, the liquid boils and causes the pumps to cavitate. To alleviate this problem, it is necessary to elevate the bottom of the column relative to the pump inlet, in order to increase the Net Positive Suction Head Available (for more detail about $NPSH_A$ see Chapter 21). This can be done by digging a pit below grade for the pump or by elevating the tower. Pump pits have a tendency to accumulate denser-than-air gases, and maintenance of equipment in such pits is dangerous due to the possibility of suffocation and poisoning (if the gas is poisonous). For this reason, towers are generally elevated between 3 and 5 m (10 and 15 ft) above ground level by using a "skirt." This is illustrated in Figure 1.12. Another reason for elevating a distillation column is also illustrated in Figure 1.12. Often a thermosiphon reboiler is used. These reboilers use the difference in density between the liquid fed to the reboiler and the two-phase mixture (saturated liquid-vapor) that leaves the reboiler

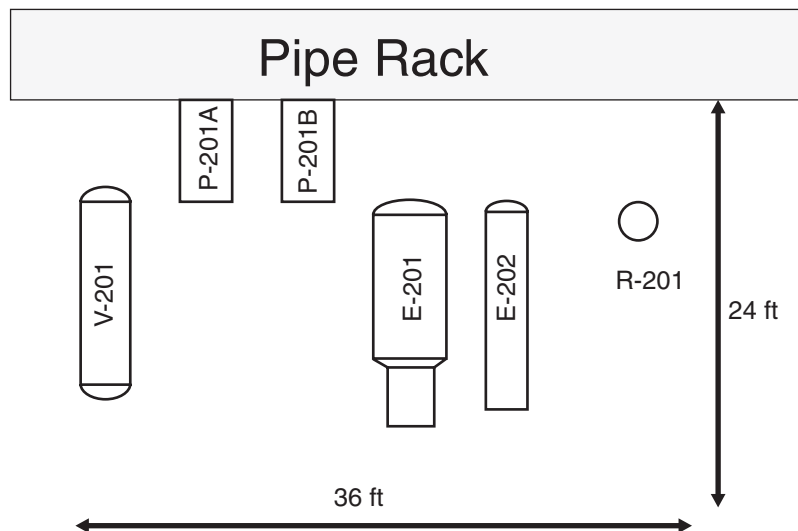

Figure 1.11 Possible Equipment Arrangement for the Reactor and Feed Section of DME Facility, Unit 200

to “drive” the circulation of bottoms liquid through the reboiler. In order to obtain an acceptable driving force for this circulation, the static head of the liquid must be substantial, and a 3–5 m height differential between the liquid level in the column and the liquid inlet to the reboiler is typically sufficient. Examples showing when equipment elevation is required are given in Table 1.12.

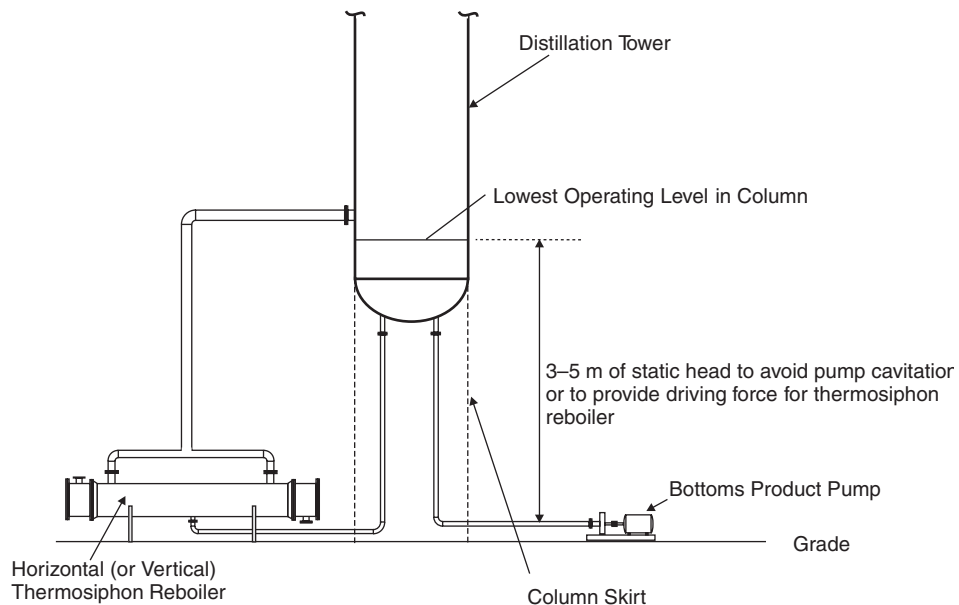

Figure 1.12 Sketch Illustrating Reasons for Elevating Distilling Column

Table 1.12 Reasons for Elevating Equipment

Equipment to Be Elevated	Reason for Elevation
Columns or vessels	When the NPSH available is too low to avoid cavitation in the discharge pump, equipment must be elevated.
Columns	To provide driving head for thermosiphon re-boilers.
Any equipment containing suspended solids or slurries	To provide gravity flow of liquids containing solids that avoids the use of problematic slurry pumps.
Contact barometric condensers	This equipment is used to produce vacuum by expanding high-pressure steam through an ejector. The condensables in the vapor are removed by direct contact with a cold-water spray. The tail pipe of such a condenser is sealed with a 34-foot leg of water.
Critical fire-water tank (or cooling water holding tank)	In some instances, flow of water is absolutely critical, for example, in firefighting or critical cooling operations. The main water supply tank for these operations may be elevated to provide enough water pressure to eliminate the need for feed pumps.

4. *Major process and utility piping are sketched in.* The final step in this preliminary plant layout is to sketch in where the major process (and utility) pipes (lines) go. Again, there are no set rules to do this. However, the most direct route between equipment that avoids clashes with other equipment and piping is usually desirable. It should be noted that utility lines originate and usually terminate in headers located on the pipe rack. When process piping must be run from one side of the process to another, it may be convenient to run the pipe on the pipe rack. All control valves, sampling ports, and major instrumentation must be located conveniently for the operators. This usually means that they should be located close to grade or a steel access platform. This is also true for equipment isolation valves.

1.6 THE 3-D PLANT MODEL

The best way to see how all the above elements fit together is to view the Virtual Plant Tour AVI file on the CD that accompanies this text. The quality and level of detail that 3-D software is capable of giving depend on the system used and the level of detailed engineering that is used to produce the model. Figures 1.13–1.15 were generated for the DME facility using the PDMS software package from Cadcentre, Inc. (These figures and the Virtual_Plant_Tour.AVI file are presented here with permission of Cadcentre, Inc.) In Figure 1.13, an isometric view of the DME facility is shown. All major process equipment, major process and utility piping, and basic steel structures are shown. The

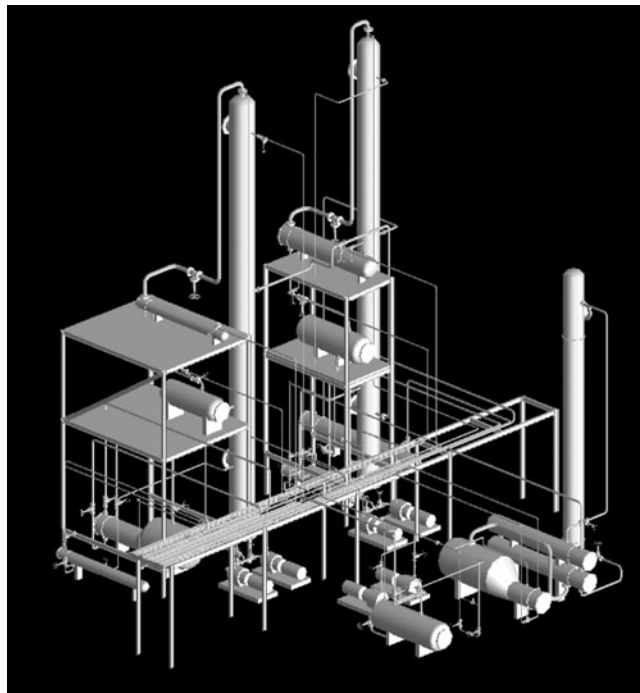

Figure 1.13 Isometric View of Preliminary 3-D Plant Layout Model for DME Process (Reproduced by Permission of Cadcentre, an Aveva Group Company, from their Vantage/PDMS Software)

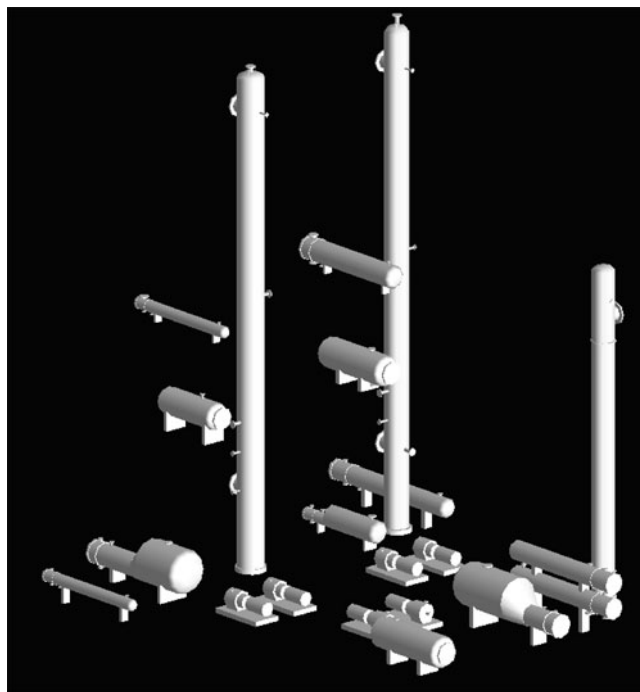

Figure 1.14 3-D Representation of Preliminary Equipment Layout for the DME Process (Reproduced by Permission of Cadcentre, an Aveva Group Company, from their Vantage/PDMS Software)

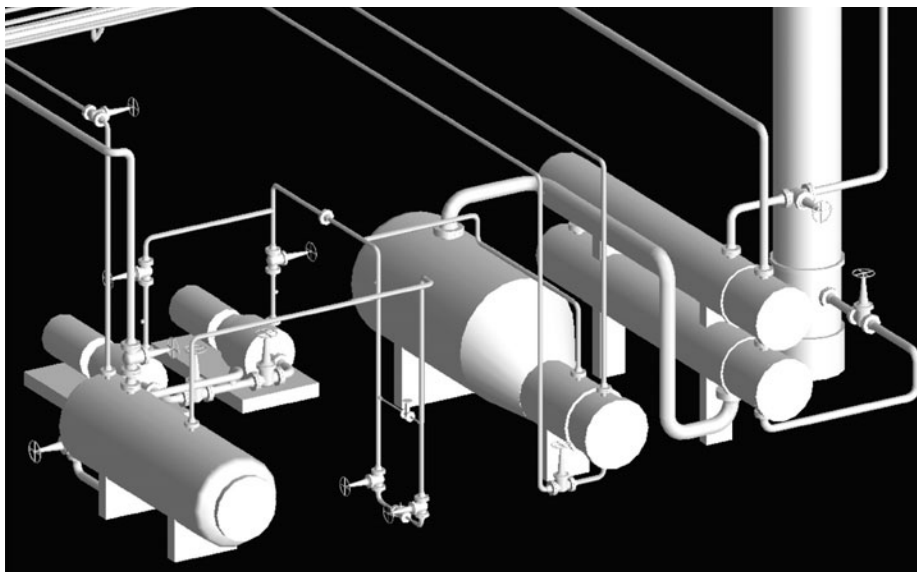

Figure 1.15 3-D Representation of the Reactor and Feed Sections of the DME Process Model (Reproduced by Permission of Cadcentre, an Aveva Group Company, from their Vantage/PDMS Software)

pipe rack is shown running through the center of the process, and steel platforms are shown where support of elevated process equipment is required. The distillation sections are shown to the rear of the figure on the far side of the pipe rack. The reactor and feed section is shown on the near side of the pipe rack. The elevation of the process equipment is better illustrated in Figure 1.14, where the piping and structural steel have been removed. The only elevated equipment apparent from this figure are the overhead condensers and reflux drums for the distillation columns. The overhead condensers are located vertically above their respective reflux drums to allow for the gravity flow of condensate from the exchangers to the drums. Figure 1.15 shows the arrangement of process equipment and piping for the feed and reactor sections. The layout of equipment corresponds to that shown in Figure 1.11. It should be noted that the control valve on the discharge of the methanol feed pumps is located close to grade level for easy access.

1.7 OPERATOR AND 3-D IMMERSIVE TRAINING SIMULATORS

1.7.1 Operator Training Simulators (OTS)

Up to this point in the chapter, the different elements and diagrams used in the specification and description of a process have been covered. The means by which the material balances, energy balances, and design calculations for the various unit operations, required to specify all the design conditions, have been carried out has not been covered. Indeed, the simulation of chemical processes using programs such as CHEMCAD, Aspen Plus, PRO/II, HYSIS, and others is not addressed until much later, in Chapter 13.

Nevertheless, it should be clear that extensive simulation of the process will be required to determine and to specify all of the conditions needed in the design. Typically, these simulations are carried out under steady-state conditions and represent a single design operating point, or possibly are made for several different operating points. The steady-state simulation of the process is clearly very important from the standpoint of defining the design conditions and specifying the equipment parameters, such as vessel sizes, heat-exchanger areas and duties, pipe sizes, and so on. However, once the plant has been built, started up, and commissioned, it is rare that the process will operate at that design condition for any given period of time. Moreover, how the process can be started up or run at, for example, 65% or 110% of design capacity is not evident from the original design. Nevertheless, the plant will be run at off-design conditions throughout its life. In order to help operators and engineers understand how to start up and shut down the process, deal with emergencies, or operate at off-design conditions, an operator training simulator (OTS) may be built.

The foundation of an OTS is a dynamic simulation (model) of the process to which a human machine interface (HMI) is connected. The HMI, in its simplest form, is a pictorial representation of the process that communicates with the dynamic model, and through it, process variables are displayed. The HMI also displays all the controls for the process; an operator can control the process by changing these controls. An example of an HMI is shown in Figure 1.16. This particular example shows a portion of an acid-gas recovery (AGR) unit for an OTS developed by the Department of Energy to simulate an IGCC (Integrated Gasification Combined Cycle) coal-fed power plant. Process variables calculated by the dynamic model are displayed in boxes throughout the HMI. Operators can monitor the change in these variables with time just as they would in a control room situation. The only difference is that the process is simulated rather than actually operating. In general terms, the OTS functions for an operator just as a flight simulator does for a pilot or astronaut. Therefore, operators and engineers can gain operational experience and understanding about a process or plant through the OTS but with the added benefit that any mistakes or errors can be identified and corrected during training sessions without exposing personnel to any risks that might occur if training were to be done on the actual plant.

The starting point for developing an OTS is the steady-state simulation, the equipment information, and instrumentation and control data. In general, the P&IDs are used as the starting point for the generation of the HMI since they contain all the necessary information for the controls and instrumentation. The dynamic model is developed so that the steady-state design condition will be simulated when all the inputs (feeds) are at their design values. Details of how dynamic simulators are used in process design are included in Chapter 17. Needless to say, the development of a fully functioning dynamic model for a process that accurately reflects all the controls and valves in the process is a substantial task that takes a team of engineers many months to accomplish.

1.7.2 3-D Immersive Training Simulators (ITS)

In Section 1.6, the concept of a 3-D plant model was introduced. Such models are “constructed” in an “electronic” environment using precise design data on the size, location and elevation (x -, y -, and z -coordinates), and orientation of each piece of equipment. In addition, the piping arrangement and location of valves, nozzles, instruments, sample ports, drains, and so forth are all specified. Such a representation allows the engineer and

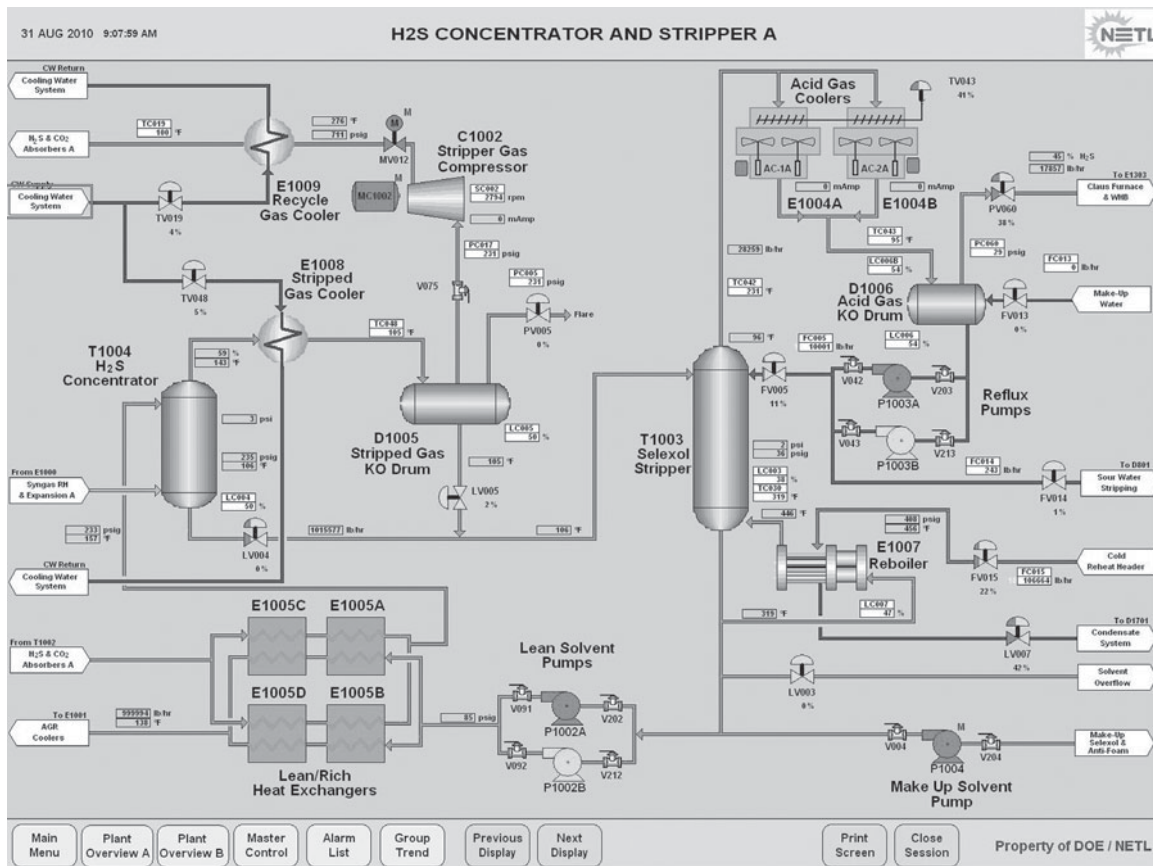

Figure 1.16 Example of an HMI Interface for an OTS (Reproduced by Permission of the DOE's National Energy Technical Laboratory and Invensys Systems Inc., Property and Copyright of Invensys plc, UK)

operator to evaluate the accessibility of critical process components and to obtain a feel for how the plant will look (and operate) when constructed. The engineer may access this information through either a 2-D viewer or a 3-D virtual environment (for example, using 3-D goggles). However, no matter how the information is viewed, the resulting images are essentially static and are generally of low to medium fidelity. Therefore, when viewing a 3-D plant model, it will always be clear to the viewer that it is just a model, and that the representation of the 3-D object is crude.

The visual enhancement of 3-D models using sophisticated imaging software and overlaying photorealistic images on top of a skeleton of the 3-D representation are now not only possible but commonplace for higher-end video games. Computer-generated graphics are now so advanced that, as any movie fan will attest, it is often difficult to determine what is "real" and what is animated. This technology is now being applied to develop 3-D immersive training simulators (ITS) for chemical plants. As can be seen from Figure 1.17, the quality and realism captured by computer-generated graphics are truly amazing. Furthermore, the use of avatars to represent plant operators makes it



Figure 1.17 An Example of a Computer-Generated Image of a Horizontal Drum (Reproduced by Permission of the DOE's National Energy Technical Laboratory and Invensys Systems Inc., Property and Copyright of Invensys plc, UK)

possible for a user to navigate through, interact with, and be truly immersed in the virtual plant.

1.7.3 Linking the ITS with an OTS

The potential for education and training of engineers, operators, and students using both the OTS and ITS appears to be limitless. Indeed, these two systems can be linked together such that they can communicate, and the real-time operation of the process, both in the control room and outside in the plant, can be simulated in the virtual environment. Consider the following scenario that might occur during the start-up of a chemical process:

Feed to a distillation column from an on-site storage drum has begun. The feed pump has been started and the flow through the pump has been confirmed from the HMI display in the control room. The liquid feed flows into the top of the tower, and the liquid levels on the distillation trays start to increase. The process appears to be working as described in the start-up manual that the operator is following. However, approximately 30 minutes after the start of the feed pumps, a low-level alarm sounds on the on-site storage drum. The operator monitors the level in the drum from the control room and determines that it is continuing to fall and will cause the feed pump to vapor lock (cavitate) if the situation is not remedied. In reviewing the start-up procedure, the operator determines that there is a remote function valve (one that cannot be operated remotely

from the control room) that connects the on-site storage drum to the off-site storage tank, and that this valve may have been closed inadvertently. She then contacts an operator in the field by walkie-talkie and asks him to check the status of the remote function valve. The field operator walks to the storage drum, identifies the tag name on the valve, and confirms that the valve is indeed closed. The control room operator then instructs the field operator to open the valve, which he does. The control room operator then confirms that the level in the drum has started to go back up and thanks the field operator for his help.

This scenario might well represent an actual incident during a scheduled plant start-up. However, this scenario could just as easily be simulated in the virtual environment. The control room operator would be sitting in front of the HMI screen that is connected to the OTS. A field operator could be sitting in the room next door with a walkie-talkie and wearing 3-D goggles connected to the ITS. The field operator would move his avatar to the location of the on-site storage drum and locate the remote function valve. The field operator using his avatar would then note the setting of the valve and after receiving instructions from the control room operator would open the valve. At this point, the ITS would communicate to the OTS that a valve had been opened, and this would then allow the flow of product to continue to the drum; that is, the dynamic model of the process would respond to the valve being opened and model the flow to the drum. The control room operator, monitoring the HMI, would see the result of the flow of product as an increase in the drum level.

Clearly, any number of scenarios involving control room operators and field operators could be implemented. Moreover, maintenance operations, safety training, and a whole host of other operator functions could be simulated—all in the virtual plant.

Augmented Reality. From the previous example it is clear that any feasible scenario that might occur in the actual plant can be simulated in the virtual environment. However, a series of cases can be simulated that would be almost impossible to simulate in the actual plant but are easily accomplished in virtual reality. For example, it might be helpful to show a young engineer how a particular piece of equipment works by showing him or her the details of the internals of that equipment. In the actual plant, this opportunity might not be available until a scheduled plant shutdown occurs, and that might not happen for one or two years. However, in the virtual environment, the operation of a given piece of equipment can be easily displayed. In fact, the avatar can move into the plant and simply “strip away” the outer wall of a piece of equipment and look inside to see what is happening. This additional feature is sometimes referred to as augmented reality (AR). As an example of AR, the operation of a reboiler and a distillation column is illustrated in Figures 1.18(a) and 1.18(b), respectively.

Another example of AR is the display of process data in the virtual plant. For example, if an operator wanted to check on the trend of a certain process variable, say, the temperature in a reactor, or look at a schematic of a pump, the avatar can simply click on a piece of equipment and display that trend, as shown in Figure 1.19. Clearly, in the virtual environment, there are very few limitations on what information the operator (avatar) can access.

Training for Emergencies, Safety, and Maintenance. The possibilities for training operators and engineers in the virtual plant environment are unlimited. Of particular importance are the areas of safety, emergency response, and routine maintenance. For example, the response of an operator or team of operators to an emergency situation can be

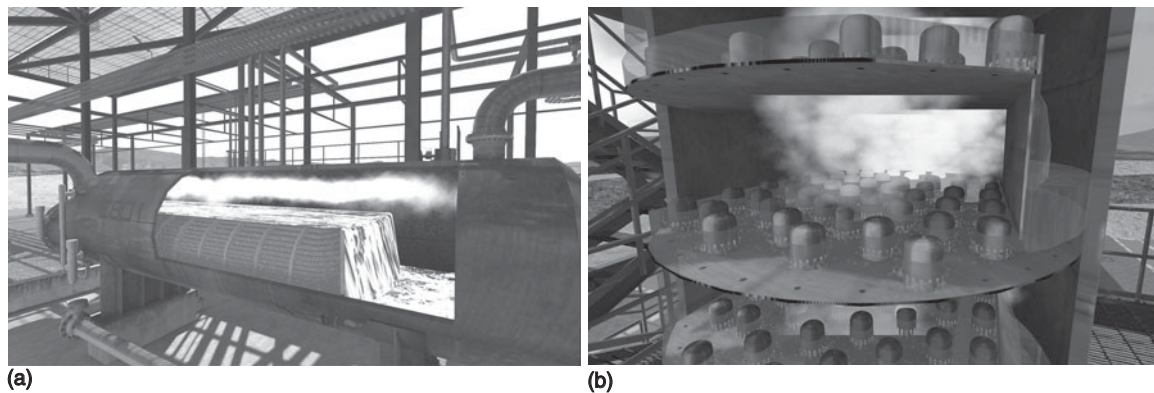

Figure 1.18 Augmented Reality in ITS: (a) Reboiler (b) Bubble-Cap Distillation Column (Reproduced by Permission of the DOE's National Energy Technical Laboratory and Invensys Systems Inc., Property and Copyright of Invensys plc, UK)

monitored, recorded, and played back in the virtual plant. Any mistakes made by the operator(s) can be analyzed, feedback given, and then the exercise can be repeated until the correct response is achieved. Although such training does not absolutely guarantee that when a real emergency arises in the plant the operators will respond correctly, it nevertheless provides crucial emergency training under realistic conditions without the



Figure 1.19 An Avatar Can Access Process Trends and Observe Equipment Schematics in AR (Reproduced by Permission of Invensys Systems Inc., Property and Copyright of Invensys plc, UK)

fear of actual harm to personnel and equipment. Furthermore, the more often such scenarios are rehearsed, the more likely are operators to respond correctly when real emergencies occur in the plant.

Corresponding scenarios for safety and maintenance training can also be implemented. Often these activities must follow well-defined procedures, and again, the virtual environment offers a perfect venue to record, analyze, and provide feedback to personnel as they perform these various tasks.

In summary, the use of the virtual plant environment (ITS linked to an OTS) provides unlimited opportunities to a new generation of engineers and operators to learn and to train as process plant personnel and to hone their respective skills in an environment that is both realistic and safe.

1.8 SUMMARY

In this chapter, you have learned that the three principal types of diagrams used to describe the flow of chemical streams through a process are the block flow diagram (BFD), the process flow diagram (PFD), and the piping and instrumentation diagram (P&ID). These diagrams describe a process in increasing detail.

Each diagram serves a different purpose. The block flow diagram is useful in conceptualizing a process or a number of processes in a large complex. Little stream information is given, but a clear overview of the process is presented. The process flow diagram contains all the necessary information to complete material and energy balances on the process. In addition, important information such as stream pressures, equipment sizes, and major control loops is included. Finally, the piping and instrumentation diagram contains all the process information necessary for the construction of the plant. These data include pipe sizes and the location of all instrumentation for both the process and utility streams.

In addition to the three diagrams, there are a number of other diagrams used in the construction and engineering phase of a project. However, these diagrams contain little additional information about the process.

The logic for equipment placement and layout within the process was presented. The reasons for elevating equipment and providing access were discussed, and a 3-D representation of a DME plant was presented. The concept of operator training simulators is presented and the role of 3-D immersive training systems is also introduced.

The PFD is the single most important diagram for the chemical or process engineer and will form the basis of much of the discussion covered in this book.

WHAT YOU SHOULD HAVE LEARNED

- The difference between and uses of the block flow diagram, the process flow diagram, the piping and instrumentation diagram, plot plans, elevation diagrams, and piping isometrics
- A method for drawing consistent process flow diagrams
- How operator training systems and 3-D graphic process representations are used to train operators and engineers

REFERENCES

1. Kauffman, D., "Flow Sheets and Diagrams," *AICHE Modular Instruction, Series G: Design of Equipment*, series editor J. Beckman, American Institute of Chemical Engineers, New York, 1986, Vol. 1, Chapter G.1.5. Reproduced by permission of the American Institute of Chemical Engineers, AIChE copyright © 1986, all rights reserved.
2. *Graphical Symbols for Process Flow Diagrams*, ASA Y32.11 (New York: American Society of Mechanical Engineers, 1961).
3. Austin, D. G., *Chemical Engineering Drawing Symbols* (London: George Godwin, 1979).
4. *Instrument Symbols and Identification*, Research Triangle Park, NC: Instrument Society of America, Standard ISA-S5-1, 1975.
5. Bausbacher, E., and R. Hunt, *Process Plant Layout and Piping Design* (Upper Saddle River, NJ: Prentice Hall PTR, 1998).

SHORT ANSWER QUESTIONS

1. What are the three principal types of diagrams used by process engineers to describe the flow of chemicals in a process? On which of these diagrams would you expect to see the following items?
 - a. The temperature and pressure of a process stream
 - b. An overview of a multiple-unit process
 - c. A major control loop
 - d. A pressure indicator
 - e. A pressure-relief valve
2. A problem has occurred in the measuring element of a level-indicating controller in a batch reactor. To what principal diagram should you refer in order to troubleshoot the problem?
3. Why is it important for a process engineer to be able to review a three-dimensional model (actual or virtual/electronic) of the plant prior to the construction phase of a project?
4. Name five things that would affect the locations of different pieces of equipment when determining the layout of equipment in a process unit.
5. Why are accurate plant models (made of plastic parts) no longer made as part of the design process? What function did these models play and how is this function now achieved?
6. In the context of process modeling tools, what do OTS and ITS stand for?
7. What is augmented reality? Give one example of it.

PROBLEMS

8. There are two common reasons for elevating the bottom of a tower by means of a "skirt." One reason is to provide enough $NPSH_A$ for bottoms product pumps to avoid cavitation. What is the other reason?

9. Which of the principal diagrams should be used to do the following:
 - a. Determine the number of trays in a distillation column?
 - b. Determine the top and bottom temperatures in a distillation column?
 - c. Validate the overall material balance for a process?
 - d. Check the instrumentation for a given piece of equipment in a “pre-start-up” review?
 - e. Determine the overall material balance for a whole chemical plant?
10. What is the purpose(s) of a pipe rack in a chemical process?
11. When would a structure-mounted vertical plant layout arrangement be preferred over a grade-mounted, horizontal, in-line arrangement?
12. A process that is being considered for construction has been through several technical reviews; block flow, process flow, and piping and instrumentation diagrams are available for the process. Explain the changes that would have to be made to the three principal diagrams if during a final preconstruction review, the following changes were made:
 - a. The efficiency of a fired heater had been specified incorrectly as 92% instead of 82%.
 - b. A waste process stream flowrate (sent to a sludge pond) was calculated incorrectly and is now 30% greater than before.
 - c. It has been decided to add a second (backup) drive for an existing compressor.
 - d. The locations of several control valves have changed to allow for better operator access.
13. During a retrofit of an existing process, a vessel used to supply the feed pump to a batch reactor has been replaced because of excessive corrosion. The vessel is essentially identical to the original one, except it is now grounded differently to reduce the corrosion. If the function of the vessel (namely, to supply liquid to a pump) has not changed, answer the following questions:
 - a. Should the new vessel have a new equipment number, or should the old vessel number be used again? Explain your answer.
 - b. On which diagram or diagrams (BFD, PFD, or P&ID) should the change in the grounding setup be noted?
14. Draw a section of a P&ID diagram for a vessel receiving a process liquid through an insulated 4-in schedule-40 pipe. The purpose of the vessel is to store approximately 5 minutes of liquid volume and to provide “capacity” for a feed pump connected to the bottom of the pump using a 6-in schedule-40 pipe. The diagram should include the following features:
 - a. The vessel is numbered V-1402 and the pump(s) are P-1407 A/B.
 - b. The discharge side of the pump is made of 4-in schedule-40 carbon steel pipe and all pipe is insulated.
 - c. A control valve is located in the discharge line of the pump, and a double block and bleed arrangement is used (see Problem 1.15 for more information).
 - d. Both pumps and vessel have isolation (gate) valves.
 - e. The pumps should be equipped with drain lines that discharge to a chemical sewer.
 - f. The vessel is equipped with local pressure and temperature indicators.
 - g. The vessel has a pressure-relief valve set to 50 psig that discharges to a flare system.
 - h. The tank has a drain valve and a sampling valve, both of which are connected to the tank through separate 2-in schedule-40 CS lines.

- i. The tank level is used to control the flow of liquid out of the tank by adjusting the setting of the control valve on the discharge side of the pump. The instrumentation is similar to that shown for V-104 in Figure 1.7.
15. A standard method for instrumenting a control valve is termed the “double block and bleed,” which is illustrated in Figure P1.15.

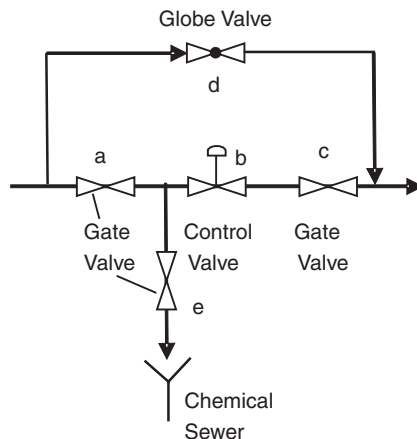
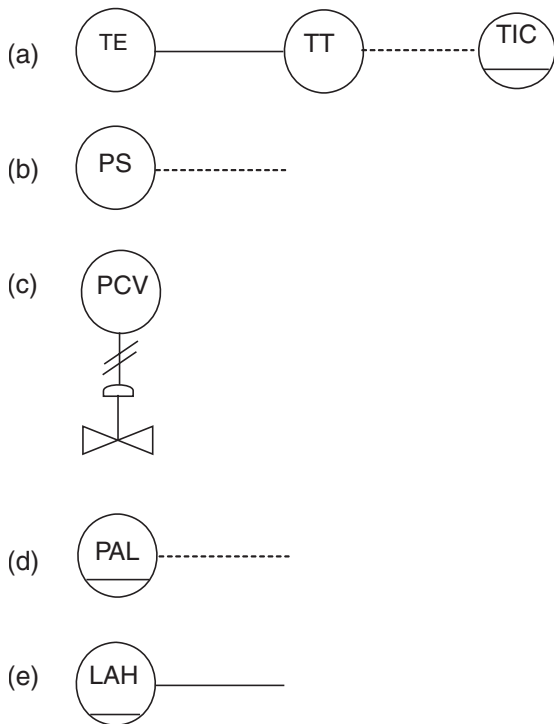

Figure P1.15 Double Block and Bleed Arrangement for Problem 1.15

- Under normal conditions, valves a to c are open and valves d and e are closed. Answer the following:
- Explain, carefully, the sequence of opening and closing valves required in order to change out the valve stem on the control valve (valve b).
 - What changes, if any, would you make to Figure P1.15 if the process stream did not contain a process chemical but contained process water?
 - It has been suggested that the bypass valve (valve d) be replaced with another gate valve to save money. Gate valves are cheap but essentially function as on-off valves. What do you recommend?
 - What would be the consequence of eliminating the bypass valve (valve d)?
16. Often, during the distillation of liquid mixtures, some noncondensable gases are dissolved in the feed to the tower. These noncondensables come out of solution when heated in the tower and may accumulate in the overhead reflux drum. In order for the column to operate satisfactorily, these vapors must be periodically vented to a flare or stack. One method to achieve this venting process is to implement a control scheme in which a process control valve is placed on the vent line from the reflux drum. A pressure signal from the drum is used to trigger the opening or closing of the vent line valve. Sketch the basic control loop needed for this venting process on a process flow diagram representing the top portion of the tower.
17. Repeat Problem 1.16, but create the sketch as a P&ID to show all the instrumentation needed for this control loop.

18. Explain how each of the following statements might affect the layout of process equipment:
- A specific pump requires a large NPSH.
 - The flow of liquid from an overhead condenser to the reflux drum is gravity driven.
 - Pumps and control valves should be located for easy access and maintenance.
 - Shell-and-tube exchangers may require periodic cleaning and tube bundle replacement.
 - Pipes located at ground level present a tripping hazard.
 - The prevailing wind is nearly always from the west.
19. Estimate the footprint for a shell-and-tube heat exchanger from the following design data:
- Area = 145 m²
 - Hot side temperatures: in at 300°C, out at 195°C
 - Cold side temperature: bfw at 105°C mps at 184°C
 - Use 12 ft, 1-in OD tubes on a 1 1/4-in square pitch, use a single shell-and-tube pass because of change of phase on shell side
 - Use a vapor space above boiling liquid = 3 times liquid volume
20. Make a sketch of a layout (plot plan only) of a process unit containing the following process equipment:
- 3 reactors (vertical—diameter 1.3 m each)
 - 2 towers (1.3 and 2.1 m in diameter, respectively)
 - 4 pumps (each mounting pad is 1 m by 1.8 m)
 - 4 exchangers (footprints of 4 m by 1 m, 3.5 m by 1.2 m, 3 m by 0.5 m, and 3.5 m by 1.1 m)
- The two columns and the three reactors should all be aligned with suitable spacing and all the exchangers should have clearance for tube bundle removal.
21. Using the data from Table 1.7, estimate the footprints of all the equipment in the toluene HDA process.
- For the shell-and-tube exchangers, assume 12 ft, 1.25 in tubes on a 1.5 in square pitch, and assume 2 ft additional length at either end of the exchanger for tube return and feed header.
 - For double pipe exchangers, assume an 8-in schedule-20 OD and a 6-in schedule-40 ID pipe with a length of 12 ft including u-bend.
 - For the footprints of pumps, compressors, and fired heater, assume the following:
 - P-101 use 2 m by 1 m, P-102 use 2 m by 1 m
 - C-101 (+D-101) use 4 m by 2 m
 - H-101 use 5 m by 5 m
22. With the information from Problem 1.21 and the topology given in Figure 1.5, accurately sketch a plant layout (plot plan) of the toluene HDA process using a grade-mounted, horizontal, in-line arrangement similar to the one shown in Figure 1.9. You should assume that the area of land available for this process unit is surrounded on three sides by an access road and that a pipe rack runs along the fourth side. Use the information in Table 1.11 as a guide to placing equipment.

23. What do the following symbols (as seen on a P&ID) indicate?



24. Determine all the errors in the section of a P&ID shown in Figure P1.24.

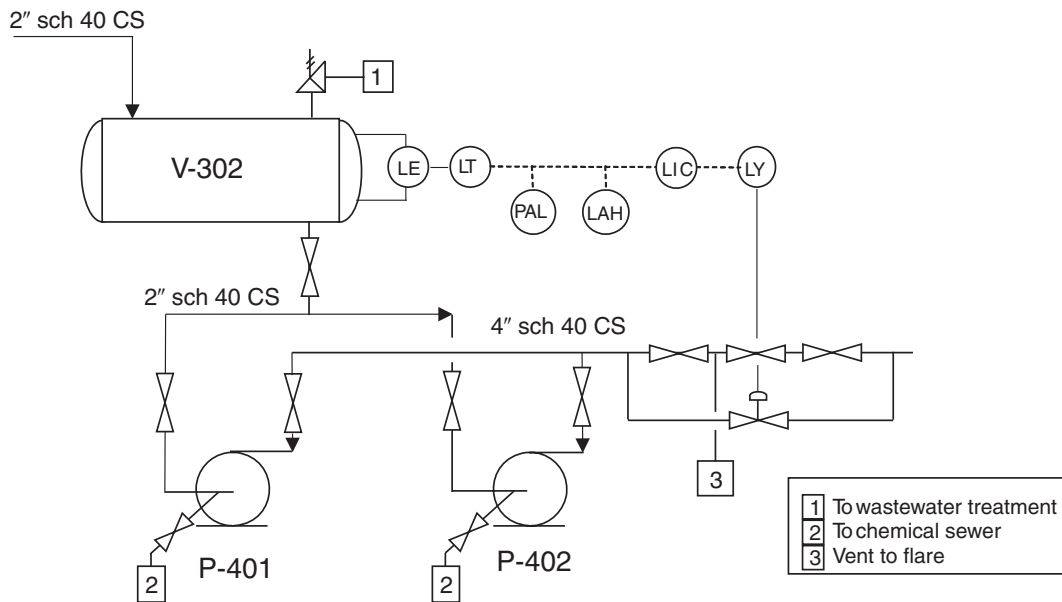

Figure P1.24 A Section of a P&ID to Be Used in Problem 1.24

Index

Numbers

- 3-D (three dimensions)
 - CAD program representing plant in, 27
 - plant model in, 35–37
 - representation of processes in, 27–28

A

- ABET,
 - engineer-in-training certification, 875
- Absorbers
 - selecting equipment parameters, 399
 - troubleshooting packed-bed absorber, 827
- Absorption approach, to recycling
 - unreacted raw materials, 66–67
- Accelerated successive substitution (or relaxation) methods, in steady-state simulation, 569–570
- Accident statistics, in risk assessment, 886–887
- Accuracy, in capital cost estimation, 166–167
- ACGIH (American Conference of Governmental and Industrial Hygienists), air contaminants standards, 890
- Acid-gas removal (AGR)
 - flowsheet showing use of chilled methanol, 563, 572, 575, 579
 - flowsheet showing use of purge stream and splitter block, 584
- ACM. See Aspen Custom Modeler (ACM)
- Acrylic acid product, troubleshooting off-specification product, 831–833
- Activated sludge, in waste treatment, 379
- Activation energy, in Arrhenius equation, 790
- Activity-coefficient models
 - hybrid systems, 411
 - LLE, 409
 - overview of, 405
 - solids, 430
 - strategy for choosing, 409–410
 - types of phase equilibrium models, 407–410
 - VLE, 408, 587–589
- Actual interest rate, 240
- Adams-Bashford method, 621–622
- Adams-Moulton method, 621–622
- Adiabatic mixer, tracing chemical pathways, 125–126
- Adiabatic reactor, equipment-dependent and equipment-independent relationships, 689–690
- Adiabatic splitter, tracing chemical pathways, 125–126
- Advanced process control (APC), 669–670

- AES. See Aspen Engineering Suite (AES)
- Agencies, health and safety. See Regulations/agencies
- AICHE. See American Institute of Chemical Engineers (AIChE)
- Air contaminants standards (OSHA and NIOSH), 890
- Alcohol fuel, coal to, 6–7
- Aluminum (and it alloys), material selection, 186
- American Chemical Society, codes of conduct, 872–873
- American Chemistry Council, Responsible Care program, 898
- American Conference of Governmental and Industrial Hygienists (ACGIH), air contaminants standards, 890
- American Institute of Chemical Engineers (AIChE)
 - business codes of conduct, 880
 - codes of ethics, 863
 - Dow Fire & Explosion Index, 907
 - Guidelines for Technical Management of Chemical Process Safety*, 893
 - HSE rules and regulations, 888
 - loss control credit factors, 908–909
- American National Standards Institute (ANSI), format for MSDSs, 890–891
- American Petroleum Institute, Recommended Practices, 893
- American Society of Mechanical Engineers (ASME), set of symbols of, 9
- American units, diagram options for, 27
- AND gate, in FTA and FMEA analyses, 901
- Annuity, calculating with cash flow diagrams, 246–247
- ANSI (American National Standards Institute), format for MSDSs, 890–891
- Aqueous electrolyte system, building simulator model for, 423–429
- AR (Augmented reality), 41–42
- ASME (American Society of Mechanical Engineers), set of symbols of, 9
- Aspen+. See Aspen Custom Modeler (ACM)
- Aspen Custom Modeler (ACM)
 - applying to tear stream convergence, 572–573, 575–576
 - applying to tear stream selection, 567
 - applying to user flash model, 556–558
 - comparing decision variables, 585–586
 - comparing simulator solutions, 580
 - data regression system of, 588
 - programs for creating user-added models, 553
- Aspen Engineering Suite (AES)
 - dynamic simulation examples, 626–629

- dynamic simulation of flash separators and storage vessels, 615–616
 - dynamic simulation of heat exchanger, 613–614
 - integrator methods, 624
- Attenuation, in inherently safe design, 910
 - Augmented reality (AR), 41–42
 - Auto-ignition temperature, 898
 - Auxiliary facilities costs, in estimating bare module costs, 193
 - Azeotropic distillation
 - in binary systems, 368–370
 - overview of, 367–368
 - in ternary systems, 370–377
- ## B
- BACT (best available control technology), in green engineering, 922
 - Bare module equipment costs
 - algorithm for calculating, 191–193
 - at base conditions, 177–181
 - CAPCOST program for calculating, 196–198
 - by list of equipment types, 1028–1033
 - at non-base conditions, 181–185
 - Base case
 - scope of, 458
 - selecting in optimization, 457–458
 - Base-case ratios
 - in analysis of pump ability to handle scale up, 697–698
 - applying to steam release problem, 835
 - in case study replacing cumene catalyst, 804
 - heating loops and, 764
 - predicting process change with, 696
 - relative to equipment size, physical properties, and steam properties, 697
 - Base costs, analyzing, 459–460
 - Batch operations, batch process compared with, 50
 - Batch optimization
 - optimum cycle time for batch processes, 484–487
 - overview of, 479
 - scheduling equipment for batch processes, 479–484
 - Batch processes
 - deciding to use continuous or batch processes, 50–54, 74
 - defined, 50–54
 - design calculations for, 87
 - designing distillation columns and, 398
 - equipment design for multiproduct processes, 107–109

- Batch processes (*continued*)
 flowshop plants and, 97–99
 Gantt charts and scheduling, 93–94
 hybrid batch/continuous process option, 77–78
 intermediate storage, 104–106
 jobshop plants and, 99–102
 nonoverlapping operations, overlapping operations, and cycle times, 94–97
 optimum cycle time for, 484–487
 overview of, 87
 parallel process units, 106–107
 product design and, 123
 product storage for single-product campaigns, 102–104
 review questions and problems, 110–113
 scheduling equipment for, 479–484
 steps in, 88–93
 summary and references, 109–110
- Batch reactors, selecting equipment parameters in PFD synthesis, 396–397
- Batch sequencing, 87
- BCF (biconcentration factor), properties impacting environment fate of chemicals, 915
- Benchmarks
 for acceptable rate of return, 282
 in optimization, 458
- Benzene. See also Toluene HDA process
 block flow process diagram for production of, 6
 distillation of benzene from toluene, 754
 distillation process, 23, 26
 flow summary table for benzene process, 14
 input/output models in production of, 690–691
 primary flow paths in toluene HDA process, 127–129
 producing via hydrodeallylation of toluene, 17–19
 replacing catalytic reactor in benzene process, 800–804
 utility costs in production via toluene HDA process, 228–229
- Best available control technology (BACT), in green engineering, 922
- BFDs. See Block flow diagrams (BFDs)
- Bfw (boiler feed water)
 energy balance with steam side, 763
 regulating utility streams in chemical plants, 663–664
- Biconcentration factor (BCF), properties impacting environment fate of chemicals, 918
- Binary distillation
 azeotropic distillation, 368–370
 breaking using intermediate boiling component, 375
 control case studies, 672–676
 McCabe-Thiele and, 369–370
- Binary interaction parameters (BIPs)
 gathering physical property data for PFD design, 360
 phase equilibrium and, 405–406
- Blast wave, in explosions, 899
- Blenders
 bare module factors in costs, 1033
 cost curves for purchased equipment, 1016
 cost equation for purchased equipment costs, 1005
- BLEVE (boiling-liquid expanding-vapor explosions), 899
- Block flow diagrams (BFDs)
 benzene distillation stages, 26
 coal to alcohol fuel, 6–7
 as intermediate step between process concept and PFD, 57–60
 Kauffman on, 4
 overview of, 5
 plant diagram, 6–8
 process diagram, 5–6
 synthesizing PFD from. See Synthesis of PFD, from BFD
- Blocks, unsupported blocks in dynamic simulation, 606–607
- Blowers
 bare module factors in costs, 1028, 1030
 heuristics for, 347
- Boil-up rate, debottlenecking strategies for reboiler, 758
- Boiler feed water (bfw)
 energy balance with steam side, 763
 regulating utility streams in chemical plants, 663–664
- Boilers
 debottlenecking strategies for reboiler, 758
 distillation columns requiring reboiler, 754
 performance curves for, 709
 reboiler performance impacting distillation column performance, 756–757
 regulating utility streams in chemical plants, 663–664
 steam boilers, 220
 waste heat boilers, 223
- Boiling-liquid expanding-vapor explosions (BLEVE), 899
- Boiling point, properties impacting environment fate of chemicals, 918
- Book value, depreciation and, 255
- Bottlenecks. See also Debottlenecking
 distillation columns, 758–759
 heating loops, 764–765
- Bottom-up strategies, in process optimization, 455–456
- Boundaries, on residue curves, 376
- Boundary value design method (BVDM)
 conceptualization of distillation sequences, 377
 for ternary azeotropic distillation, 370–371, 374
- Brainstorming
 optimization and, 453
 as problem-solving strategy, 821–823
- Broyden's method
 applied to tear stream convergence, 571, 574
 comparing approaches to tear convergence, 579–580
 for steady-state simulation, 571
- By-products (unwanted)
 DIPB example, 807–808
 eliminating, 462–463
 of reactions, 787
 reducing in green engineering, 921
 separator design and, 364
- Bypass streams
 identifying in toluene HDA process, 132–135
 tracing chemical species in flow loops, 132
- C**
- C programming language, in creating user-added models, 553
- CAD (Computer aided design)
 for 3-D representation, 27
 applying to immersive training simulators, 39
- Calculator blocks, in process simulation, 562
- Capacity (unit capacity)
 economies of scale, 169–171
 equation for, 167
 equipment cost attribute, 168
- CAPCOST program
 bare module factors in equipment costs, 1028–1033
 calculating plant costs, 196–198
 cost curves for purchased equipment, 1009–1020
 cost equation for purchased equipment costs, 1005–1008
 material factors in equipment cost, 1025–1027
 Monte Carlo Simulation (M-C) used with, 310
 overview of purchased equipment costs, 1003–1004
 pressure factors in costs, 1021–1024
 references, 1034
- Capital cost estimation
 accuracy and options in, 166–167
 algorithm for calculating bare module costs, 191–193
 bare module equipment costs at base conditions, 177–181
 bare module equipment costs at non-base conditions, 181–185
 capacity impacting purchased equipment costs, 167–171
 CAPCOST for calculating bare module costs, 196–198
 classification of cost estimates, 164–165
 equipment costs, 167
 grassroots vs. total module costs, 193–195
 highest expected cost range example, 166
 Lang Factor method, 176–177
 lowest expected cost range, 165–166
 materials of construction (MOCs) and, 186–191
 module costing technique, 177
 overview of, 161, 163
 plant costs, 172–176

- retrofitting evaluated with, 292
- review questions and problems, 199–202
- summary and references, 198–199
- time impacting purchased equipment costs, 171–172
- Capital costs, defined, 163
- Capitalized cost factor, 284
- Capitalized cost method, 284
- Carbon steel, selection of materials of construction, 186
- Carnot efficiency, refrigeration and, 215–216
- Cascade control system
 - advantages/disadvantages of, 654
 - example controlling product purity in distillation column, 654–655
- Cash flow, after tax, 260–261
- Cash flow diagrams (CFDs)
 - annuity calculation using, 246–247
 - calculations using, 245–246
 - cumulative cash flow diagram, 244–245
 - discount factors and, 247–250
 - discrete cash flow diagram, 242–244
 - overview of, 241–242
 - profitability analysis for new project, 269–271
- Catalysts
 - adding to feed, 61
 - case study replacing cumene catalyst, 804–808
 - filtering from reaction vessel, 90
 - gathering reaction kinetic data for PFD design, 358–359
 - mass transfer and, 808
 - methods for avoiding reactor hot spots, 797
 - reaction rate and, 788–789
 - reactor design and, 360–361
- Catalytic reactors, case study replacing, 800–804
- Cause analysis, in troubleshooting strategy, 820, 823–824
- Cavitation, NPSH and, 724
- CCP (cumulative cash position), in project evaluation, 271–272
- CCR (cumulative cash ratio), in project evaluation, 272
- Ceiling concentration, OSHA standard for chemical exposure limits, 890
- Centers for Engineering, Ethics and Society, 871
- Centrifugal compressors, performance curves, 727–728
- Centrifugal pumps, performance curves, 714–717
- Centrifuges
 - bare module factors in costs, 1033
 - cost curves for purchased equipment, 1016
 - cost equation for purchased equipment, 1005
- CEPCI (Chemical Engineering Plant Cost Index). See Chemical Engineering Plant Cost Index (CEPCI)
- CFDs. See Cash flow diagrams (CFDs)
- CFR (Code of Federal Regulations)
 - federal rules for health, safety, and environment, 888–889
 - legal liability and, 879
- Chapman-Enskog formulation, in thermodynamics, 555
- Charter, for group formation, 941
- Checklists
 - P&IDs as plant checklist, 25
 - in Process Hazard Analysis requirement, 901
- Chemical components, selecting for PFD synthesis, 389–390
- Chemical components, tracing in PFD
 - creating written process description, 137
 - guidelines and tactics, 125–126
 - limitations in, 135–137
 - nonreacting chemicals and, 135
 - primary paths, 126–132
 - recycle and bypass streams, 132–135
 - review problems, 137–138
 - summary, 137
- Chemical Engineering Plant Cost Index (CEPCI)
 - CAPCOST program, 196
 - inflationary trends in capital costs over time, 171–172
 - values 1996 to 2011, 173
- Chemical Engineering Principles and Practices exam. See Principles and Practice (PE) exam
- Chemical engineers
 - ethics and professionalism. See Ethics/professionalism
 - interactions among, 358
 - interpersonal and communication skills of, 929–930
 - role in risk assessment, 888
 - teamwork and. See Teams
 - uses of P&IDs by, 25
- Chemical equilibrium, in modeling electrolyte systems. See also Equilibrium, 420
- Chemical hazards. See Hazards; Health, safety, and environment (HSE)
- Chemical process diagrams. See also Graphical representations
 - 3-D plant model, 35–37
 - additional diagram types, 26–27
 - block flow diagrams. See Block flow diagrams (BFDs)
 - immersive training simulators (ITS), 38–40
 - linking ITS with OTS systems, 40–43
 - operator training simulators (OTS), 37–38
 - overview of, 3–5
 - pipng and instrumentation diagrams. See Piping and instrumentation diagrams (P&ID)
 - plant layout based on information in PFD, 28–35
 - process concept diagrams, 54–55
 - process flow diagrams (PFDs). See Process flow diagrams (PFDs)
 - review questions and problems, 44–48
 - summary and references, 43–44
 - three-dimensional representation of processes, 27–28
- Chemical process industry (CPI), scope and products of, 3
- Chemical processes. See Processes
- Chemical product design
 - batch processing, 123
 - economics of, 123
 - generation of ideas for, 119–120
 - manufacturing process, 122
 - overview of, 115–116
 - product need and, 117–119
 - selection process, 120–122
 - strategies for, 116–117
 - summary and references, 123–124
- Chemical reactions
 - case study of acetone production, 809–812
 - catalytic reactions, 808
 - chemicals required but not consumed, 56
 - distillation of reaction products in batch processes, 90–92
 - endothermic. See Endothermic reactions
 - excess reactants affecting recycle structure, 71
 - exothermic. See Exothermic reactions
 - gathering kinetic data for PFD design, 358–359
 - heat supply/removal and, 750, 786
 - heat transfer, 796
 - inert materials in controlling, 61–62
 - ionic reactions, 437
 - pressure impact on, 695–696, 792
 - process concept diagram in identification of, 54–55
 - rate of. See Reaction rate
 - reaction kinetics, 154, 785, 787
 - reaction vessels, 88–90
 - reactor design, 361
 - reasons for operating at conditions of special concern, 143, 146
 - resource materials for, 79
 - runaway reactions, 797, 899–900
 - temperature impact on, 752–753
- Chemical reactors. See Reactors
- Chemical Safety and Hazard Investigation Board, 909
- Chemicals, fate of chemicals in environment, 916–919
- Chillers. See Coolers
- Classification
 - of cost estimates, 164–165
 - of process analysis, 688
- Clean Air Act (CAA)
 - air contaminants standards, 890
- Chemical Safety and Hazard Investigation Board created by, 909
 - as EPA regulation, 895
 - focus on employee health, 885
 - incidence rate for illness and injury, 886
 - legal liability and, 879–880
- Occupational Safety and Health Administration Act of 1970, 889
- Process Safety Management Regulation of 1992, 893–894
- Risk Management Plan (RMP), 896
- summary of environmental laws, 917

- Clean Water Act (CWA)
EPA regulations, 895
summary of environmental laws, 917
- Closed-cup method, for measuring flash point, 899
- Coal
BFD for coal to alcohol fuel, 6–7
utility costs and, 210
- Coast Guard, regulating transport of hazardous chemicals, 896
- Code of Federal Regulations (CFR)
federal rules for health, safety, and environment, 888–889
legal liability and, 879
- Codes of conduct
American Chemical Society, 872–873
for businesses, 880–881
- Codes of ethics
American Institute of Chemical Engineers (AIChE), 863–865
National Society of Professional Engineers (NSPE), 866–867
resource materials for, 871
- Cohen-Coon tuning rule, in dynamic simulation solutions, 626, 627–629
- Colburn equation, for continuous differential separations (packed beds), 730–732
- Colburn graph, applied to troubleshooting packed bed absorbers, 826
- Cold zones, in endothermic reactions, 797
- COM (Cost of manufacturing). See Manufacturing cost estimation
- Combined feedback/feed-forward system advantages/disadvantages of, 653–654
example cooling a process stream in a heat exchanger, 654
- Combustion. See also Fires and explosions defined, 898
reducing in green engineering, 921
- Commercial software. See Software
- Commodity chemicals, 115
- Common Denominator Method, evaluating profitability based on equipment operating life, 287–288
- COMPLEX algorithm, in NLP optimization study, 582
- Component database, simulator features, 386
- Composition, measurement of process variables, 649
- Compound interest
continuously compounded, 241
time basis in calculating, 240
types of interest, 238–239
- Comprehensive Environmental Response, Compensation, and Liability Act (CERCLA)
overview of, 896
retroactive liability in, 924
summary of environmental laws, 917
- Compressors
bare module factors in costs of, 1028, 1030
cost curves for purchased equipment, 1009
cost equation for purchased equipment costs, 1005
heuristics for, 347
performance curves, 727–728
pressure factors in costs of, 1022
reasons for operating at conditions of special concern, 146
refrigeration and, 216–217
selecting equipment parameters in PFD synthesis, 395
specifying fluid type and conditions, 660
- Computer aided design (CAD)
for 3-D representation, 27
applying to 3-D immersive training simulators, 39
- Concentration control, reasons for multiple reactors, 71
- Concept scoring, selection process in chemical product design, 121–122
- Concept screening, selection process in chemical product design, 120–121
- Condensers, impact on performance of distillation columns, 757–758
- Conditions of special concern
analysis and justification, 150–151
evaluation of reactors, 151–156
for operation of equipment other than reactors and separators, 146–150
pressure limits, 140
reasons for operating at, 141–142
temperature limits, 141–142
- Confined spaces, regulation regarding workers in, 894
- Conservation equations, applied to equipment geometry and size, 607–608
- Constant of equal percentage valves, in flowrate control, 645–646
- Constraints
defined, 452
including in equipment performance analysis, 740
optima calculated along, 454
optimization studies and, 583
pinch technology and, 499
VLE and, 587
- Containment, in inherently safe design, 910
- Contingency costs, in estimating bare module costs, 193
- Continuous processes
compared with PFT reactors, 791–796
considerations in deciding to use continuous or batch processes, 50–54, 74
defined, 50
hybrid batch/continuous process option, 77–78
- Continuous stirred-tank reactors (CSTRs)
dynamic models for, 616–617
as hypothetical system, 792–793
methods for avoiding reactor hot spots, 797, 799
performance equation for, 791–792
reactor models and, 793–794
selecting equipment parameters in PFD synthesis, 396
series of, 617
- Control loops
dynamic simulation and, 624–626
information regarding in PFDs, 8
P&IDs and, 25
PFD synthesis and, 379
- Control systems
cascade control system, 654–655
challenges of dynamic simulation, 603
combining feedback and feed-forward systems, 653–654
feed-forward control system, 651–653
feedback control system, 649–651
in inherently safe design, 910
logic control system, 666–669
performance problems and, 684
ratio control system, 655–657
split-range control system, 657–660
- Controllability, considerations in deciding to use continuous or batch processes, 53
- Controlled variable (CV)
process control in dynamic simulation, 625
split-range control system and, 657
- Controlling/regulating chemical processes
adjusting heat transfer coefficient for heat exchangers, 666
advanced process control (APC), 669
binary distillation case studies, 672–676
cascade control system, 654–655
combining feedback and feed-forward systems, 653–654
control strategies, 649
cumene reactor case study, 671–672
exchanging heat between process streams and utilities, 662–665
feed-forward control system, 651–653
feedback control system, 649–651
flowrate and pressure regulation, 646–648, 660–662
logic control system, 666–669
measurement of process variables, 649
model-based control, 670
operator training simulators (OTS) and, 676–677
overview of, 641–642
ratio control system, 655–657
regulating temperature driving force between process fluid and utility, 665–666
review questions and problems, 678–682
simple regulation problem, 642–643
split-range control system, 657–660
statistical process control (SPC), 669–670
summary and references, 677–678
valve regulation, 643–646
- Controlling resistances, in system analysis, 698–700
- Conventions
for drawing P&ID diagrams, 22
for identifying instrumentation on P&ID diagrams, 24
for identifying process equipment in PFDs, 12

- Convergence criteria, selecting for PFD simulation, 400–401
- Conversion, of reactants
 example of effect of temperature and pressure on, 792
 single-pass and overall, 65–66, 787–788
 thermodynamic limitations on, 790–791
- Conveyors
 bare module factors in costs, 1033
 cost curves for purchased equipment, 1017
 cost equation for purchased equipment costs, 1005
- Coolers
 in acid-gas removal, 563, 572, 575, 579
 dynamic simulation and, 609–612
 performance curves for coolant system, 721
 for product chemicals in batch processes, 92–93
 solids modeling and, 432
- Cooling process streams
 combined feedback/feed-forward system, 654
 feed-forward control system, 651–653
- Cooling water facility (tower)
 estimating utility costs, 211–215
 utilities provided off-site, 212
- Cooling water, regulating utility streams, 662–663
- Coordination, of group effort, 934
- Copper (and it alloys), selection of materials of construction, 186
- Cost curves, for purchased equipment
 for blenders and centrifuges, 1016
 for compressors and drives, 1009
 for conveyors and crystallizers, 1017
 for dryers and dust collectors, 1018
 for evaporators and vaporizers, 1010
 for fans, pumps, and power recovery equipment, 1011
 for filters and mixers, 1019
 for fired heaters and furnaces, 1012
 for heat exchangers, 1013
 for packing, trays, and demisters, 1014
 for reactors and screens, 1020
 for storage tanks and process vessels, 1015
- Cost equation, for purchased equipment
 explanation of factors in equation, 1004
 list of equipment types with descriptions and cost factors, 1005–1008
- Cost indexes, in tracking inflation, 250
- Cost of manufacturing (COM). See Manufacturing cost estimation
- CPI (chemical process industry), scope and products of, 3
- CPM (Critical path method), group scheduling and, 942
- Critical constants, simulation of, 390
- Critical path method (CPM), group scheduling and, 942
- Crystallization
 of product chemicals in batch processes, 92–93
 solid-liquid equilibrium (SLE) and, 429
- Crystallizers
 bare module factors in costs, 1033
 cost curves for purchased equipment, 1017
 cost equation for purchased equipment costs, 1005
 flowsheet for p-Xylene crystallizer, 432–433
- CSTRs. See Continuous stirred-tank reactors (CSTRs)
- Cumene
 controlling/regulating chemical processes, 671–672
 increasing conversion in cumene reactor, 753
 replacing catalyst in cumene reactor, 804–808
 temperature increase impacting reaction rate, 752–753
 temperature profiles for cumene reactor, 751–752
 troubleshooting entire process, 836–840
 troubleshooting process feed section, 829–831
 troubleshooting steam release, 833–835
- Cumulative cash flow diagram, 244–245
- Cumulative cash position (CCP), in project evaluation, 271–272
- Cumulative cash ratio (CCR), in project evaluation, 272
- Cumulative distribution function, 303–305
- Cumulative Sum (CUSUM) charts, in statistical process control, 670
- CV (Controlled variable)
 process control in dynamic simulation, 625
 split-range control system and, 657
- Cycle times
 batch process sequence, 96–97
 in flowshop plants, 98–99
- D**
- DAEs. See Differential algebraic equations (DAEs)
- Data
 collection and synthesis stage of process flow diagram, 78
 dynamic, 608–609
- Data output generator, simulator features, 387
- Databanks, physical properties in simulators, 390
- Databases, component database in simulation, 386
- DCFROR. See Discounted cash flow rate of return (DCFROR)
- DCS (distributed control system), 676
- DDB (Double declining balance depreciation method), 255–256, 261
- Debottlenecking
 distillation columns, 758–759
 heating loop, 840
 removing obstacles to process changes, 820
 types of problems, 684, 821
- Decide phase, in troubleshooting strategy, 824
- Decision variables
 flowsheet optimization using, 473–477
 identifying and prioritizing, 460–461
 objective function modeled in terms of, 476–477
 objective function sensitivity to changes in, 476
 optimal values from SM and EO methods, 585
 overview of, 452
 in parametric optimization, 467–468
 sensitivity studies and, 583
- Define phase, in troubleshooting strategy, 824
- Definitive (Project Control) estimate, classification of cost estimates, 164–165
- Deflagration explosions, 899
- DEM (dominant eigenvalue method), for steady-state simulation, 570
- Demand
 in chemical markets, 295–298
 considerations in deciding to use continuous or batch processes, 52
- Demisters
 bare module factors in costs, 1028, 1032
 cost curves for purchased equipment, 1014
- Density
 physical properties related to thermodynamics, 404
 simulation of, 390
- Department of Energy (DOE), in HSE regulation, 885
- Department of Transportation (DOT)
 in HSE regulation, 885
 legal liability and, 879
 transport of hazardous chemicals and, 896
- Depreciation
 after tax profit and, 260–261
 of capital investment, 253–254
 in evaluation of new project and, 270
 example calculating, 254–256
 modified accelerated cost recovery system (MACRS), 258–259
 types of, 254–256
- Design
 calculations, for batch processes, 87
 process design. See Process design
 product design. See Product design
 role of experience in, 332
 societal impact of chemical engineering design, 853–855
 types of problems, 821
- Design blocks, in process simulation, 562
- Detailed (Firm or Contractor) estimate, classification of cost estimates, 164–165
- Detonation explosions, 899
- Deviation, HAZOP, 902
- Diagnostic/troubleshooting problem, types of performance problems, 684

- Diagrams, of chemical processes. See Chemical process diagrams
- Differential algebraic equations (DAEs)
 - converting ODEs to, 619
 - dynamic models and, 618
 - implicit methods in approach to, 620
- Diffusion coefficient, in modeling electrolyte systems, 421–422
- Direct manufacturing costs
 - example of calculating, 207
 - multiplication factors in estimating, 206
 - overview of, 203–205
- Direct substitution
 - applied to tear stream convergence, 571, 574
 - steady-state simulation algorithms, 569
- Directed graphs, flowsheet represented by, 563
- Discount factors, cash flow diagrams and, 247–250
- Discounted cash flow rate of return (DCFROR)
 - CAPCOST program using, 310
 - computing, 280–281
 - interest rate-related criteria in project evaluation, 277–278
 - in profitability analysis, 162
 - sensitivity analysis for quantifying risk, 300
 - when to use in comparing investments, 279
- Discounted criteria, in evaluation of profitability, 275–279
- Discounted cumulative cash position, 275–277
- Discounted payback period (DPBP)
 - sensitivity analysis for quantifying risk, 300
 - time-related criteria in project evaluation, 275
- Discrete cash flow diagram, 242–244
- Discretionary money, 234
- Display options, for simulation output, 400
- Distillation
 - approaches to recycling unreacted raw materials, 67
 - azeotropic, generally, 367–368
 - azeotropic in binary systems, 368–370
 - azeotropic in ternary systems, 370–377
 - of benzene, 23, 26
 - binary distillation case studies, 672–676
 - gathering physical property data for PFD design, 359–360
 - key performance relationships, 694
 - performance curves, 733–740
 - of reaction products in batch processes, 90–92
 - simple, 364–367
 - tactics for tracing chemical species and, 127
 - towers, 350, 352
- Distillation columns
 - bottlenecks and debottlenecking strategies, 758–759
 - building model for electrolyte system, 437–440
 - building model for sour-water stripper (SWS), 426–428
 - condenser impacting performance of, 757–758
 - control schemes for, 672–676
 - controlling product purity in, 654–655
 - designing, 397–398
 - dynamic models for, 617–618
 - input/output model for, 687–688
 - optimization example, 468–469
 - performance of multiple unit operations, 754–755
 - reboiler impacting performance of, 756–757
 - scaling down flows in, 755
 - selecting equipment parameters in PFD synthesis, 397
- Distributed control system (DCS), 676
- Disturbance variables (DVs)
 - challenges of dynamic simulation, 603
 - defined, 601
- Disturbed-parameter models, for heat exchangers, 609
- DMC (dynamic matrix control), types of model-based controls, 670
- DMO solver, in Aspen+, 586
- Dominant eigenvalue method (DEM), for steady-state simulation, 570
- Double declining balance depreciation method (DDB), 255–256, 261
- Dow Chemical Hazards Index, 909
- Dow Fire & Explosion Index (F&EI), 906–909
- DPBP (Discounted payback period)
 - sensitivity analysis for quantifying risk, 300
 - time-related criteria in project evaluation, 275
- Drainage and spill control, in Dow Fire & Explosion Index, 906
- Drives
 - bare module factors in costs, 1028, 1030
 - cost curves for purchased equipment, 1009
 - pressure factors in costs of, 1022
- Drums, heuristics for. See also Vessels, 344
- Dryers
 - bare module factors in costs, 1033
 - cost curves for purchased equipment, 1018
 - cost equation for purchased equipment costs, 1005
- Dust collectors
 - bare module factors in costs, 1033
 - cost curves for purchased equipment, 1018
 - cost equation for purchased equipment costs, 1006
- Duties and obligations, ethical problem solving, 862
- DVs (disturbance variables)
 - challenges of dynamic simulation, 603
 - defined, 601
- Dynamic data, dynamic simulation and, 608–609
- Dynamic matrix control (DMC), types of model-based controls, 670
- Dynamic simulators
 - conservation equations applied to equipment geometry and size, 607–608
- DAEs (differential algebraic equations)
 - options, 619
 - distillation columns and, 617–618
 - dynamic data and dynamic specifications in, 608–609
 - examples, 626–632
 - flash separators and storage vessels and, 614–616
 - heat exchangers and, 609, 612–614
 - heaters/coolers and, 609–612
 - initialization step in solution methods, 618–619
 - integrator methods, 620–624
 - making topological changes to steady-state simulation, 603–607
 - method of lines, 617
 - need for, 602–603
 - overview of, 601–602
 - process control loops, 624–626
 - reactors and, 616–617
 - review questions and problems, 633–639
 - setting up, 603
 - solution methods, 618
 - stiff problems and, 619–620
 - summary and references, 632–633
- Dynamic specifications, in dynamic simulators, 608–609
- ## E
- EAOC. See Equivalent annual operating costs (EAOC)
- ECO (Equivalent capitalized cost), evaluating profitability of equipment, 285
- Economics
 - analyzing profitability. See Profitability analysis
 - of chemical processes, 161–162
 - engineering and time value of money. See Engineering economic analysis
 - estimating capital costs. See Capital cost estimation
 - estimating manufacturing costs. See Manufacturing cost estimation
 - of operating at increased pressure when dealing with gases, 140
 - PFDs in economic analysis, 139
 - of pollution prevention, 923–924
 - of product design, 123
- Economies of scale
 - considerations in deciding to use continuous or batch processes, 51
 - equipment capacity and, 169–170
- EDR (Exchanger Design and Rating), 613–614
- Effective annual interest rate, 240–241
- Effectiveness factor (F), applied to shell-and-tube exchangers, 520–526

- Efficiency
 considerations in deciding to use continuous or batch processes, 52
 group synergy and, 932
- EIS (environmental impact statement), 895
- EIT (Engineer-in-training) certification, 875–878
- Electricity, utilities provided off-site, 212
- Electrochemical processes, 416
- Electrolyte systems modeling
 building model for aqueous electrolyte system, 423–429
 building model of distillation column, 437–440
 chemical equilibrium in, 420
 diffusion coefficient in, 421–422
 Gibbs energy calculation for, 434–437
 heat capacity in, 419–420
 molar volume in, 420
 overview of, 416–419
 surface tension in, 422–423
 thermal conductivity in, 421
 viscosity in, 420–421
- Elevation diagrams, types of auxiliary diagrams used, 27
- Elevation of equipment, establishing, 33–35
- Emergencies, simulation in training for, 41–43
- Emergency Planning and Community Right to Know Act (EPCRA) of 1986
 emergency release of emissions and, 895–896
 summary of environmental laws, 917
- Emissions
 emergency release of, 895–896
 fugitive, 895
 planned, 894–895
 reducing, 921–922
- Employees, OSHA focus on safety and health of, 885
- Endothermic reactions
 in acetone production case study, 809–812
 cold zones in, 797
 heat supply necessary for reaction, 786
 heat transfer and, 796
 reactor design and, 361
- Energy, process energy recovery system, 78
- Engineer-in-training (EIT) certification, 875–878
- Engineering economic analysis
 annuity calculation, 246–247
 calculations using cash flow diagrams, 245–246
 cash flow diagrams in, 241–242
 compound interest and, 238–239
 cumulative cash flow diagram, 244–245
 depreciation of capital investments, 253–254
 discount factors using with cash flow diagrams, 247–250
 discrete cash flow diagram, 242–244
 fixed capital and working capital, 254
 inflation, 250–252
 interest rates changing over time, 239
- investments and time value of money, 234–237
 modified accelerated cost recovery system (MACRS), 258–259
 overview of, 162, 233–234
 review questions and problems, 263–268
 simple interest and, 238
 summary and references, 261–262
 taxation, cash flow, and profit, 259–261
 time basis in calculating compound interest, 240–241
 types of depreciation, 254–258
- Engineering ethics
 overview of, 856
 at TAMU, 871
- Enthalpy
 composite enthalpy curves for estimating heat-exchanger surface area, 517–520
 composite enthalpy curves for systems without a pinch, 516
 composite temperature-enthalpy diagram, 514–516
 MESH (material balance, phase equilibrium, summation equations, and enthalpy balance), 423–424
 model, 404
- Environment. See also Health, safety, and environment (HSE)
 fate of chemicals in, 916–919
 life-cycle analysis (LCA) of product consequences, 924–925
 PFD analyzed in terms of environmental performance, 922–923
 PFD synthesis and, 378–379
 release of waste to, 916
- Environmental control block, in block flow diagram, 59
- Environmental impact statement (EIS), 895
- Environmental Protection Agency (EPA)
 definition of worst-case release, 887–888
 emergency release of emissions, 895–896
 focus of, 885
 legal liability and, 879
 overview of, 894
 planned emissions, 894–895
 Risk Management Plan (RMP), 896–897
 web-based resources for green engineering, 915
- Environmental regulations
 green engineering and, 915–916
 laws related to, 917
 need for steady-state simulation, 552
 reasons for not operating at design conditions, 707
- EO. See Equation-oriented (EO) approach
- EOS. See Equations of state (EOS)
- EPA. See Environmental Protection Agency (EPA)
- Equal percentage valves, in flowrate control, 645
- Equation-oriented (EO) approach
 applied to optimization studies, 583–586
 applied to sensitivity studies, 581
 comparing approaches to tear convergence, 579–580
- to linear/nonlinear equations, 622
- SMod approach as hybrid of SM and EO, 578
- to steady-state simulation, 576–578
- Equations
 approach to linear/nonlinear, 622
 for use in trend analysis, 694
- Equations of state (EOS)
 electrolyte models and, 417
 hybrid systems, 411
 types of phase equilibrium models, 405–406
- VLE constraints and, 587–589
- Equilibrium
 inert materials added to feed for controlling reactions, 62
- LLE. See Liquid-Liquid equilibrium (LLE)
- MERSHQ (material balance, energy balance, rate equations, hydraulic equations, and equilibrium equations) in, 424
- MESH (material balance, phase equilibrium, summation equations, and enthalpy balance) in, 423–424
- multistage separations, 728–729
- phase equilibrium. See Phase equilibrium
- reactor design and, 360–361
- reasons for multiple reactors, 71
- SLE. See Solid-liquid equilibrium (SLE)
- unwanted product or inerts impacting, 72
- VLE. See Vapor-Liquid equilibrium (VLE)
- Equilibrium conversion, reasons for operating at conditions of special concern, 142–143
- Equilibrium, of market forces (market equilibrium), 295–298
- Equilibrium reactors, selecting equipment parameters in PFD synthesis, 396
- Equipment
 base-case ratios applied to sizing, 697
 CAPCOST program for purchased equipment costs, 1003–1004
 conditions of special concern in operation of, 146–150
 conservation equations applied to geometry and size of, 607–608
 conventions used in drawing P&IDs, 22
 cost evaluation of new project and, 270–271
 descriptions for PFDs and P&IDs, 16
 designing for multiproduct processes, 107–109
 duplicate or parallel process units, 106–107
 effect of purchased equipment on capacity, 167–171
 effect of time on costs of purchased equipment, 171–172
 elevation of, 33–35
 eliminating in optimization process, 463–464

- Equipment (*continued*)
- equipment-dependent and equipment-independent relationships, 689–690
 - estimating cost of purchased equipment, 167
 - evaluating profitability of equipment with different operating lives, 284–288
 - evaluating profitability of equipment with same operating lives, 283–284
 - fixed characteristics imposing constraints on day to day operations, 685
 - identifying in PFD process topology, 9, 11–12
 - information regarding in PFDs, 8
 - input/output models, 687–688
 - placement of, 32–33
 - plant layout options, 28, 30
 - pressure range tolerances, 140
 - rearranging in optimization process, 464–466
 - reasons for not operating at design conditions, 707–708
 - recommended distances for spacing between, 28, 31
 - scheduling for batch processes, 479–484
 - selecting equipment parameters in PFD synthesis, 393–400
 - summarizing in PFD, 16–18
 - understanding behavior as key to troubleshooting, 822
- Equipment cost attribute, capacity and, 168
- Equipment fouling, in decision to use continuous or batch processes, 53
- Equipment summary table, PFD synthesis and, 380
- Equivalent annual operating costs (EAOC)
- analyzing base costs in optimization process, 459
 - evaluating profitability of equipment, 286–287
 - evaluating retrofitting with, 293
 - of exchanger network, 526–527
 - in profitability analysis, 162
- Equivalent capitalized cost (ECO), evaluating profitability of equipment, 285
- Ethanol, pervaporation for purifying, 369–370
- Ethical dilemmas, 870
- Ethical heuristics, 870–871
- Ethics/professionalism
- business codes of conduct, 880–881
 - codes of ethics, 863–867
 - engineer-in-training certification, 875–878
 - ethical dilemmas, 870
 - ethical heuristics, 870–871
 - legal liability, 879–880
 - mobile truth, 859–861
 - moral autonomy, 857
 - nonprofessional responsibilities, 861–862
 - overview of, 855
 - Principles and Practice (PE) exam, 878–879
 - professional registration (certification), 874–875
 - reasons for ethical behavior, 856
 - reflection in action, 858–859
 - rehearsal of new skills, 857–858
 - resource materials for, 871–874
 - review questions and problems, 882–884
 - summary and references, 881–882
 - whistle-blowing, 865, 868–870
- Euler method
- as numerical integrator method, 620
 - predictor-corrector methods and, 621
- Evaluate phase, in troubleshooting strategy, 824
- Evaporators
- bare module factors in costs, 1028, 1030–1031
 - cost curves for purchased equipment, 1010
 - cost equation for purchased equipment costs, 1006
 - pressure factors in costs of, 1022
- Excel, in creating user-added models, 553
- Exchanger Design and Rating (EDR), 613–614
- Exchanger networks
- determining EAOC of, 526–527
 - network design based on pinch points, 499
- Exothermic reactions
- heat reduction, 749–750
 - heat removal necessary for reaction, 786
 - heat transfer in, 796
 - hot spots in, 796–797
 - inert materials added to feed for controlling, 61–62
 - reactor design and, 361
 - runaway reactions, 899–900
- Experience-based principles, in process design
- advantages/disadvantages of materials of construction, 342
 - applying heuristics and guidelines, 335–338
 - heuristics and shortcut methods, 332–333
 - heuristics for compressors, fans, blowers, and vacuum pumps, 347
 - heuristics for drivers and power recovery equipment, 343
 - heuristics for drums (process vessels), 344
 - heuristics for heat exchangers, 348
 - heuristics for liquid-liquid extraction, 353
 - heuristics for packed towers (distillation and gas absorption), 352
 - heuristics for piping, 346
 - heuristics for pressure and storage vessels, 345
 - heuristics for pumps, 346
 - heuristics for reactors, 354
 - heuristics for refrigeration and utility specifications, 355
 - heuristics for thermal insulation, 349
 - heuristics for towers (distillation and gas absorption), 350
 - maximizing benefits of experience, 333–335
 - overview of, 331–332
 - physical property heuristics, 340
 - process unit capacities, 341
 - review questions and problems, 356
 - role of experience in design process, 332
 - summary and references, 338–339
- Expert systems, simulator features, 391
- Explicit methods, numerical integrator methods, 620
- Explosions. See also Fires and explosions, 899
- F**
- F* (effectiveness factor), applied to shell-and-tube exchangers, 520–526
- F&EI (Dow Fire & Explosion Index), 906–909
- Failure mode and effects analysis (FMEA), in Process Hazard Analysis requirement, 901
- Falsified data, morality of, 857–858
- Fans
- bare module factors in costs, 1028, 1031–1032
 - cost curves for purchased equipment, 1011
 - cost equation for purchased equipment costs, 1006
 - heuristics for, 347
 - pressure factors in costs of, 1022
- Fatal accident rate (FAR), 886–888
- Fault diagnosis and identification (FDI), uses of dynamic simulation, 603
- Fault-tree analysis (FTA), in Process Hazard Analysis requirement, 901
- FBD (Function Block Diagram), types logic controls, 667
- FCC (fluidized catalytic cracking), of solids, 429
- FCI. See Fixed Capital Investment (FCI)
- FE (Fundamentals of Engineering) exam, 875–878
- Feasible point, in NLP optimization study, 581–582
- Federal government, regulations for HSE, 888–889
- Federal Insecticide, Fungicide, and Rodenticide Act (FIFRA), 917
- Federal Register (FR), 888–889
- Feed chemicals/feed streams
- additions required for stabilization or separation, 61
 - additions required generally, 75
 - alternatives for use in green engineering, 919
 - considerations relating to purifying the feed, 60–61
 - debottlenecking strategies for reboiler, 759
 - evaluating process conditions for reactors, 154–156
 - identifying using process concept diagram, 54–55
 - inert materials for controlling equilibrium reactions, 61–62

- performance of multiple unit operations, 765–767
- preparing for reactor and separator, 377–378
- reactors transforming into products, 127
- reasons for non-stoichiometric feed composition of special concern, 145
- reasons for not operating at design conditions, 707
- recycling together with product, 67–70
- reducing feed rate, 767–768
- selecting feed stream properties in PFD synthesis, 393
- troubleshooting cumene process feed section, 829–831
- troubleshooting cumene reactor, 839
- Feed-forward control system
 - advantages/disadvantages of, 651
 - combining feedback control system with, 653–654
 - cooling a process stream in a heat exchanger, 651–653
 - process simulation and, 562
- Feedback control system
 - advantages/disadvantages of, 649
 - applying to DME production, 650–651
 - combining feed-forward control system with, 653–654
 - flowrate and, 646
 - for material balance in cumene reactor, 672
- Fees, in estimating bare module costs, 193
- Ferrous alloys, selection of materials of construction, 186
- Fiduciary responsibilities, business codes of conduct, 880
- FIFRA (Federal Insecticide, Fungicide, and Rodenticide Act), 917
- Film heat transfer coefficients, 512, 517
- Filters
 - bare module factors in costs, 1033
 - cost curves for purchased equipment, 1019
 - cost equation for purchased equipment costs, 1006
 - for water used in steam production, 218–219
- Fired heaters
 - bare module factors in costs, 1028, 1032
 - cost curves for purchased equipment, 1012
 - selecting equipment parameters in PFD synthesis, 395
- Fires and explosions
 - Dow Fire & Explosion Index, 906–909
 - overview of, 898–900
 - pressure-relief systems and, 900
- Fixed Capital Investment (FCI)
 - depreciation of, 254
 - evaluation of new project and, 270–271
 - in formula for cost of manufacturing, 205
- Fixed manufacturing costs
 - calculating, 207
 - overview of, 204–206
- Fixing problems, steps in process troubleshooting, 820
- Flares, in pressure-relief systems, 900
- Flash point, of liquid, 899
- Flash separators, dynamic simulation and, 614–616
- Flash units, selecting equipment parameters in PFD synthesis, 397
- Flash vessel
 - conservation equations applied to geometry and size of, 608
 - dynamic simulation of, 615–616
 - pressure-flow and, 604–606
- Flexibility
 - deciding to use continuous or batch processes, 51
 - optimization related to, 479
 - process flexibility, 708
- Flow diagrams
 - block flow diagrams. See Block flow diagrams (BFDs)
 - pipng and instrumentation diagrams. See Piping and instrumentation diagrams (P&ID)
 - process flow diagrams. See Process flow diagrams (PFDs)
 - value in communication of information, 3
- Flow loops, tactics for tracing chemical species, 132
- Flow summary table, PFD synthesis and, 379–380
- Flowrates
 - of centrifugal compressors, 728
 - determining maximum flow rate for Dowtherm A, 761–765
 - measurement of process variables, 649
 - performance curves for, 718–719
 - pressure and, 644, 660–662
 - reasons for not operating at design conditions, 707
 - regulating, 646–648, 660–662, 720–723
 - troubleshooting packed-bed absorber, 827
 - valves controlling, 641–646
- Flowsheet builder, simulator features, 387
- Flowsheet solver, simulator features, 387
- Flowsheets
 - of chilled methanol in acid-gas removal, 563, 572, 575, 579
 - degrees of freedom in optimization of, 583
 - for gasifier, 559
 - optimization using decision variables, 473–477
 - of purge stream and splitter block in acid-gas removal, 584
 - selecting topology for PFD synthesis, 392–393
- Flowshop plants, batch processes in, 97–99
- Fluid flows
 - estimating utility costs of heat-transfer fluids, 223
 - performance curves for, 714, 719–720
 - pressure loss due to friction, 693–694
 - rate equations for, 698
- Fluid head, centrifugal pumps, 715
- Fluid model. See Phase equilibrium model
- Fluidized bed, methods for avoiding reactor hot spots, 797
- Fluidized catalytic cracking (FCC), of solids, 429
- FMEA (Failure mode and effects analysis), in Process Hazard Analysis requirement, 901
- Formation stage, in group evolution, 940–941
- FORTTRAN program, creating user-added models, 553
- Fossil fuels, impact on overall utility costs, 209–211
- Fouling
 - considerations relating to when to purify the feed, 60
 - impact on heat-exchanger performance, 714
- FR (Federal Register), 888–889
- Friction
 - factors affecting, 718
 - Moody diagram for, 700
 - pressure loss due to, 693–694
 - system curve for measuring losses, 700–702
- Friction (interpersonal), sources of group friction, 935–938
- FTA (Fault-tree analysis), in Process Hazard Analysis requirement, 901
- Fuel costs
 - impact on overall utility costs, 209–211
 - inflation and, 250
- Fugacity coefficient. See Phase equilibrium model
- Fugitive emissions
 - planned emissions and, 895
 - reducing in green engineering, 922
- Function Block Diagram (FBD), types logic controls, 667
- Fundamentals of Engineering (FE) exam, 875–878
- Furnaces
 - bare module factors in costs, 1028, 1032
 - cost curves for purchased equipment, 1012
 - cost equation for purchased equipment costs, 1006
 - pressure factors in costs of, 1022
 - selecting equipment parameters in PFD synthesis, 395
- Future value, investments and, 235
- G**
- Gantt charts
 - group scheduling and, 942–943
 - multiproduct sequence, 99, 105
 - nonoverlapping operations, overlapping operations, and cycle times, 94–97
 - parallel process units, 106
 - scheduling batch processes, 93–94
 - single and multiproduct campaigns, 101
- Gas law, 695–696

- Gas phase
 reactor design and, 361
 reasons for operating at conditions of special concern, 143
- Gas-phase reaction, effect of temperature and pressure on reaction rate, 792
- Gas-treatment processes, electrolyte applications, 416
- Gasifier, steady-state simulation of, 559–562
- Gauss-Legendre method, as multistep integrator, 621
- Gear's method, as multistep integrator, 621
- General duty clause, of OSHA Act, 889
- General expenses
 calculating, 207
 overview of, 205–206
- General process hazards factor, in Dow Fire & Explosion Index, 906
- Generic block flow diagrams (GBFDs)
 as intermediate step between process concept and PFD, 57–60
 synthesizing PFD from. See Synthesis of PFD, from BFD
- GENI (goal, equation, need, and information) method, for solving quantitative problems, 695
- Gibbs free energy
 calculating energy excess, 434–437
 electrolyte systems and, 418–419
 solids modeling and, 430
- Global optimum
 defined, 452
 finding, 455
- Globalization
 of chemical industry, 115–116
 steady-state simulation for competitive advantage in global economy, 552
- Goal, equation, need, and information (GENI) method, for solving quantitative problems, 695
- Grade-level horizontal, in-line arrangement, plant layout, 28, 30
- Graphical representations
 for friction factors, 700–702
 for heat exchangers, 702–704
 overview of, 700
- Grassroots (green field) costs, estimating cost of new facility, 193–195
- Green engineering, 919–920
- Green engineering
 analyzing PFD in terms of pollution and environmental performance, 922–923
 economics of pollution prevention, 923–924
 environmental laws and, 917
 environmental regulations and, 915–916
 fate of chemicals in environment, 916–919
 green engineering, 919–920
 life-cycle analysis and, 924–925
 overview of, 915
 pollution prevention during process design, 920–922
 review questions and problems, 927
 summary and references, 926–927
- Green field (grassroots) costs, estimating cost of new facility, 193–195
- Green solvents, 919
- Gross profit margin, 459
- Groups. See also Teams
 assessing and improving effectiveness of, 935
 characteristics of effective, 932
 choosing members, 938–939
 coordination of effort in, 934
 effectiveness and, 931–932
 evolutionary stages of, 940
 group formation stage, 940–941
 leadership of, 938
 mobile truth issues, 940
 norming stage of, 941–943
 organization of, 938
 organizational behaviors and strategies, 935
 overview of, 931
 performing stage of, 941–943
 resource materials for, 947–948
 review questions and problems, 949–950
 roles and responsibilities in, 940
 sources of friction in, 935–938
 storming stage of, 941
 summary and references, 948–949
 task differentiation in, 932–933
 when groups become teams, 943–944
 work environment and, 933–934
- Groupthink, 940
- Guide words, HAZOP, 902
- Guidelines for Technical Management of Chemical Process Safety* (AIChE), 893
- H**
- Hazard Communication Standard (HazCom), 890–891
- Hazardous air pollutants (HAP), 895
- Hazardous Data Bank (HSDB), 889
- Hazards
 considerations relating to when to purify the feed, 60–61
 eliminating unwanted by-products, 462–463
 publications regarding chemical hazards, 889
 separator design and, 364
 worst-case scenario required in hazard assessment, 897
- Hazards and operability study (HAZOP)
 applying to feed heater in HDA process, 903–905
 identifying potential hazards, 887
 process hazards analysis, 901–902
- HazCom (Hazard Communication Standard), 890–891
- HAZWOPER (OSHA Hazardous Waste and Emergency Operations) rule, 897
- Headers, utility streams supplied via, 641–642
- Health, safety, and environment (HSE)
 accident statistics, 886–887
 air contaminants standards (OSHA and NIOSH), 890
 chemical engineer's role in, 888
- Chemical Safety and Hazard Investigation Board, 909
- Dow Chemical Hazards Index, 909
- Dow Fire & Explosion Index, 906–909
- emergency release of emissions, 895–896
- Environmental Protection Agency (EPA), 894
 fires and explosions, 898–900
- Hazard Communication Standard (HazCom), 890–891
- HAZOP technique for process hazards analysis, 901–905
 inherently safe design strategy for, 909–910
 minimum MSDS requirements, 891–892
 nongovernmental organizations (NGOs), 897–898
- OSHA and NIOSH, 889
 overview of, 885
 planned emissions, 894–895
 pressure-relief systems, 900
- Process Hazard Analysis requirement, 900–901
- Process Safety Management of Highly Hazardous Chemicals, 892–893
- Process Safety Management (PSM), 893–894
- Registration, Evaluation, Authorization and Restriction of Chemicals (REACH), 891
 regulations and agencies, 888–889
 review questions and problems, 913–914
 risk assessment, 886
 Risk Management Plan (RMP), 896–897
 summary and references, 910–913
 worst-case scenarios, 887–888
- Heat
 exchanging between process streams and utilities, 662–665
 reactor performance related to ability to add/remove, 796
 utility streams and, 687
- Heat capacity
 building model of distillation column for electrolyte system, 438
 gathering physical property data for PFD design, 359
 physical properties related to thermodynamics, 404
 simulation of, 390
 standard-state, 419–420
- Heat-exchanger network synthesis analysis and design (HENSAD), 532
- Heat-exchanger networks (HENs)
 algorithm for solving minimum utility problem, 502
 comparing with mass exchange networks, 533–534
 designing based on pinch, 508–513
 effectiveness factor (F) applied to shell-and-tube exchangers, 520–526
 example solving minimum utility (MUMNE) problem, 503–508
 impact of changing temperature on overall costs, 514

- impact of materials of construction and operating pressures on heat exchangers, 528–530
 - pinch technology and, 500
 - Heat exchangers
 - adjusting overall heat transfer coefficient for, 666
 - avoiding reactor hot spots, 797–799
 - bare module factors in costs, 1028
 - calculating minimum number in MUMNE algorithm, 507
 - composite enthalpy curves for estimating surface area of, 517–520
 - cost curves for purchased equipment, 1013
 - cost equation for purchased equipment costs, 1007
 - debottlenecking strategies for, 758
 - distillation column performance and, 754
 - dynamic models for, 609
 - dynamic simulation of, 613–614
 - effectiveness factor (F) applied to, 520–526
 - equipment-dependent and equipment-independent relationships, 689–690
 - evaluating profitability of equipment with different operating lives, 283–284
 - evaluation of, 156–157
 - evaluation of large temperature driving force in, 156
 - example of DME reactor feed and effluent heat-exchange system, 501–502
 - Exchanger Design and Rating (EDR), 613–614
 - for exchanging heat between process streams and utilities, 662–665
 - factors in design of, 359
 - fouling impacting performance of, 714
 - heuristics for, 348
 - input/output model for, 687–688
 - material factors in costs of, 1026
 - performance curves, 710
 - performance equation for, 763
 - pressure factors in costs of, 184–185, 1022
 - reactor design and, 361
 - reasons for operating at conditions of special concern, 147
 - reducing heat generated by exothermic reactions, 750
 - selecting equipment parameters in PFD synthesis, 395
 - simple and rigorous options in dynamic simulation, 612–613
 - T - Q diagrams for, 702–704
 - temperature increase impacting reaction rate, 753
 - Heat integration
 - example of DME reactor feed and effluent heat-exchange system, 501–502
 - in green engineering, 921
 - network design and, 500
 - Heat transfer
 - adjusting overall heat transfer coefficient for heat exchanger, 666
 - avoiding reactor hot spots, 797–799
 - in chemical reactors, 796–799
 - estimating utility costs of heat-transfer fluids, 223
 - factors in reactor performance, 786
 - film heat transfer coefficients, 512
 - key performance relationships, 694
 - performance curves for, 709
 - performance of reactor/heat transfer combination, 749–752
 - pinch technology and, 500
 - rate equations for, 698–700
 - T - Q diagrams for, 703
 - temperature increase impacting reaction rate, 752–753
 - Heaters
 - cost curves for purchased equipment, 1012
 - cost equation for purchased equipment costs, 1007
 - dynamic simulation and, 609–612
 - fluid system components, 720
 - pressure factors in costs of, 1023
 - reasons for operating at conditions of special concern, 147
 - Heating loops
 - determining maximum flow rate for Dowtherm A, 761–765
 - performance of multiple unit operations, 759–761
 - Henry's Law
 - applying to model for sour-water stripper (SWS), 426
 - applying to model of distillation column for electrolyte system, 438
 - electrolyte models and, 418
 - properties impacting environment fate of chemicals, 918
 - Heuristics
 - characteristics of, 855
 - exercises applying, 335–338
 - experience-based principles in process design, 332–333
 - physical property-related, 340
 - Heuristics, equipment-related
 - for compressors, fans, blowers, and vacuum pumps, 347
 - for drivers and power recovery equipment, 343
 - for drums (process vessels), 344
 - for heat exchangers, 348
 - for liquid-liquid extraction, 353
 - for packed towers (distillation and gas absorption), 352
 - for piping, 346
 - for pressure and storage vessels, 345
 - for pumps, 346
 - for reactors, 354
 - for refrigeration and utility specifications, 355
 - for thermal insulation, 349
 - for towers (distillation and gas absorption), 350
 - Heuristics, ethics-related
 - codes of ethics, 862–863
 - overview of, 870–871
 - reasons for ethical behavior, 855–856
 - right (moral) decisions, 857
 - Heuristics, group-related
 - for coordination, 934
 - for improving work environment, 933
 - for task differentiation, 932–933
 - High-pressure phase separator, 156
 - High-pressure steam (41.0 barg), estimating utility costs, 220–221
 - Highest expected cost range example, in capital cost estimation, 166
 - HIMI (Human machine interface), OTS system and, 38, 676
 - Holding-in-place, intermediate storage and, 104
 - Homogeneous reactions, reactor design and, 361
 - Hot spots, in exothermic reactions, 796–797
 - HSDB (Hazardous Data Bank), 889
 - HSE. See Health, safety, and environment (HSE)
 - Human machine interface (HIMI), OTS system and, 38, 676
 - Humidity, effect of ambient conditions on dynamic models, 608–609
 - Hurdle rates
 - for acceptable rate of return, 282
 - impact on Monte-Carlo simulations, 309
 - Hydrodeallylation of toluene. See Toluene HDA process
- ## I
- Ideas
 - brainstorming in product design, 116, 119–120
 - comparing product design strategies, 117
 - IDLH (Immediately dangerous to life and health), standards for exposure limits, 890
 - Ignition energy, 898
 - Ignition, in reactor, 378
 - IL (Instruction Lists), types logic controls, 667
 - Immediately dangerous to life and health (IDLH), standards for exposure limits, 890
 - Immersive training simulators (ITS)
 - linking with OTS systems, 40–43
 - overview of, 38–40
 - Implement phase, in troubleshooting strategy, 824
 - Implicit Euler method, 620
 - Implicit methods, 620
 - Impurities
 - considerations relating to when to purify the feed, 60–61
 - example of controlling product purity in distillation column, 654–655
 - Incidence rate (OSHA), for illness and injury, 886–887
 - Incremental analysis, in optimization, 458
 - Incremental economic analysis
 - comparing large projects, 279–282
 - discounted method, 291–292
 - nondiscounted method, 289–291
 - retrofitting facilities, 289–293

- Incremental net present value (INPV)
 evaluating pollution prevention, 923–924
 evaluating retrofitting, 292–293
- Incremental payback period (IPBP), nondiscounted method for incremental analysis, 289–290
- Inequality constraints, 452
- Inert materials
 added to feed to control equilibrium reactions, 62
 added to feed to control exothermic reactions, 61–62
 impact on equilibrium or reactor operation, 72
 methods for avoiding reactor hot spots, 797
 reasons for non-stoichiometric feed composition of special concern, 145
 tracing chemical components in PFD, 135
 when to recycle, 71
- Inflation
 consequences of, 252
 distinguishing between cash and purchasing power of cash, 251–252
 formula for rate of, 251
 overview of, 250
 trends in capital costs over time, 171–172
- Information
 collection and synthesis stage of process flow diagram, 78
 needed in synthesis of PFD from BFD, 358–360
- Information flags, adding stream information to diagram via, 18–21
- Information (input data), for simulators
 chemical component selection, 389–390
 convergence criteria for simulation, 400–401
 equipment parameters, 393–400
 feed stream properties, 393
 flowsheet topology, 392–393
 output display options, 400
 overview of, 389
 physical property models, 390–392
- Inherently safe design strategy, for plant safety, 909–910
- Initialization step, in dynamic simulation, 618–619
- Input/output models
 analyzing effect of inputs on outputs, 689–690
 classification of process analysis, 688
 for individual pieces of equipment, 687–688
 overview of, 685–686
 for production of benzene by HDA of toluene, 690–691
 for pump, heater exchanger, and distillation column, 687–688
 representing inputs and outputs, 686–687
 review questions and problems, 692
 summary, 691
- Input/output structure, in process flow considerations regarding and alternatives, 60–62
- example illustrating, 73–78
 generic block flow diagram as intermediate step between process concept and PFD, 57–60
 information obtained from, 62–64
 of process concept diagrams, 54–55
 of process flow diagrams, 55–57
- Input streams, types of process flow streams, 687
- Input variables (inputs). See also Input/output models
 analyzing effect of inputs on outputs, 689–690
 defined, 601
 distillation of benzene from toluene, 754
 performance curves representing relationship between input and outputs, 708
 problem types and, 821
 representing, 686–687
- INPV (Incremental net present value)
 evaluating pollution prevention, 923–924
 evaluating retrofitting, 292–293
- Insider information, whistle-blowing and, 869
- Instruction Lists (IL), types logic controls, 667
- Instrument engineers, uses of P&IDs, 25
- Instrumentation, conventions used for identifying on P&IDs, 22, 24
- Integrated Risk Information System (IRIS), 889
- Integrator methods (numerical)
 Euler method, 620
 example of impact of method choice, 622–624
 explicit and implicit methods, 620
 linear/nonlinear equation solvers, 622
 multistep methods, 621
 predictor-corrector methods, 621–622
- Integrity, question of, 862
- Intensification, in inherently safe design, 910
- Intention, HAZOP, 902
- Interest
 compound, 238–239
 simple, 238
 time basis in calculating compound, 240–241
- Interest rates
 changing over time, 239
 discounted cash flow rate of return (DCFRROR), 277–278
 earnings on investment and, 235
 effective rate adjusted for inflation, 251
 rate of return on investment (ROROI), 272
- Intermediate-boiling component, breaking binary azeotrope using, 375
- International chemical safety card, 891
- Interpersonal/communication skills, 924–925
- Investments
 acceptable levels for rate of return, 282–283
 comparing alternatives, 281
- comparing savings with investing, 234–235
 depreciation of capital, 253–254
 overview of, 234
 rate of return on investment (ROROI), 272
 return on incremental, 458
 value of, 235–237
- Investors, 235–236
- Ionic reactions. See also Electrolyte systems modeling
- Ionic reactions, building model of distillation column, 437
- IPBP (Incremental payback period), nondiscounted method for incremental analysis, 289–290
- IRIS (Integrated Risk Information System), 889
- ISA-55-1, conventions for instrumentation on P&IDs, 24
- Iterations, convergence criteria for simulation, 400
- ITS (Immersive training simulators)
 linking with OTS systems, 40–43
 overview of, 38–40
- ## J
- Jacobian matrix
 applying to thermodynamic properties, 554
 Broyden's method and, 571
 comparing methods for tear stream convergence, 574
 direct substitution and, 569
 equation-oriented (EO) approach and, 577
 Newton's method and, 570, 572
 Wegstein's method and, 570
- Jobshop plants, batch processes in, 99–102
- Jones-Dole model, for viscosity, 438–439
- ## K
- K-factor. See Phase equilibrium model
- Kinetic reactors
 designing, 360–361
 evaluation of, 151–153
 selecting equipment parameters in PFD synthesis, 396
- Kinetics
 effects observed in reactions, 787
 evaluation of reactions, 154
 gathering reaction data for PFD design, 358–359
 key performance relationships, 694
 reaction kinetics, 750, 785, 788–790
 reactor design and, 360–361
 resource materials for, 79
- Kremser equation, 729–732, 822
- ## L
- Labor costs
 example of, 205
 inflation and, 250
 in manufacturing cost estimation, 208–209

- Labor needs, considerations in deciding to use continuous or batch processes, 52
- Ladder Diagrams (LD)
 components of, 667–668
 example applying to storage vessel schematic, 668–669
 types logic controls, 667
- LAL (Level alarm low), troubleshooting cumene process feed section, 830
- Lang Factor method, estimating plant cost with, 176–177
- Langmuir-Hinshelwood
 expressions, 558
 kinetics, 789
- Langrangian function, in quadratic programming, 582
- Large temperature driving force, in exchanger, 156
- Lattice search, vs. response surface techniques, 478
- LCA (life-cycle analysis), of environmental consequences, 924–925
- LD. See Ladder Diagrams (LD)
- Leadership, of groups, 938
- Learning, in teams, 946–947
- Least-squares criteria, for determining objective function, 586–587
- Legality
 environmental laws, 917
 ethics cases, 871
 liability and, 879–880
 reasons for ethical behavior, 856
- LEL (lower explosive limit), 898
- Lennard-Jones potential, in thermodynamics, 555
- Level alarm low (LAL), troubleshooting cumene process feed section, 830
- LFL (lower flammability limit), 898
- Life-cycle analysis (LCA), of environmental consequences, 924–925
- Life of equipment, depreciation and, 255
- Linear-in-parallel (LIP) model, estimating physical property parameters, 586
- Linear/nonlinear equation solvers, 622
- Linear programming, 452
- Linear quadratic control (LQC), types of model-based controls, 670
- Linear valves, in flowrate control, 645
- LIP (linear-in-parallel) model, estimating physical property parameters, 586
- Liquid-Liquid equilibrium (LLE), 409
- Liquid-Liquid extractors, selecting equipment parameters in PFD synthesis, 399–400
- Liquid-state activity-coefficient models
 hybrid systems, 411
 LLE, 409
 overview of, 405
 strategy for choosing, 409–410
 types of phase equilibrium models, 407–410
 VLE, 408
- Liquids
 estimating manufacturing costs of liquid waste, 228
- flowrate feedback controls for pumping, 660–662
- heuristics for liquid-liquid extraction, 353
- liquid-phase reaction, 792
- measurement of liquid level, 649
- Loans, banks and, 236
- LOCA (loss of coolant accidents), exothermic reactions, 900
- Local optimum, 452
- Local truncation error (LTE), predictor-corrector methods and, 622
- Logic control system, 666–669
- Logic ladder diagrams, 27
- Loss control credit factors, American Institute of Chemical Engineers (AIChE), 908–909
- Loss of coolant accidents (LOCA), exothermic reactions, 900
- Low alloy steel, selection of materials of construction, 186
- Low-pressure steam (5.2 barg), estimating utility costs, 222
- Lower flammability (or explosive) limit (LFL or LEL), 898
- Lowest expected cost range, in capital cost estimation, 165–166
- LQC (linear quadratic control), types of model-based controls, 670
- LSSQP, comparing approaches to tear convergence, 579–580
- LTE (local truncation error), predictor-corrector methods and, 622
- Lumped-parameter models
 dynamic models for heat exchangers, 609
 dynamic models for utility heaters/coolers, 609–610
- M**
- M-C. See Monte-Carlo (M-C) method
- MAC (model algorithmic control), types of model-based controls, 670
- MACRS (modified accelerated cost recovery system), 258–259
- Maintenance, simulation in training for, 41–43
- Manipulated variables (MVs)
 challenges of dynamic simulation, 603
 defined, 601
 process control in dynamic simulation, 625
 split-range control system and, 657
- Manufacturing cost estimation
 categories of cost information, 203
 cooling tower water, 211–215
 cost determination example, 207–208
 equations for determination of, 206–207
 evaluating production of benzene via toluene HDA process, 228–229
 factors affecting, 204–205
 heating heat-transfer fluids, 223
 high-pressure steam, 220–221
 liquid and solid wastes, 228
 low-pressure steam, 222
 medium-pressure steam, 221–222
- operating labor costs, 208–209
 overview of, 161, 203
 raw materials, 223–224
 refrigeration, 215–218
 review questions and problems, 230–232
 steam production, 218–220
 summary and references, 229–230
 utility cost background, 209–211
 utility cost calculation, 211
 utility cost estimation from PFD, 225–228
 waste heat boilers, 223
 yearly costs and stream factors (SF), 225
- Manufacturing, product design and, 117, 122
- Margins
 analyzing base costs in optimization process, 459
 evaluating, 310–311
- Margules equation, solids modeling and, 431
- Marshall and Swift Equipment Cost Index
 inflationary trends in capital costs over time, 171–172
 values 1996 to 2011, 173
- Mass-exchange networks (MENs)
 comparing heat-exchange networks with, 533–534
 examples, 535–541
 mass integration and, 923
 overview of, 532–533
 pinch technology and, 500
- Mass separating agents, 728–733
- Mass transfer
 catalytic reactions and, 808
 pinch technology and, 500
 rate equations for, 698
 reactor performance controlled by resistances to, 789
- Material balance
 controlling, 642–643
 feedback control system for, 672–675
- Material balance, energy balance, rate equations, hydraulic equations, and equilibrium equations (MERSHQ), 424
- Material balance, phase equilibrium, summation equations, and enthalpy balance (MESH), 423–424
- Material factors, in equipment costs, 1025–1027
- Material safety data sheets (MSDS)
 Hazard Communication Standard (HazCom) and, 890
 minimum requirements for, 891–892
 typical sections of, 891
- Materials of construction (MOCs)
 advantages/disadvantages of, 342
 combining pressure and MOC information to get bare module cost, 191
 corrosion characteristics of, 187–188
 costs of, 189–191
 pinch technology and, 528–530
 types of, 186, 189
- Maximum likelihood criteria, for determining objective function, 587

- MBTI (Myers-Briggs Type Indicator), in evaluation of engineering students, 938
- McCabe-Thiele
binary azeotropic distillation and, 369–370
for evaluating theoretical stages, 734–736
- Measurement, of process variables, 649
- Mechanical engineers, uses of P&IDs, 25
- Mechanical flow diagram (MFD). See Piping and instrumentation diagrams (P&ID)
- Medium-pressure steam (10.0 barg), estimating utility costs, 221–222
- Melting point, properties impacting environment fate of chemicals, 918
- Membrane separation
approaches to recycling unreacted raw materials, 67
economics of, 370
- MENs. See Mass-exchange networks (MENs)
- MERSHQ (material balance, energy balance, rate equations, hydraulic equations, and equilibrium equations), 424
- MESH (material balance, phase equilibrium, summation equations, and enthalpy balance), 423–424
- Metal mass
heater exchangers and heaters/coolers and, 612
temperature transient and, 608–609
- Metallurgy, solid-liquid equilibrium and, 429
- Method of lines, approaches to dynamic simulation, 617
- Metric units, diagram options for engineering units, 27
- MFD (mechanical flow diagram). See Piping and instrumentation diagrams (P&ID)
- Microeconomic theory, 295–298
- Mine Safety and Health Administration (MSHA), 889
- Minimum Gibbs Free Energy reactors, 396
- Minimum number of exchangers (MUMNE)
algorithm for solving minimum utility problem, 502
design combining with minimum amount of utilities, 500
example, 503–508
examples, 535–541
HENSA program addressing, 532
- MINLP (Mixed-integer nonlinear programming), 452
- Mission, group formation and, 941
- Mixed-integer, 452
- Mixed-integer nonlinear programming (MINLP), 452
- Mixers
bare module factors in costs, 1033
cost curves for purchased equipment, 1019
cost equation for purchased equipment costs, 1007
operations in tracing chemical pathways, 125–126
reasons for operating at conditions of special concern, 147
selecting equipment parameters in PFD synthesis, 395–396
tracing chemical pathways, 125–126
- Mob effect, 940
- Mobile truth, group-related issue, 859–861, 940
- MOCs. See Materials of construction (MOCs)
- Model algorithmic control (MAC), types of model-based controls, 670
- Model-based controls, 670
- Model Predictive Control (MPC), types of model-based controls, 670
- Modified accelerated cost recovery system (MACRS), 258–259
- Modular method, solutions to DAE systems, 619
- Module costing technique
algorithm for calculating bare module costs, 191–193
bare module equipment costs at base conditions, 177–181
bare module equipment costs at non-base conditions, 181–185
grassroots vs. total module costs, 193–195
materials of construction (MOCs) and, 186–191
overview of, 177
- Molar volume
building model of distillation column for electrolyte system, 438
estimating for electrolyte system, 420
- Monte-Carlo (M-C) method
CAPCOST program applying, 310
evaluating risks associated with new technology, 308–310
quantifying risk, 302
simulation using, 405
steps in, 305–308
- Moody diagram, for friction factors, 700–701
- Morality
exemplars of, 871
moral autonomy of engineers, 857
reasons for ethical behavior, 856
- MPC (Model Predictive Control), types of model-based controls, 670
- MSDS. See Material safety data sheets (MSDS)
- MSHA (Mine Safety and Health Administration), 889
- Multistage extraction, 689–690
- Multistep methods, numerical integrator methods, 621
- MUMNE. See Minimum number of exchangers (MUMNE)
- Myers-Briggs Type Indicator (MBTI), in evaluation of engineering students, 938
- N**
- NAFTA (North American Free Trade Agreement), 872
- National Ambient Air Quality Standards (NAAQS), 895
- National Council of Examiners for Engineering and Surveying (NCEES)
FE exam, 875, 877–878
PE exam, 858–879
- National Emissions Standards for Hazardous Air Pollutants (NESHAP), 895
- National Institute for Engineering Ethics (NIEE), 871
- National Institute for Occupational Safety and Health (NIOSH)
air contaminants standards, 890
overview of, 889
- National Response Center, Coast Guard
regulation of pollution in coastal waters, 896
- National Society of Professional Engineers (NSPE)
codes of ethics, 866–867
engineering ethics, 873–874
- Nationally Recognized Testing Laboratory (NRTL)
calculating Gibbs free energy for electrolyte systems, 418–419
liquid-state activity-coefficient models, 409–410
- Needs analysis, in chemical product design, 116–119
- Net Positive Suction Head (NPSH)
pump performance and, 723–727
troubleshooting cumene process feed section, 829–830
- Net present value (NPV)
in CAPCOST program, 310
cash-related criteria in project evaluation, 275–278
comparing investment alternatives and, 281
computing, 280–281
evaluating profitability of equipment with same operating lives, 283–284
in profitability analysis, 162
scenario analysis for quantifying risk, 299
sensitivity analysis for quantifying risk, 300–302
- Net present worth (NPW), in project evaluation, 275–277
- New Source Performance Standards (NSPS), of EPA, 895
- Newton's method
applied to tear stream convergence, 571, 574
equation-oriented (EO) approach and, 577
steady-state simulation algorithms, 570–571
- Nickel (and its alloys), selection of materials of construction, 186, 189
- NIOSH *Pocket Guide to Chemical Hazards*, 890

- NLP. See Nonlinear programming (NLP)
- Nominal annual interest rate, 240
- Non-stoichiometric feed
 evaluation of process conditions for reactors, 154–155
 reasons for operating at conditions of special concern, 145
- Nondiscounted criteria, in evaluation of profitability, 271–275
- Nonferrous alloys, selection of materials of construction, 186
- Nongovernmental organizations (NGOs)
 American Conference of Governmental and Industrial Hygienists (ACGIH), 890
 list of organizations and standards, 897–898
 rules for health, safety, and environment, 889
- Nonlinear programming (NLP)
 applied to optimization studies, 581–582
 defined, 452
 solving nonlinear MPC problems, 670
- Nonoverlapping operations, in batch process sequence, 94–95
- Nonprofessional responsibilities, in ethical problem solving, 862
- Nonreacting chemicals. See also Inert materials, 135
- Norming stage, in group evolution, 941–943
- North American Free Trade Agreement (NAFTA), 872
- NPSH (Net Positive Suction Head)
 pump performance and, 723–727
 troubleshooting cumene process feed section, 829–830
- NPW (Net present worth), in project evaluation, 275–277
- NRTL (Nationally Recognized Testing Laboratory)
 calculating Gibbs free energy for electrolyte systems, 418–419
 liquid-state activity-coefficient models, 409–410
- NSPS (New Source Performance Standards), of EPA, 895
- O**
- Objective function
 defined, 452
 estimating physical property parameters, 586–587
 identifying and prioritizing decision variables, 460
 modeling in terms of decision variables, 476–477
 parametric optimization and, 478
 selecting in optimization, 458–459
 sensitivity to changes in decision variables, 476
 single-variable optimization example, 468–469
- Obligations, ethics/professionalism, 862
- Occupational Safety and Health Administration (OSHA)
 environmental laws, 917
 HAZWOPER rule, 897
 Octanol-water partition coefficient, 918
 ODEs. See Ordinary differential equations (ODEs)
- Open-cup method, for measuring flash point, 899
- Open-loop response, dynamic simulation and, 624
- Operating cost methods, evaluating retrofitting with, 292–293
- Operating labor costs
 in formula for COM, 205
 in manufacturing cost estimation, 208–209
- Operation blocks, process simulators and, 562
- Operator training simulators (OTS)
 building, 37–38
 linking immersive training simulator with, 40–43
 training control room operators, 676–677
- Operators
 linking immersive training simulator with OTS, 40–43
 operator training simulators (OTS), 37–38
 training control room operators, 676–677
 using P&IDs in operator trainings, 25–26
- Optimization
 base case approach to, 457–458
 base cost analysis, 459–460
 batch systems and, 479
 communicating results of, 456–457
 early identification of alternatives as aid in, 360
 eliminating equipment in, 463–464
 eliminating unwanted hazardous by-products, 462–463
 estimating difficulty of, 455
 flexibility of process and sensitivity of the optimum, 479
 flowsheet optimization using decision variables, 473–477
 identifying and prioritizing decision variables, 460–461
 lattice search vs. response surface techniques, 478
 misconceptions in, 453–454
 optimum cycle time for batch processes and, 484–487
 overview of, 327, 451
 parametric optimization, 467–468
 rearranging equipment, 464–466
 reasons for multiple reactors, 71
 review questions and problems, 488–497
 scheduling equipment for batch processes, 479–484
 selecting the objective function for, 458–459
 separation and reactor configuration alternatives, 466–467
 single-variable example, 468–470
 steady-state simulators used in optimization studies, 581–583
 strategies for, 457
 summary and references, 487–488
 terminology-related to optimization, 452
 top-down and bottom-up strategies, 455–456
 topological optimization, 460–461
 two-variable example, 470–473
- Optimum cycle time, for batch processes, 484–487
- OR gate, in FTA and FMEA analyses, 901
- Order-of-Magnitude (ratio or feasibility), cost estimation, 164–165
- Ordinary differential equations (ODEs)
 converting DAEs to, 619
 explicit and implicit methods, 620
 linear/nonlinear equation solvers and, 622
 process simulators solving, 618
 steady-state simulation and, 617
- Organization, of groups, 938
- Organizational behaviors, 935
- OSHA Hazardous Waste and Emergency Operations (HAZWOPER) rule, 897
- OSHA (Occupational Safety and Health Administration), 917
- Output display options, selecting for simulation presentation, 400
- Output streams, types of process flow streams, 687
- Output variables (outputs). See also Input/output models
 analyzing effect of inputs on, 689–690
 defined, 601
 distillation of benzene from toluene, 754
 performance curves representing relationship between input and outputs, 708
 problem types and, 821
 representing, 686–687
- Overall conversion
 of reactant, 787
 vs. single pass conversion impacting efficiency of use of raw materials, 65–66
- Overlapping operations, in batch process sequence, 96
- P**
- Packed-bed absorber, troubleshooting case study, 825–829
- Packed towers (distillation and gas absorption), 352
- Packing
 cost curves for purchased equipment, 1014
 cost equation for purchased equipment costs, 1007
 pressure factors in costs of, 1023
- Paper-and-pencil studies, in capital cost estimation, 166
- Parallel process units, increasing production using, 106–107
- Parallel reactions, reaction kinetics and, 787
- Parameters, for solids model, 431–434

- Parametric optimization
 flowsheet optimization using decision variables, 473–477
 overview of, 467–468
 single-variable optimization example, 468–470
 two-variable optimization example, 470–473
- Partial differential equations (PDEs), 617
- Partitioning, in sequential modular approach, 562–565
- Path properties, centrifugal pumps, 714–717
- Pattern search, parametric optimization and, 478
- Payback period (PBP)
 in profitability analysis, 162
 time-related criteria in project evaluation, 271
- PBP (payback period)
 in profitability analysis, 162
 time-related criteria in project evaluation, 271
- PDEs (partial differential equations), 617
- PDEs (professional development hours), in professional registration, 879
- PDMS software, from Cadcentre, 35
- PE (Principles and Practice) exam, 878–879
- PELs (permissible exposure limits), air contaminants standards, 890
- Peng-Robinson (PR) fugacity model, 404–406
- Performance
 analysis, 683–684
 process performance analysis, 688
 of reactors. See Reactor performance
 types of problems, 684, 821
- Performance curves, by unit operations
 compressors, 727–728
 coolant systems, 721
 defined, 708
 distillation and, 733–740
 flowrate regulation and, 720–723
 fluid flow rate example, 719–720
 fluid flows, 714
 heat-exchange system, 710
 heat transfer, 709
 Net Positive Suction Head (NPSH) and, 723–727
 overview of, 707–708
 positive displacement pumps, 723
 predicting effects of changes to operating conditions, 712–713
 pumps and system curves, 714–717
 reading pump curve, 717
 review questions and problems, 741–748
 separation using mass separating agents, 728–733
 shell-and-tube heat exchanger, 711
 steam generator example, 714
 summary and references, 740–741
 understanding system performance before making predictions, 718–719
- Performance evaluation tools
 base-case ratios, 696–698
 controlling resistances in system analysis, 698–700
- equations for use in trend analysis, 694
 for friction factors, 700–702
 GENI method, 695
 graphical representations, 700
 key relationships and, 693–694
 overview of, 693
 predicting trends, 695–696
 review questions and problems, 705–706
 summary and references, 704–705
 T-Q diagram for heat exchangers, 702–704
- Performance, of multiple unit operations
 bottlenecks and debottlenecking strategies, 758–759
 condenser performance impacting distillation column performance, 757–758
 determining maximum flow rate for Dowtherm A, 761–765
 distillation columns, 754–755
 feed system, 765–767
 heating loops, 759–761
 impact of reducing feed rate, 767–768
 increasing conversion in reactor, 753
 increasing temperature to increase reaction rate, 752–753
 overview of, 749
 reactor combined with heat transfer, 749–752
 reboiler performance impacting distillation column performance, 756–757
 review questions and problems, 769–783
 scaling down flows in distillation column, 755
 summary and references, 768–769
- Performing stage, in group evolution, 941–943
- Permissible exposure limits (PELs), air contaminants standards, 890
- PERT (program evaluation and review technique), for group scheduling, 942
- Pervaporation, for purification of ethanol, 369–370
- PFDs. See Process flow diagrams (PFDs)
- PFR reactors. See Plug flow (PFR) reactors
- PHA. See Process hazard analysis (PHA)
- Phase equilibrium model
 equations of state in, 405–406
 selecting for PFD synthesis, 405
 solids modeling and, 431
 VLE constraints and, 587–589
- Phase equilibrium
 binary interaction parameters (BIPs), 405–406
 gathering physical property data for PFD design, 359–360
 MESH (material balance, phase equilibrium, summation equations, and enthalpy balance) in, 423–424
- Phase (state)
 considerations regarding phase of recycle stream, 72–73
 gas phase as reason for operating at conditions of special concern, 143
 reactor design and, 360
- streams with phase changes and pinch technology, 530–532
 vapor phase as reason for operating at conditions of special concern, 146
- Physical properties
 base-case ratios applied to, 697
 gathering data for reactor design, 359
 heuristics for, 340
 impacting fate of chemicals in environment, 918
 measurement of process variables, 649
 related to solids modeling, 429–431
 related to thermodynamics, 404
 steady-state simulators estimating parameters of, 586–589
- Physical property model
 comparing impact of two models, 392
 selecting for PFD synthesis, 390–392
- Physical strength, impact of temperature on strength of materials, 141
- PI (Proportional-integral), 625
- PID (Proportional-integral-derivative), 625–626
- Pilot plants, in development of processes, 54
- Pinch technology
 cascade diagram in determination of pinch temperature, 504
 comparing HENs with MENs, 533–534
 composite enthalpy curves for systems without a pinch, 516
 composite temperature-enthalpy diagram, 514–516
 design above the pinch, 507–508
 design at the pinch, 508–510
 design away from the pinch, 509–512
 design below the pinch, 508, 510
 determining EAOC of exchanger network, 526–527
 effectiveness factor (F) applied to heat exchangers, 520–526
 estimating surface area of heat exchangers, 517–520
 examples of application of, 512–514
 heat-exchanger network synthesis analysis and design (HENSAD), 532
 heat integration and network design, 500
 materials of construction and operating pressure issues, 528–530
 MENs, 532–533, 535–541
 multiple utilities and, 530
 overview of, 499–500
 review questions and problems, 542–550
 solving minimum utility (MUMNE) problem, 502–508
 streams with phase changes and, 530–532
 summary and references, 541–542
- Pinch zone, 504
- Piping
 conventions used in drawing P&IDs, 22
 diameter in relationship to friction losses, 693–694
 fluid system components, 720
 headers, 641–642
 heuristics for, 346
 isometrics, 27

- Piping and instrumentation diagrams (P&ID)
 - benzene distillation stages, 26
 - conventions used for identifying instrumentation, 24
 - conventions used in drawing, 22
 - Kauffman on, 4
 - overview of, 21–26
 - plant layout based on information in, 28–35
- Piping engineers, uses of P&IDs, 25
- Pitzer models, calculating Gibbs free energy for electrolyte systems, 418–419
- Planned emissions, 894–895
- Plant costs
 - bare module equipment costs at base conditions, 177–181
 - bare module equipment costs at non-base conditions, 181–185
 - calculating bare module costs, 191–193
 - CAPCOST for calculating bare module costs, 196–198
 - CEPCI and Marshall and Swift indices, 173
 - CEPCI applied to account for inflation, 175–176
 - factors affecting, 174–175
 - grassroots vs. total module costs, 193–195
 - Lang Factor method, 176–177
 - materials of construction (MOCs) and, 186–191
 - module costing technique, 177
 - overview of, 172–173
- Plant layout
 - 3-D view of, 35–37
 - equipment elevation, 33, 35
 - equipment placement, 32–34
 - space between equipment, 31
 - subsystems in, 29
 - types of, 28, 30
 - utility piping added to plan for, 35
- Plants
 - block flow diagrams (BFDs), 6–8
 - dynamic simulation used for modeling start-up or shut-down, 603
 - P&ID in planning construction, 21
 - strategy for troubleshooting existing, 823
- PLC (programmable logic controller), 667
- Plot plans
 - for equipment placement, 32–33
 - for PFD subsystems, 28
 - types of auxiliary diagrams used, 27
- Plug flow (PFR) reactors
 - case study replacing catalytic reactor in benzene process, 800–804
 - compared with CSTR reactors, 791–796
 - concentration profiles for series reaction, 796
 - dynamic models for, 616–617
 - as hypothetical system, 792
 - methods for avoiding reactor hot spots, 797
 - performance equation for, 791
 - reactor models and, 793–794
 - selecting equipment parameters in PFD synthesis, 396
- Poisons, considerations relating to when to purify the feed, 60–61
- Pollution
 - analyzing PFD in terms of pollution performance, 922–923
 - economics of prevention, 923–924
 - green engineering and, 378–379
 - prevention during process design, 920–922
- Pollution Prevention Act (PPA), 915, 917
- Polymers
 - selection of materials of construction, 186
 - specialty chemical becoming a commodity chemical, 115
- Pop valves, in pressure-relief systems, 900
- Positive displacement compressors, 728
- Positive displacement pumps, 723
- Postrationalization, in justification behavior, 860
- Power-law-expressions, 558
- Power recovery equipment
 - bare module factors in costs, 1028, 1032
 - cost curves for purchased equipment, 1011
 - heuristics for, 343
 - selecting equipment parameters in PFD synthesis, 395
- PPA (Pollution Prevention Act), 915, 917
- PR (Peng-Robinson) fugacity model, 404–406
- Pre-exponential factor, in Arrhenius equation, 790
- Precedence ordering, in sequential modular approach, 562–565
- Predictive problems, types of performance problems, 684
- Predictor-Corrector methods, numerical integrator methods, 621–622
- Preliminary Design (Scope), in cost estimation, 164–165
- Present value ratio (PVR), in project evaluation, 275–277
- Pressure
 - adjusting vs. changing composition of, 140
 - azeotropic distillation and, 370
 - drop due to friction, 693–694
 - effect on dynamic models, 608–609
 - equipment tolerances (1 to 10 bar rule), 140
 - evaluation of pressure control valves, 157
 - evaluation of process conditions for reactors, 154–156
 - flowrate and, 644, 646–648
 - impact on bare module equipment costs, 181–185
 - increasing pressure of process stream, 660–662
 - information needed to get bare module cost, 191
 - measurement of process variables, 649
 - operating pressure and pinch technology, 528–530
 - optimization example, 470–473
 - reaction rate relationship to, 695–696, 792
 - reactor design and, 360
 - reactor feed design and, 378
 - reasons for operating at conditions of special concern, 144–145
 - regulation of, 646–648
 - system pressure drop, 722
 - thermodynamic limitations on conversion, 790–791
 - troubleshooting cumene reactor, 839
 - troubleshooting packed-bed absorber, 827
 - validity of pressure-flow networks in dynamic simulation, 603–606
- Pressure factors, in costs
 - for other process equipment, 1021
 - for process vessels, 1021
- Pressure-relief systems, 900
- Pressure-relief valves, 900
- Pressure-swing
 - approaches to recycling unreacted raw materials, 67
 - azeotropic distillation and, 370
- Pressure vessels, heuristics for, 345
- Primary flow paths
 - for hydrogen and methane in HDA process, 130–132
 - tactics for tracing chemical species, 126–127
 - for toluene and benzene in HDA process, 127–129
 - tracing reactants and products, 126
- Principal (present value), investments and, 235
- Principles and Practice (PE) exam, 878–879
- Probability
 - applying Monte Carlo analysis to evaluating new technology risks, 308–310
 - applying Monte Carlo analysis using CAPCOST program, 310
 - concepts, 303–305
 - overview of Monte Carlo method, 305–308
 - quantifying risk and, 302
- Probability distribution
 - overview of, 303
 - random numbers and, 306
 - use in Monte-Carlo method, 305
- Problem-solving. See also Troubleshooting
 - estimating problem difficulty, 455–456
 - strategies, 822–823
- Process concept diagrams
 - block flow diagram as intermediate step between process concept and PFD, 57–60
 - for evaluating process route, 54–55
- Process conditions
 - analysis of, 150–151
 - conditions of special concern for operation of equipment, 146–150
 - conditions of special concern for separation and reactor systems and, 140
 - evaluation of exchanger, 156–157

- Process conditions (*continued*)
 evaluation of high-pressure phase separator, 156
 evaluation of large temperature driving force in exchanger, 156
 evaluation of reactors, 151–156
 evaluation of steam control valves, 157
 overview of, 139
 pressure, 140
 reasons for operating at conditions of special concern, 142–146
 review questions and problems, 158–159
 summary and references, 157–158
 temperature, 141–142
- Process design. See also Process flow diagrams (PFDs)
 analysis, 688
 batch vs. continuous processes in, 50–54
 experience-based principles in. See Experience-based principles, in process design
 hierarchy of, 49–50
 input/output models in analysis of, 688
 pollution prevention during, 920–922
- Process flow diagrams (PFDs)
 batch vs. continuous processes, 50–54
 for benzene distillation stages, 26
 collection and synthesis of information related to, 78
 combining recycle of feed and product, 67–70
 combining topology, stream data, and control strategy, 18–21
 considerations regarding input/output structure, 60–62
 equipment information, 16–18
 in estimation of cost of purchased equipment, 167
 generic BFD as intermediate step between process concept and PFD, 57–60
 hierarchy of process design, 49–50
 information obtained from input/output diagrams, 62–64
 input/output structure of, 55–57
 Kauffman on, 4
 methods for recycling unreacted raw materials, 66–67
 overview of, 8–9
 process concept diagrams, 54–55
 process energy recovery system, 78
 process topology, 9–12
 raw material usage, efficiency of, 65–66
 reasons plants do not operate according to expectations, 683
 recycle structure issues, 70–73
 recycle structure of, 64
 review questions and problems, 81–85
 separation system, 78
 starting from BFDs, 5
 stream information, 12–15
 summary and references, 78–81
 synthesizing from BFDs. See Synthesis of PFD, from BFD
 synthesizing using simulators. See Synthesis of PFD, using simulator
- tracing chemical components in. See Chemical components, tracing in PFD
- Process hazard analysis (PHA)
 Dow Chemical Hazards Index, 909
 Dow Fire & Explosion Index, 906–909
 EPA hazard assessment compared with, 897
 HAZOP technique for process hazards analysis, 901–905
- Process Hazard Analysis requirement, 900–901
- Process Safety Management of Highly Hazardous Chemicals
 activities of, 892–893
- Process Hazard Analysis requirement, 900–901
- Process Safety Management (PSM)
 coordination with EPA Risk Management Program, 896
 OSHA standard for chemical hazards, 893–894
- Process Safety Management Regulation of 1992, 893
- Process streams
 identifying stream information in PFDs, 12–13
 information regarding in PFDs, 8
 input/output diagram for, 686
 input/output structure and, 55–56
 types of, 687
- Process topology
 categorization of information in PFDs, 9–12
 combining topology, stream data, and control strategy, 18–21
- Processes
 batch. See Batch processes
 batch vs. continuous in process design, 50–54
 block flow process diagram. See Block flow diagrams (BFDs)
 conceptualization and analysis of, 1–2
 conceptualization and analysis of chemical processes, 1–2
 continuous. See Continuous processes
 control loops. See Control loops
 cooling process streams, 651–653, 654
 descriptions included with PFDs, 137
 energy recovery system, 78
 optimization. See Optimization
 performance analysis using input/output models, 688
 process flow diagrams. See Process flow diagrams (PFDs)
 reasons for operating at conditions of special concern, 147
 regulating. See Controlling/regulating chemical processes
 resource materials for chemical processes, 79
 simulators. See Simulators
 troubleshooting. See Troubleshooting
 types of process flow streams, 687
 unit capacities, 341
 vessels. See Vessels
- Producers, parties in investment, 235–236
- Product chemicals
 cooling and crystallization in batch processes, 92–93
 designing. See Product design
 distillation of reaction products in batch processes, 90–92
 equipment design for multiproduct processes, 107–109
 evaluation of reactors and, 154
 factors in reactor performance, 786
 increasing acetone production, 809–812
 intermediate storage, 104–106
 process concept diagram for identifying, 54–55
 production of desired product in reactor, 786–788
 reactors transforming feed chemicals into, 127
 recycling together with feed, 67–70
 separator design and, 363–364
 storage for single-product campaigns, 102–104
 supply and demand and, 295–298
 tracing, 126
 troubleshooting off-specification product, 831–833
 unwanted products impacting equilibrium or reactor operation, 72
- Product design
 batch processing, 123
 economics of, 123
 equipment design for multiproduct processes, 107–109
 generation of ideas for, 119–120
 manufacturing process and, 122
 overview of, 115–116
 product need and, 117–119
 selection process and, 120–122
 strategies for, 116–117
 summary and references, 123–124
- Professional development hours (PDHs), in professional registration, 879
- Professional registration (certification)
 engineer-in-training certification, 875–878
 overview of, 874–875
- Principles and Practice (PE) exam, 878–879
- Professionalism. See Ethics/professionalism
- Profit, impact of tax rate on, 259–261
- Profit margins
 economics of chemical product design, 123
 evaluating, 310–311
 information obtained from input/output diagrams, 62–64
- Profitability analysis
 applying Monte Carlo analysis using CAPCOST program, 310
 cash flow diagram for new project, 269–271
 criteria in evaluating profitability, 271
 discounted criteria and, 275–279
 evaluating equipment with different operating lives, 284–288

- evaluating equipment with same operating lives, 283–284
- evaluating risks associated with new technology, 308–310
- forecasting uncertainty in chemical processes, 294–298
- incremental analysis for comparing large projects, 279–282
- incremental analysis for retrofitting facilities, 289–293
- Monte Carlo Simulation (M-C) probability method, 305–308
- nondiscounted criteria, 271–275
- overview of, 162, 269
- probabilistic approach to quantifying risk, 302
- probability concepts, 303–305
- profit margins in, 310–311
- quantifying risk, 298
- range of factors in, 294
- rate of return on investment and, 282–283
- review questions and problems, 312–325
- risk and, 293–294
- scenario analysis for quantifying risk, 298–300
- sensitivity analysis for quantifying risk, 300–302
- summary and references, 311–312
- Program evaluation and review technique (PERT), for group scheduling, 942
- Programmable logic controller (PLC), 667
- Project engineers, uses of P&IDs, 25
- Proportional-integral-derivative (PID), 625–626
- Proportional-integral (PI), 625
- Proprietary knowledge, business codes of conduct, 881
- PSM (Process Safety Management)
 - coordination with EPA Risk Management Program, 896
 - OSHA standard for chemical hazards, 893–894
- Pumps
 - analyzing ability to handle scale up, 697
 - bare module factors in costs, 1028
 - cost curves for purchased equipment, 1011
 - cost equation for purchased equipment costs, 1007
 - fluid system components, 720
 - heuristics for, 346
 - input/output model for, 687–688
 - material factors in costs of, 1027
 - Net Positive Suction Head (NPSH), 723–727
 - performance curves, 714–717
 - positive displacement pumps, 723
 - pressure factors in costs of, 1023
 - selecting equipment parameters in PFD synthesis, 395
 - specifying fluid type and conditions, 660
 - troubleshooting cumene process feed section, 829–831
- Purity
 - considerations relating to when to purify the feed, 654–655
 - controlling product purity in distillation columns, 654–655
- PVR (Present value ratio), in project evaluation, 275–277
- Q**
- Quadratic programming (QP)
 - defined, 452
 - in NLP optimization study, 582–583
 - solving linear MPC problems, 670
- Quality, considerations in deciding to use continuous or batch processes, 51
- Quality control, as focus of statistical process control, 669–670
- Quasi-Newton method
 - applying to thermodynamic properties, 554
 - Broyden's method as, 571
 - equation-oriented (EO) approach and, 577
- R**
- Random numbers, probability distribution and, 306
- Rate equations, for fluid flow, heat transfer, mass transfer, and chemical reactors, 698
- Rate of return on investment (ROROI)
 - establishing acceptable levels, 282–283
 - interest rate-related criteria in project evaluation, 272
 - nondiscounted methods for incremental analysis, 289–291
- Ratio control system
 - advantages/disadvantages of, 655–656
 - applying to water-gas shift (WGS) reactor, 656–657
- Raw material costs
 - efficiency of use and, 921
 - estimating, 223
 - example evaluating production of benzene via toluene HDA process, 228–229
 - example of, 205
 - in formula for COM, 205
 - list of common chemicals and their costs and shipping methods, 224
 - reasons for not operating at design conditions, 707
- Raw materials
 - efficiency of use, 65–66
 - methods for recycling unreacted, 66–67
 - price of commodity chemicals, 115
 - purifying prior to recycling, 71
- RCRA (Resource Conservation and Recovery Act), 896, 917
- REACH (Registration, Evaluation, Authorization and Restriction of Chemicals), 891
- Reactants
 - evaluating excess in feed, 154
 - excess affecting recycle structure, 71
 - tracing, 126
- Reaction kinetics
 - effects observed in, 787
 - factors in reactor performance, 785
 - reaction rate and, 788–790
- Reaction products. See Product chemicals
- Reaction rate
 - considerations in deciding to use continuous or batch processes, 53
 - impact of pressure on, 695–696
 - impact of temperature on, 752–753, 790
 - reaction kinetics and, 788–789
- Reaction vessel. See also Vessels
 - draining and filtering catalyst, 90
 - preheating, 88–89
 - reactions in, 89–90
- Reactions. See Chemical reactions
- Reactor block, in BFDs, 59
- Reactor feed preparation block, in BFDs, 58
- Reactor performance
 - comparing PFR and CSTR reactors, 791–796
 - heat transfer in chemical reactors, 796–799
 - increasing acetone production, 809–812
 - key performance relationships, 694
 - overview of, 785–786
 - parameters in, 785
 - production of desired product, 786–788
 - reaction kinetics, 788–790
 - replacing catalytic reactor in benzene process, 800–804
 - replacing cumene catalyst, 804–808
 - review questions and problems, 813–817
 - summary and references, 812–813
 - thermodynamic limitations, 790–791
- Reactors
 - bare module factors in costs, 1033
 - conditions of special concern for, 140
 - configurations for optimization of, 466–467
 - control system for water-gas shift (WGS) reactor, 656–657
 - cost curves for purchased equipment, 1020
 - cost equation for purchased equipment costs, 1007
 - cumene reactor regulation case study, 671–672
 - designing equipment for multiproduct processes, 107–109
 - dynamic models for, 616–617
 - equipment-dependent and equipment-independent relationships, 689–690
 - evaluation of, 151–156
 - heuristics for, 354
 - how many required, 71
 - ignition in, 378
 - impact of unwanted product or inert on operation of, 72
 - increasing conversion in, 753
 - increasing reaction rate in, 752–753
 - input/output example, 75
 - key performance relationships, 694
 - parameters in performance, 785

- Reactors (*continued*)
 performance of reactor/heat transfer combination, 749–752
 rate equations for, 698
 reaction vessel and, 89–90
 reasons for operating at pressure ranges of special concern, 144–145
 reasons for operating at temperature ranges of special concern, 143–146
 selecting equipment parameters in PFD synthesis, 396
 tracing reactants and product and, 126
 transformation of feed chemicals into product chemical, 127
- Reactors, synthesizing PFD from BFD
 base case configuration, 360
 feed preparation, 377–378
 questions to ask for reactor configuration, 360–361
- Reboilers. See also Boilers
 debottlenecking strategies for, 758
 distillation columns requiring, 754
 reboiler performance impacting distillation column performance, 756–757
- Reciprocating pumps, 723
- Recommended exposure limits (RELs), air contaminant standard, 890
- Recommended Practices, American Petroleum Institute, 893
- Recycle block, in BFDs, 59
- Recycle streams
 categories of, 687
 considerations regarding phase of, 72–73
 identifying in toluene HDA example, 132–135
 input/output diagram for, 686
 number of potential, 70–71
 PFD synthesis and, 378, 401–403
 tracing chemical species in flow loops, 132
- Recycle structure
 combining recycle of feed and product, 67–70
 efficiency of raw material usage and, 65–66
 example illustrating, 73–78
 issues related to, 70–73
 methods for recycling unreacted raw materials, 66–67
 overview of, 64
- Recycling
 in green engineering, 921
 regulations in Pollution Prevention Act of 1990, 916
- Reflection in action, self inspection of professional ethics, 858–859
- Reflux Ratio, in optimization example, 470–473
- Refrigeration
 estimating utility costs, 215–218
 heuristics for, 355
 utilities provided off-site, 212
- Registration, Evaluation, Authorization and Restriction of Chemicals (REACH), 891
- Regulating chemical processes. See Controlling/regulating chemical processes
- Regulations/agencies
 air contaminants standard (OSHA and NIOSH), 890
 emergency release of emissions, 895–896
 Environmental Protection Agency (EPA), 894
 EPA Risk Management Plan (RMP), 896–897
 Hazard Communication Standard (HazCom), 890–891
 minimum MSDS requirements, 891–892
 nongovernmental organizations (NGOs), 897–898
 Occupational Safety and Health Administration Act of 1970, 889
 OSHA and NIOSH, 889
 overview of, 888–889
 planned emissions, 894–895
 Process Safety Management of Highly Hazardous Chemicals, 892–893
 Process Safety Management (PSM), 893–894
- Registration, Evaluation, Authorization and Restriction of Chemicals (REACH), 891
- Rehearsal, of new skills, 857–858
- Relief valves, in pressure-relief systems, 900
- RELs (Recommended exposure limits), NIOSH air contaminant standard, 890
- Reports, in troubleshooting strategy, 823–824
- Residual cost, in capitalized cost method, 284
- Residue curves
 boundaries on, 376–377
 for ternary azeotropic distillation, 372–374
- Resource Conservation and Recovery Act (RCRA), 896, 917
- Response surface techniques
 parametric optimization and, 478
 vs. lattice search, 478
- Responsible Care program, 898
- Retrofitting
 capital cost methods, 292
 debottlenecking and, 840
 discounted method for incremental analysis, 291–292
 incremental analysis for, 289
 nondiscounted method for incremental analysis, 289–291
 operating cost methods, 292–293
- Return, on investment, 458
- Reverse solubility, of magnesium and calcium salts, 218–219
- Rigorous module, designing distillation columns and, 397–398
- Risk
 forecasting uncertainty, 294–298
 overview of, 293–294
 quantifying, 298
 relationship to rate of return, 282–283
 scenario analysis for quantifying, 298–300
 sensitivity analysis for quantifying, 300–302
- Risk assessment
 accident statistics, 886–887
 chemical engineer's role in, 888
 overview of, 886
 worst-case scenarios, 887–888
- Roles and responsibilities, groups and, 940
- Runaway reactions, 797, 899–900
- Runge-Kutta methods, 621–622
- Rupture disks, in pressure-relief systems, 900
- S**
- S&T exchangers. See Shell-and-tube (S&T) exchangers
- Safety. See also Health, safety, and environment (HSE)
 considerations in deciding to use continuous or batch processes, 53
 considerations relating to when to purify the feed, 60–61
 simulation in training for, 41–43
 of work environment, 933
- Safety valves, in pressure-relief systems, 900
- Salvage value, depreciation and, 254–255
- SARA (Superfund Amendments and Reauthorization Act), 895–896
- Savings, banks and, 236
- Scale models, types of auxiliary diagrams used in process design, 27
- Scenario analysis, for quantifying risk, 298–300
- Scheduling
 batch processes, 93–94
 group tasks, 942–943
 Scientists, interactions among, 358
- Scope (Preliminary Design), in cost estimation, 164–165
- Screens
 bare module factors in costs, 1033
 cost curves for purchased equipment, 1020
 cost equation for purchased equipment costs, 1007
- Scrubbers, in pressure-relief systems, 900
- Selectivity
 conversion and, 788
 cumene catalyst, 807
 reactor design and, 361
 reasons for operating at conditions of special concern, 146
- Sensitivity analysis
 decision variables and, 583
 in process optimization, 479
 for quantifying risk, 300–302
 steady-state simulators used in, 581
- Sensitivity coefficient, 301
- Separate and purify
 approaches to recycling unreacted raw materials, 65–66
 in input/output example, 75
- Separation
 conditions of special concern for, 140
 distillation in. See Distillation
 electrolyte applications, 416
 guidelines for choosing and for sequencing separation units, 363

- guidelines for choosing separation operations, 362–364
- McCabe-Thiele diagram for, 734–736
- optimization of, 466–467
- PFDs and, 78
- removing trace contaminants from, 921
- using mass separating agents, 728–733
- Separator block, in BFDs, 59
- Separator feed preparation block, in BFDs, 59
- Separators
 - dynamic simulation of flash separators, 614–616
 - evaluating high-pressure phase separator, 156
 - key performance relationships, 694
 - reasons for operating at pressure ranges of special concern, 144–145
 - reasons for operating at temperature ranges of special concern, 144
 - vapor phase as reason for operating at conditions of special concern, 146
- Separators, synthesizing PFD from BFD
 - azeotropic distillation, 367–368
 - azeotropic distillation in binary systems, 368–370
 - azeotropic distillation in ternary systems, 370–377
 - feed preparation, 377–378
 - guidelines for choosing separation operations, 362–364
 - overview of, 362
 - simple distillation, 364–367
- Sequencing, batch process design and, 87
- Sequential Function Chart (SFC), 667
- Sequential modular (SM) approach, to steady-state simulation
 - accelerated successive substitution (or relaxation) methods, 569–570
 - Broyden's method, 571
 - direct substitution algorithm, 569
 - dominant eigenvalue method (DEM), 570
 - examples, 571–576
 - overview of, 562–569
 - SMod approach as hybrid of SM and EO, 578
 - types of simulators, 388–389
 - Wegstein's method, 570–571
- Sequential quadratic programming (SQP), in NLP optimization study, 582–583, 586
- Series reactions, reaction kinetics, 787
- Set point (SP)
 - feedback control system and, 649
 - process control in dynamic simulation, 625
- SF (Stream factors), in calculation of yearly costs, 225
- SFC (Sequential Function Chart), 667
- Shell-and-tube (S&T) exchangers. *See also* Heat exchangers
 - effectiveness factor (F) and, 520–526
 - performance curves, 711
 - reducing heat generated by exothermic reactions, 750
- Shewart chart, for statistical process control, 670
- Shock wave, in explosions, 899
- Short-term exposure limit (STEL), measuring exposure to hazardous chemicals, 890
- Shortcut methods, experience-based principles in process design, 332–333
- Shortcut module, designing distillation columns and, 397
- SI units, in diagramming, 27
- Simple distillation, 364–367
- Simple interest
 - rate of, 235
 - types of interest, 238
- Simple savings, 234
- Simulations
 - augmented reality (AR) and, 41–42
 - of chemical processes, 37–38
 - dynamic. *See* Dynamic simulators
 - immersive training simulators (ITS), 38–40
 - operator training simulators (OTS), 38
 - output display options, 400
 - setting up problem on simulator, 387
 - synthesizing PFD using simulator. *See* Synthesis of PFD, using simulator
 - training for emergencies, safety, and maintenance, 41–43
- Simulators
 - commercially available, 385
 - dynamic. *See* Dynamic simulators
 - expert systems, 391
 - features of, 386
 - physical property databanks, 390
 - setting up problem on, 387
 - steady-state. *See* Steady-state simulators
 - structure, 386–389
 - types of, 388–389
 - what they do, 385–386
- Simultaneous methods, solutions to DAE systems, 619
- Simultaneous modular (SMod) approach
 - comparing approaches to tear convergence, 579–580
 - to optimization, 583–586
 - to steady-state simulation, 578–581
 - types of simulators, 388
- Simultaneous nonmodular approach, 388
- Single-input-single-output (SISO) controllers, in dynamic simulation, 625
- Single pass conversion
 - of reactant, 787
 - reactor design and, 361
 - vs. overall conversion, 65–66
- Single reaction, reaction kinetics, 787
- Single-variable example, of parameter optimization, 468–470
- SISO (single-input-single-output) controllers, in dynamic simulation, 625
- Site plans, 27
- Six-tenths rule
 - applying to cost of scaling up equipment, 169–170, 174
 - cost ratios using, 169
- Skills, rehearsal of new, 857–858
- SLE (Solid-liquid equilibrium), 429
- SM approach. *See* Sequential modular (SM) approach, to steady-state simulation
- SMod approach. *See* Simultaneous modular (SMod) approach
- Soave-Redlich-Kwong (SRK) fugacity model, 404–406
- Societal impact, of chemical engineering design, 853–855
- Software
 - PDMS software, from Cadcentre, 35
 - for virtual plant walkthrough, 27
- Soil sorption coefficient, properties impacting environment fate of chemicals, 918
- Solid-liquid equilibrium (SLE), 429
- Solid-vapor equilibrium (SVE), 430
- Solid wastes, in estimating manufacturing costs, 228
- Solids modeling
 - overview of, 429
 - parameters, 431–434
 - physical properties, 429–431
- Solvents, additions required to be added to feed, 61
- Sour-water stripper (SWS), creating simulation model for, 424–428
- Source reduction regulation, in Pollution Prevention Act of 1990, 915–916
- SOYD (Sum of the years digits depreciation method), 255
- SP (Set point)
 - feedback control system and, 649
 - process control in dynamic simulation, 625
- SPC (Statistical process control), controlling/regulating chemical processes, 669–670
- Special process hazards factor, in Dow Fire & Explosion Index, 906
- Specialty chemicals, in chemical industry, 115
- Split-range control system
 - applying temperature control to tempered-water system, 658–659
 - controlling Ethylene Oxide production, 659–660
 - overview of, 657
 - strategies and advantages/disadvantages, 658
- Splitters
 - operations in tracing chemical pathways, 125–126
 - selecting equipment parameters in PFD synthesis, 395–396
 - tracing chemical pathways, 125–126
- SQP (Sequential quadratic programming), in NLP optimization study, 582–583, 586
- SRK (Soave-Redlich-Kwong) fugacity model, 404–406
- ST (Structured Text) logic control, 667
- Stack, in pressure-relief systems, 900
- Stainless steel, selection of materials of construction, 186
- Standardization of equipment, considerations in deciding to use continuous or batch processes, 51–52

- State government, rules for health, safety, and environment, 888–889
- State (phase). See Phase (state)
- State variables
challenges of dynamic simulation, 603
defined, 601
- Statistical process control (SPC), controlling/regulating chemical processes, 669–670
- Steady-state material balance, maintaining during process control, 642–643
- Steady-state simulators
accelerated successive substitution (or relaxation) methods, 569–570
Broyden's method, 571
direct substitution algorithm, 569
dominant eigenvalue method (DEM), 570
dynamic simulators compared with, 602
equation-oriented (EO) approach, 576–578
estimating physical property parameters, 586–589
examples of SM approach, 571–576
examples of studies using, 584–586
need for, 552
operator training simulators (OTS), 37–38
optimization studies using, 581–583
ordinary differential equations (ODEs), 617
overview of, 551
review questions and problems, 591–599
sensitivity studies using, 581
sequential modular (SM) approach, 562–569
simultaneous modular (SMod) approach, 578–581
solution strategy, 562
summary and references, 589–591
topological changes in adapting for dynamic simulation, 603–607
user-added models (UAM) and, 552–553
user-added unit operation models (UAUOM), 553–555
user kinetic models, 558–562
user thermodynamic and transport models, 555–558
Wegstein's method, 570–571
- Steam
base-case ratios applied to steam properties, 697
cost of high-pressure steam, 220–221
cost of low-pressure steam, 222
cost of medium-pressure steam, 221–222
determining steam balance for new facility, 219–220
energy balance with boiler feed water, 763
estimating cost of producing, 218–220
evaluating control valves, 157
regulating utility streams in chemical plants, 662–664
temperature limits associated with heating/cooling steam, 142
traps on process heater, 664
troubleshooting steam release in cumene reactor, 833–835
utilities provided off-site, 212
utility cost estimation from PFD, 226–228
- Steam boilers/generators. See also Boilers
determining capacity of, 220
energy balance with boiler feed water, 763
performance curves for, 709, 712–713
- Stefan-Maxwell equation, in thermodynamics, 555
- STEL (Short-term exposure limit), measuring exposure to hazardous chemicals, 890
- Stiff problems, 619–620
- Stoichiometric reactors, selecting equipment parameters in PFD synthesis, 396
- Storage
intermediate, 104–106
for single-product campaigns, 102–104
- Storage vessels
cost curves for purchased equipment, 1015
dynamic simulation and, 614–616
heuristics for, 345
schematic of, 668
- Storming stage, in group evolution, 941
- Straight-line depreciation, 255, 261
- Stream factors (SF), in calculation of yearly costs, 225
- Streams
bypass streams, 132
categorization of information in PFDs, 12–15
combining topology, stream data, and control strategy, 18–21
feed streams. See Feed chemicals/feed streams
information regarding in PFDs, 8
input/output structure and, 55–56
phase changes and pinch technology and, 530–532
process streams. See Process streams
purifying unreacted raw material streams prior to recycling, 71
recycle streams. See Recycle streams
recycling feed and product together via purge stream, 67–68
tactics for tracing chemical species and, 126–127
tear streams in. See Tear streams
utility streams. See Utility streams
waste streams, 462–463
- Strippers
creating model for sour-water stripper (SWS), 424–428
selecting equipment parameters in PFD synthesis, 399
- Structural support diagrams, 27
- Structure-mounted vertical arrangement, plant layout, 28, 30
- Structured Text (ST) logic control, 667
- Studies, using steady-state simulators
examples, 584–586
optimization studies, 581–583
sensitivity studies, 581
- Study (Major Equipment or Factored)
estimate, classification of cost estimates, 164–165
- Substitution, in inherently safe design, 909
- Sum of the years digits depreciation method (SOYD), 255
- Superfund Amendments and Reauthorization Act (SARA), 896
- Supply and demand, in chemical markets, 295–298
- Surface tension
creating model for sour-water stripper (SWS), 426
in modeling electrolyte systems, 422–423
Onsager-Samaras Law, 438
- Survival, in inherently safe design, 910
- SVE (Solid-vapor equilibrium), 430
- SWS (Sour-water stripper), creating simulation model for, 424–428
- Symbols
ASME set of, 9
for use in PFDs, 11
- Symptoms
identifying in troubleshooting strategy, 823–824
steps in process troubleshooting, 820
- Synergy, group efficiency and, 932, 934
- Synthesis, 327
- Synthesis of PFD, from BFD
azeotropic distillation, 367–368
azeotropic distillation in binary systems, 368–370
azeotropic distillation in ternary systems, 370–377
environmental control section, 378–379
equipment summary table, 380
flow summary table, 379–380
guidelines for choosing separation operations, 362–364
information needed and sources, 358–360
overview of, 357
process control loops, 379
reactor and separator feed preparation, 377–378
reactor section, 360–361
recycle section, 378
review questions and problems, 382–384
separator section, 362
simple distillation, 364–367
summary and references, 380–381
- Synthesis of PFD, using simulators
applying thermodynamic models, 412–413
building model of aqueous electrolyte system, 423–429
building model of distillation column for electrolyte system, 437–440
chemical component selection, 389–390
chemical equilibrium in modeling electrolyte systems, 420
convergence criteria for simulation, 400–401
diffusion coefficient in modeling electrolyte systems, 421–422
electrolyte systems modeling, 416–419
enthalpy model, 404

- equipment parameters, 393–400
 - feed stream properties, 393
 - flowsheet topology, 392–393
 - Gibbs energy calculation for electrolyte systems, 434–437
 - heat capacity in modeling electrolyte systems, 419–420
 - information needed (input data), 389
 - molar volume in modeling electrolyte systems, 420
 - output display options, 400
 - overview of, 385–386
 - parameters for solids model, 431–434
 - phase equilibrium, 405–412
 - physical properties related to solids modeling, 429–431
 - physical properties related to thermodynamics, 404
 - physical property models, 390–392
 - recycle streams, 401–403
 - review questions and problems, 444–450
 - selecting thermodynamic models, 403–404
 - solids modeling, 429
 - structure of process simulators, 386–389
 - summary and references, 441–444
 - surface tension in modeling electrolyte systems, 422–423
 - thermal conductivity in modeling electrolyte systems, 421
 - toluene HDA case study, 414–416
 - viscosity in modeling electrolyte systems, 420–421
 - Synthesis pathways, finding new pathways in green engineering, 920
 - System curves. See also Performance curves
 - centrifugal pumps, 714–717
 - defined, 718
 - friction losses and, 700–702
 - System pressure drop, 722
- T**
- T-Q* diagrams, for heat exchangers, 702–704
 - Tanks. See also Vessels
 - cost curves for purchased equipment, 1015
 - cost equation for purchased equipment costs, 1007
 - pressure factors in costs of, 1024
 - reducing emissions related to storage tanks, 921–922
 - Task differentiation, in groups, 932–933
 - Taxation
 - after tax cash flow diagram, 269
 - depreciation and, 258
 - example calculating, 260–261
 - impact of tax rate on profit, 259–260
 - Teams. See also Groups
 - characteristics of, 944–945
 - learning in, 946–947
 - misconceptions, 945–946
 - resource materials for, 947–948
 - review questions and problems, 949–950
 - summary and references, 948–949
 - when groups become teams, 943–944
 - Tear streams
 - comparing methods for, 574
 - in sequential modular approach, 562, 565–568
 - simulation algorithms applied to tear stream convergence, 571
 - Technology, evaluating risks associated with new technology, 308–310
 - Temperature
 - adjusting vs. changing composition of, 140
 - composite temperature-enthalpy diagram, 514–516
 - effect of ambient conditions on dynamic models, 608–609
 - evaluating process conditions of reactors, 153, 155–156
 - heat transfer and, 703
 - impact on reaction rate, 752–753, 790, 792
 - impacting bare module equipment costs, 182–184
 - limits associated with heating/cooling, 142
 - limits that affect chemical processes (400°C rule), 141
 - measurement of process variables, 649
 - in MUMNE problem, 503
 - pinch temperature, 504
 - reactor design and, 360
 - reasons for multiple reactors, 71
 - reasons for operating at conditions of special concern, 143–144
 - regulating temperature driving force between process fluid and utility, 665–666
 - thermodynamic limitations on conversion, 790–791
 - troubleshooting cumene reactor, 839
 - troubleshooting packed-bed absorber, 827
 - Tensile strength, impact of temperature on, 141
 - Texas A&M, engineering ethics at, 871
 - Thermal conductivity
 - building model of distillation column for electrolyte system, 439
 - creating model for sour-water stripper (SWS), 426
 - gathering physical property data for PFD design, 359
 - in modeling electrolyte systems, 421
 - physical properties related to thermodynamics, 404
 - Thermal insulation, heuristics for, 349
 - Thermal systems, utilities provided off-site, 212
 - Thermodynamic models
 - alternative models, 411–412
 - applying, 412–413
 - building model of distillation column for electrolyte system, 437–438
 - complex or difficult systems, 410–411
 - creating model for sour-water stripper (SWS), 426
 - data use in crude calculations, 410
 - enthalpy model, 404
 - hybrid systems, 411
 - liquid-state activity-coefficient models, 407–410
 - need for steady-state simulation, 552
 - phase equilibrium, 405–406
 - physical properties, 404
 - selecting, 403–404
 - simulator in solving, 387
 - user models, 555–558
 - Thermodynamics
 - evaluation of reactors, 151
 - limitations impacting reactor performance, 790–791
 - limits associated with laws of, 499
 - Threshold limit values (TLV), air contaminant standards, 890
 - Time
 - in calculating compound interest, 240
 - cash flows adjusted for point in time, 245
 - inflationary trends in capital costs over time, 171–172
 - interest rates changing over, 239
 - Time criteria
 - discounted profitability criteria in project evaluation, 275
 - profitability criteria in project evaluation, 271
 - Time value of money
 - cash flows adjusted for point in time, 245
 - investments and, 237
 - Time-weighted average (TWA), measuring exposure to hazardous chemicals, 890
 - Titanium (and its alloys), selection of materials of construction, 189
 - TLV (Threshold limit values), air contaminant standards, 890
 - Tolerance, convergence criteria for simulation, 400
 - Toluene HDA process
 - distillation of benzene from, 754
 - equipment summary in PFD for, 17–18
 - evaluating production of benzene via, 228–229
 - input/output models for, 690–691
 - primary flow paths for toluene and benzene, 127–129
 - primary path flows for hydrogen and methane, 130–132
 - producing benzene via, 17–19
 - recycle and bypass streams, 132–135
 - synthesizing PFD using simulator, 414–416
 - Top-down strategies, in process optimization, 455–456
 - Topological optimization
 - alternatives for separation and reactor configuration, 466–467
 - eliminating equipment, 463–464
 - eliminating unwanted hazardous by-products, 462–463
 - overview of, 461
 - rearranging equipment, 464–466
 - Topology, steady-state simulation of, 603–607
 - Total capital for depreciation, 255
 - Total module costs, 193–195

- Towers
 bare module factors in costs, 1028, 1032
 cooling water facility (tower), 211–215
 cost equation for purchased equipment costs, 1007
 heuristics for, 350, 352
 pressure factors in costs of, 1024
- Toxic Substances Control Act (TSCA), 896
- Toxins, considering when to purify the feed, 60–61
- Tracing chemical components. See Chemical components, tracing in PFD
- Training
 immersive training simulators (ITS), 38–40
 operator training simulators (OTS), 38
 simulation in training for emergencies, safety, and maintenance, 41–43
 using P&IDs in operator trainings, 25–26
- Transport models
 building model of distillation column for electrolyte system, 438–439
 user transport models, 555–558
- Trays
 bare module factors in costs, 1028, 1032
 cost curves for purchased equipment, 1014
 cost equation for purchased equipment costs, 1007
 pressure factors in costs of, 1024
- Trends
 equations for analysis of, 694
 predicting, 695–696
- Troubleshooting
 acrylic acid product, 831–833
 cumene process feed section case study, 829–831
 debottlenecking, 840
 entire process, 836–840
 methodology for, 821
 multiple units, 831
 overview of, 819–821
 packed-bed absorber case study, 825–829
 problem-solving strategies, 821–823
 review questions and problems, 841–851
 steam release in cumene reactor, 833–835
 steps in, 820, 823–825
 summary and references, 841
- TSCA (Toxic Substances Control Act), 896
- Turbines
 cost equation for purchased equipment costs, 1007
 pressure factors in costs of, 1024
- TWA (Time-weighted average), measuring exposure to hazardous chemicals, 890
- Two-variable example, of parameter optimization, 470–473
- Tyreus-Luyben tuning rule, 626–629
- U**
- UAUOM (User-added unit operation models), 553–555
- UEL (upper explosive limit), 898
- UFL (upper flammability limit), 898
- Uis (Unlimited intermediate storage), 104
- Undesirable products. See By-products
- UNIFAC liquid-state activity-coefficient model, 409–410
- Unit operation block solver, simulator features, 387
- Unit operations
 identifying problem area in troubleshooting strategy, 823–824
 performance curves by. See Performance curves
 performance of multiple unit operations. See Performance, of multiple unit operations
 troubleshooting multiple, 831
- Unlimited intermediate storage (uis), 104
- Unstable systems, uses of dynamic simulation, 603
- Upper explosive limit (UEL), 898
- Upper flammability limit (UFL), 898
- U.S. Coast Guard, regulating transport of hazardous chemicals, 896
- User-added models (UAM)
 overview of, 552–553
 user-added unit operation models (UAUOM), 553–555
 user kinetic models, 558–562
 user thermodynamic and transport models, 555–558
- User-added unit operation models (UAUOM), 553–555
- Utilities
 conventions used in drawing P&IDs, 22
 design combining with minimum number of exchangers with minimum number of utilities, 500
 exchanging heat between process streams and utilities, 662–665
 heaters/coolers in dynamic simulation, 609–612
 heuristics for utility specification, 355
 multiple utilities and pinch technology, 530
 reactor design and, 360
 regulating temperature driving force between process fluid and utility, 665–666
 solving minimum utility (MUMNE) problem, 502–508
- Utility costs
 background of, 209–211
 calculating, 211
 cooling tower water, 211–215
 estimating from PFDs, 225–228
 evaluating production of benzene via toluene HDA process, 228–229
 in formula for COM, 205
 heating heat-transfer fluids, 223
 high-pressure steam, 220–221
 low-pressure steam, 222
 medium-pressure steam, 221–222
 refrigeration, 215–218
 steam production, 218–220
 waste heat boilers, 223
- Utility flowsheets, 27
- Utility streams
 headers in supply of, 641–642
 heat and work and, 687
 identifying stream information in PFDs, 12–13
 information regarding in PFDs, 8
 input/output diagram for, 686
 input/output structure and, 55–57
 primary types in chemical plants, 662–663
 suppliers, 211
- V**
- Vacuum pumps, heuristics for, 347
- Valves
 binary distillation column case studies, 673–675
 evaluating pressure control valves, 157
 feedback control in cumene reactor example, 672
 flowrate control with, 641–642
 fluid system components, 720
 reasons for operating at conditions of special concern, 147
 role in flowrate regulation, 643–646
 selecting equipment parameters in PFD synthesis, 396
 terminating control loops, 25
- Vapor cloud explosions (VCEs), 899
- Vapor-Liquid equilibrium (VLE)
 constraints, 587
 creating model for sour-water stripper (SWS), 426
 electrolyte models and, 417
 gathering physical property data for PFD design, 359–360
 liquid-state activity-coefficient model applied to, 408
 vapor phase as reason for operating at conditions of special concern, 146
- Vapor phase, reasons for operating at conditions of special concern, 146
- Vapor pressure, properties impacting environment fate of chemicals, 918
- Vaporizers
 bare module factors in costs, 1028, 1030–1031
 cost curves for purchased equipment, 1010
 cost equation for purchased equipment costs, 1007
 pressure factors in costs of, 1024
- Variable optimization. See Parametric optimization
- Variables
 inputs. See Input variables (inputs) manipulated. See Manipulated variables (MVs)
 measurement of, 649
 multivariable interactions, 669
 outputs. See Output variables (outputs) state variables, 601, 603
 types of, 601
- VB (Visual Basic), 553
- VCEs (Vapor cloud explosions), 899

- Vessels. See also Tanks
auxiliary diagrams used for, 27
bare module factors in costs, 1028
conservation equations applied to equipment geometry and size, 607–608
cost curves for purchased equipment, 1015
cost equation for purchased equipment costs, 1007
costs of materials of construction, 189–190
dynamic simulation of flash separators and storage vessels, 614–616
example of pressure-flow in flash vessel, 604–606
heuristics for, 344–345
material factors in costs of, 1026
pressure factors in costs of, 184, 1021, 1023
reaction vessel. See Reaction vessel
schematic of storage vessel, 668
- Virtual reality, for plant walkthrough, 27, 35
- Viscosity
creating model for sour-water stripper (SWS), 426
gathering physical property data for PFD design, 359
Jones-Dole model for, 438–439
in modeling electrolyte systems, 420–421
physical properties related to thermodynamics, 404
- Visual Basic (VB), 553
- VLE. See Vapor-Liquid equilibrium (VLE)
- VOCs (Volatile organic compounds), EPA regulations, 895
- Volatile organic compounds (VOCs), EPA regulations, 895
- W**
- Waste heat boilers. See also Boilers, 223
- Waste management, Pollution Prevention Act of 1990 and, 915
- Waste streams, eliminating unwanted hazardous by-products, 462–463
- Waste treatment
activated sludge in, 379
in estimating manufacturing costs, 228
regulations in Pollution Prevention Act of 1990, 916
utilities provided off-site, 212
- Waste treatment costs
evaluating production of benzene via toluene HDA process, 229
example of, 205
in formula for COM, 205
- Wastewater treatment
electrolyte applications, 416
utilities provided off-site, 213
- Water
EPA water quality standards, 895
filtering water used for steam production, 218–219
utilities provided off-site, 212
- Water-gas shift (WGS) reactor, 656–657
- Wegstein's method
applied to tear stream convergence, 571, 574
comparing approaches to tear convergence, 579–580
steady-state algorithm, 570–571
- What-if technique, in Process Hazard Analysis requirement, 901
- Whistle-blowing, 865, 868–870
- Wilson liquid-state activity-coefficient models, 409–410
- Wiring diagrams, 27
- Work environment, groups and, 933–934
- Work, utility streams and, 687
- Worker Right to Know regulations, 890
- Working capital, depreciation of, 254
- Worst-case scenario
required in EPA hazard assessment, 897
studies in risk assessment, 887–888
- Y**
- Yearly depreciation, 255
- Yearly operating cost (YOC)
evaluating profitability of equipment with different operating lives, 285
stream factors in calculation of, 225
- Yield, of desired product of reaction, 788
- Z**
- Zero wait (zw) batch process, intermediate storage and, 104
- Ziegler-Nichols stability margin controller tuning rule, 626–629