

Piezoresistive pressure transmitter

for Test & Measurement applications

Type 4262A...

The modular high performance pressure transmitters of the Type 4262A series are characterized by high accuracy and excellent long-term stability, even in harsh environments with high temperature extremes, high vibration and shock loads.

- Gauge / relative pressure
- Pressure ranges from 0.1 to 350 bar (1.5 to 5,000 psi)
- Comp. Temp. range -40 ... 120°C (-40 ... 250°F)
- Dynamic pressures up to 2 kHz
- Accuracy 0.1% FS
- Stability per year 0.1% FS
- Proof pressure 300%
- Wide choice of pressure & electrical connections
- Electrical output options mV, V and mA
- Hazardous area certification (optional)

Description

The piezoresistive gauge pressure transmitters of the Type 4262A series can be used for a variety of applications where static as well as dynamic pressures up to 2 kHz need to be measured.

At the core of the Type 4262A series there is a silicon sensing element mounted within a high integrity seal assembly that is fully isolated from the pressure media by a welded 316L stainless steel diaphragm. The pressure to be measured acts on the sensor's diaphragm and is transferred through incompressible silicone oil to a micro machined silicon strain gauge configured as a Wheatstone bridge. The advantages of silicon, compared with metal, based strain gauge pressure sensors is their higher sensitivity, better repeatability, higher signal to noise ratio, higher overload and a significantly higher long-term stability. The pressure sensing assembly features a unique sealing method (US Patent 7,373,827) that enables the sensor to withstand multiple cycles without fatigue. This design also enables flexibility in choice of pressure connections without the use of adaptors or O-rings.

Built in electronics condition the output from the silicon sensing element, provide for temperature compensation, EMC protection, reverse polarity, power supply regulation, over voltage, short circuit protection and configure the electrical output for a wide choice of voltage or mA outputs.

Finally, every Type 4262A transmitter is fully tested over both pressure and temperature to ensure compliance to the specifications. This data is available for each sensor and is traceable to ISO 17025 and NIST.



Applications

Type 4262A series from Kistler is well suited for demanding pressure applications in the R&D, engine test, road test, component test and other test applications supporting the automotive, aerospace and industrial markets.

Engine and powertrain test

- Engine oil and coolant pressures
- Engine fuel
- Inlet and exhaust pressures
- Barometric pressure
- Transmission pressures



On-vehicle test

- Engine oil and coolant pressures
- Engine fuel
- Inlet and exhaust pressures
- Air conditioning
- Brakes and hydraulics

Component, sub-system and system testing

- Auxiliary power units
- Air conditioning systems
- Fuel, water and oil pumps
- Suspension systems
- ABS test stands
- High pressure fuel control systems
- Ground and flight test
- Leak testing
- Environmental monitoring & control
- Piping systems

General technical data

| Type | Unit | 4262A... | |
|--|-----------------|--|---|
| Pressure range | unidirectional | barG barS | 0.1 / 0.17 / 0.2 / 0.35 / 0.5 / 0.7 / 1 / 1.7 / 2 / 3.5 / 4 / 5 / 7 / 10 / 14 / 20 / 35 50 / 70 / 100 / 140 / 200 / 350 |
| | | psiG psiS | 1.5 / 2.5 / 3 / 5 / 7.5 / 10 / 15 / 25 / 30 / 50 / 60 / 75 / 100 / 150 / 200 / 300 / 500 750 / 1,000 / 1,500 / 2,000 / 3,000 / 5,000 |
| | compound | barG psiG | 1 / 1.7 / 2 / 4 / 7 / 9 / 16 / -0.2 ... 0.3 / -0.07 ... 1 15 / 25 / 30 / 60 / 100 / 130 / 230 / -3 ... 4.5 / -1 ... 15 |
| | | bidirectional | barG psiG |
| Proof pressure / Burst pressure | | >3xFS pressure / >4xFS pressure | |
| Output type | | mV, V or mA | |
| <i>Temperature limits</i> | | | |
| Compensated temperature ranges mV and V output | °C / °F | -40 ... 120 / -40 ... 250 | |
| | mA output | °C / °F | -40 ... 80 / -40 ... 175 |
| Operating | mV and V output | °C / °F | -55 ... 125 / -67 ... 255 |
| | mA output | °C / °F | -55 ... 80 / -67 ... 175 |
| Storage | mV and V output | °C / °F | -55 ... 125 / -67 ... 285 |
| | mA output | °C / °F | -55 ... 100 / -67 ... 212 |
| Accuracy @ 25°C (non-linearity, hysteresis, repeatability) | ± %BFSL | 0.2 (≤1 barG / 15 psiG) / 0.1 (>1 barG / 15 psiG) / 0.15 (350 barS / 5,000 psiS) | |
| <i>Thermal effects (reference @ 25°C)</i> | | | |
| -10 ... 50°C | %Span | 1.0 | |
| -40 ... 120°C (80°C for mA version) ¹⁾ | %Span | 1.5 | |
| Long term stability (12 months) | %Span | ±0.1 | |
| Design life | FS cycles | 50 million at 2 Hz | |
| Vibration, 50 g peak, 10 Hz to 2 kHz per | %FS/g | response <0.05 | |
| Shock | | MIL-STD-202G Method 204D, condition E | |
| | | 1,000 g, 0.5 ms half sine pulse in 3 mutually perpendicular axes will not affect performance MIL-STD-202G, Method 213B-1, condition E | |
| | | 100 g, 6 ms half sine pulse in 3 mutually perpendicular axes will not affect performance MIL-STD-202G, Method 213B-1, condition C | |
| Acceleration sensitivity | %FS/g | <0.05 (reducing with increasing pressure range) | |
| Insulation resistance, at 500 VDC | MΩ | 100 | |
| Approvals | | CE compliant to EN61326:2013 | |
| | | Pressure equipment directive 2014/68/EU (PED), cat. 1, pressure accessory | |
| | | RoHS compliant 2011/65/EU | |
| Hazardous area certification (optional) | | IS Zone 0 Ex ia IIC T4 Ga CE  II 1G (-40°C ≤Ta ≤80°C) / (-40°F ≤Ta ≤175°F) | |
| | | Non-incendive Zone 2 Ex nA IIC T4 Gc CE  II 3G (-40°C ≤Ta ≤80°C) / (-40°F ≤Ta ≤175°F) | |
| | |  CSA certified 2009 2053869 single seal | |
| | | Class I, Division 1, Groups A,B,C,D Ex ia IIC T4 / AEx ia IIC T4 (-40 to +80°C) / (-40 to +175°F) | |
| | | Class I, Division 2, Groups A,B,C,D Ex nL IIC T4 / AEx nA IIC T4 (-40 to +80°C) / (-40 to +175°F) | |
| Installation torque | N-m / lbf-ft | 15 / 11.1 | |
| Environmental protection | | IP65 ²⁾ | |
| Weight | grams / oz | <226 / <8 | |
| Media compatibility | material | Stainless steel 316L | |

4262A_003-388e-04_21

General electrical specifications

| | | | |
|---|---|-----|---|
| Supply voltage | | | |
| mV versions | VDC | | 5 ... 15 |
| Voltage versions | VDC | | refer to table voltage versions; electrical specs |
| mA versions | VDC | | 9 ... 28 |
| DC output impedance | Ω | | <200 (V output) |
| Minimum load resistance | Ω | | 2,500 (V output); 5,000 (-5 ... 5 V, 4-wire); 20,000 (-5 ... 5 V, 3-wire) |
| Supply voltage effects max. (regulated units) | %Span/V | | 0.005 |
| Warm up time | ms | | <1 (V output) <3 (mA output) |
| Output noise typical | mVrms | | <1 (V output), <0.1 (mA output) |
| Zero setting | mV versions | %FS | ± 3 |
| | V and mA versions | %FS | ± 1 |
| Span setting | mV versions | %FS | ± 3 |
| | V and mA versions | %FS | ± 1 |
| Frequency response, max. | Hz | | 2,000 |
| Options | non-interactive zero and span adjust | %FS | ± 5 |
| | Shunt calibration (Rcal), $\pm 20\%$ (V only) | %FS | 80 |

Voltage versions; electrical specifications

| V output type | Supply voltage (VDC) | Current drain (mA) |
|----------------------|----------------------|--------------------|
| 0.5 ... 4.5 / 3-wire | 5 ... 7 | 2.5 |
| -5 ... 5 / 3-wire | 13 ... 42 | 7 ... 16 |
| -5 ... 5 / 4-wire | 13 ... 42 | 6 ... 8.5 |
| 0 ... 5 / 3-wire | 7 ... 42 | 7 ... 16 |
| 0 ... 5 / 4-wire | 8 ... 42 | 3 ... 6 |
| 0.1 ... 5 / 3-wire | 8 ... 42 | 3 ... 6 |
| 1 ... 5 / 3-wire | 8 ... 42 | 3 ... 6 |
| 1 ... 6 / 3-wire | 8 ... 42 | 3 ... 6 |
| 0 ... 10 / 3-wire | 13 ... 42 | 7 ... 16 |
| 0 ... 10 / 4-wire | 13 ... 42 | 3 ... 6 |

Difference between vented and sealed gauge pressure transmitters

Gauge pressure transmitters measure pressures relative to atmospheric pressure and can be divided into two types; vented and sealed gauge transmitters. The two types can be determined by the suffixes barG/psiG (vented) and barS/psiS (sealed).

Vented gauge pressure transmitters

The reference pressure in a vented gauge transmitter allows atmospheric pressure in and out of an area behind the silicon sensing element through a vent tube located near the transmitter's electrical connector (hence the lower IP rating than sealed gauge type transmitters). Since the outside atmospheric pressure is applied to the backside of the diaphragm, via a vent tube, the transmitter measures pressure relative to ambient barometric pressure. All of the Type 4262A transmitters up to pressures of 35 barG (500 psiG) are of vented gauge type.

Sealed gauge pressure transmitters

Unlike vented gauge, sealed gauge pressure transmitters do not have a vent tube into the reference cavity of the silicon sensing element. For these types the sensing element is sealed with a vacuum on the reference side and its zero output reading electronically elevated to simulate a reference to one nominal atmosphere (hence the higher IP rating than vented gauge type transmitters). This is fine for applications with higher pressures where the effects of daily fluctuations in the actual atmospheric pressure will not induce unacceptable errors in the measurement being made. All of the Type 4262A transmitters with pressures at 50 barS (750 psiS) and above are of sealed gauge type.

¹⁾ Pro rate for pressures below 1 bar

²⁾ IP64 for transmitters with Cal-Adjust option (see page 7) and vent tube (see explanation above)

Ordering keyPlease use the web configurator at www.kistler.com/prt to construct your valid 16-digit type number transmitter.**Type 4262A**

| Pressure range | | | Pressure units | | Pressure connector | | Electrical connector | |
|----------------|---------------|------------|--------------------------------------|----------|---|----------|--|----------|
| barG | psiG | | psi | A | 7/16-20 UNF-2B, Female, per SAE J1926 | A | Integral Cable | A |
| 0.1 | 1.5 | 1D5 | bar | B | 1/4-18 NPT, Male | B | MIL-DTL-26482 | B |
| 0.17 | 2.5 | 2D5 | kPa | C | 1/4-18 NPT, Female | C | DIN 43650A | D |
| 0.2 | 3 | 3D0 | Torr | D | 1/4 AN 7/16-20 UNF-2A, Male, per SAE J514 | D | Lumberg M12 | E |
| 0.35 | 5 | 5D0 | inHg @ 0°C | E | G1/4 BSP, Female | E | Cable length See page 7 | |
| 0.5 | 7.5 | 7D5 | mmHg @ 0°C | F | G1/4B BSP, Male | F | Wiring options See page 10 to 13 | |
| 0.7 | 10 | 010 | inH ₂ O @ 4°C | G | 1/8-27 NPT, Male | G | Certification | |
| 1 | 15 | 015 | mH ₂ O @ 4°C | H | 7/16-20 UNJF-3A, Male, per AS 4395 | K | No calibration certificate | 0 |
| 1.7 | 25 | 025 | Output type See page 6 & 7 | | M10 x 1, Male | L | With calibration certificate | 1 |
| 2 | 30 | 030 | | | 7/16-20 UNF-2A, Male | M | Zone 0 (incl. cal. cert.) | A |
| 3.5 | 50 | 050 | | | 1/8-27 NPT, Female | N | Zone 2 (incl. cal. cert.) | B |
| 4 | 60 | 060 | | | G1/2B BSP, Male, per EN 837-1 | R | | |
| 5 | 75 | 075 | | | | | | |
| 7 | 100 | 100 | | | | | | |
| 10 | 150 | 150 | | | | | | |
| 14 | 200 | 200 | | | | | | |
| 20 | 300 | 300 | | | | | | |
| 35 | 500 | 500 | | | | | | |
| 50 | 750 | 750 | | | | | | |
| 70 | 1,000 | 1K0 | | | | | | |
| 100 | 1,500 | 1K5 | | | | | | |
| 140 | 2,000 | 2K0 | | | | | | |
| 200 | 3,000 | 3K0 | | | | | | |
| 350 | 5,000 | 5K0 | | | | | | |
| -1 ... 1 | -14.7 ... 15 | C01 | | | | | | |
| -1 ... 2 | -14.7 ... 30 | C02 | | | | | | |
| -1 ... 7 | -14.7 ... 100 | C03 | | | | | | |
| -1 ... 4 | -14.7 ... 60 | C04 | | | | | | |
| -1 ... 9 | -14.7 ... 130 | C05 | | | | | | |
| -0.2 ... 0.3 | -3 ... 4.5 | C06 | | | | | | |
| -1 ... 16 | -14.7 ... 230 | C07 | | | | | | |
| -1 ... 1.7 | -14.7 ... 25 | C08 | | | | | | |
| -0.07 ... 1 | -1 ... 15 | C09 | | | | | | |
| ±0.7 | ±10 | B01 | | | | | | |
| ±0.2 | ±3 | B02 | | | | | | |
| ±0.17 | ±2.5 | B03 | | | | | | |

See page 5 for nom. ranges in other units

Mating connector (optional, see page 7)

- MIL-DTL-26482, mating connector 1500A90K02
- DIN 43650A, mating connector 1500A90K04
- Lumberg M12, mating connector 1500A90K05

Mating connector with integral cable (optional, see page 7)

- MIL-DTL-26482 to Pigtail 1798AK02SP
- DIN 43650A to Pigtail 1798AK04SP
- Lumberg M12 to Pigtail 1798AK05SP

Pressure adaptors (optional, see page 8 for more options)

- 7/16-20 UNF male to 1/4-18 NPT male 6572A1
- 7/16-20 UNF male to 7/16-20 UNF male 6572A2
- 7/16-20 UNF male to 1/8-27 NPT male 6572A3

Pressure units and pressure range options

| | Pressure units | | | | | | | | |
|----------------|----------------|----------------|----------------|--------------|-----------------|-----------------|-------------------------------|------------------------------|------------|
| | A psi | B bar | C kPa | D Torr | E inHg @ 0°C | F mmHg @ 0°C | G inH ₂ O @ 4°C | H mH ₂ O @ 4°C | |
| Pressure range | 1D5 | 1.5 | 0.1 | 10 | 75 | 3 | 75 | 40 | 1 |
| | 2D5 | 2.5 | 0.17 | 17 | 125 | 5 | 125 | 70 | 1.7 |
| | 3D0 | 3 | 0.2 | 20 | 150 | 6 | 150 | 80 | 2 |
| | 5D0 | 5 | 0.35 | 35 | 250 | 10 | 250 | 140 | 3.5 |
| | 7D5 | 7.5 | 0.5 | 50 | 375 | 15 | 375 | 200 | 5 |
| | 010 | 10 | 0.7 | 70 | 525 | 20 | 525 | 280 | 7 |
| | 015 | 15 | 1 | 100 | 750 | 30 | 750 | 400 | 10 |
| | 025 | 25 | 1.7 | 170 | | 50 | 1,250 | 680 | 17 |
| | 030 | 30 | 2 | 200 | | 60 | 1,500 | 800 | 20 |
| | 050 | 50 | 3.5 | 350 | | 100 | 2,500 | 1,400 | 35 |
| | 060 | 60 | 4 | 400 | | 120 | 3,000 | 1,600 | 40 |
| | 075 | 75 | 5 | 500 | | 150 | 3,750 | 2,000 | 50 |
| | 100 | 100 | 7 | 700 | | 200 | 5,000 | 2,750 | 70 |
| | 150 | 150 | 10 | 1,000 | | 300 | 7,500 | 4,000 | 100 |
| | 200 | 200 | 14 | 1,400 | | 400 | 10,000 | 5,500 | 140 |
| | 300 | 300 | 20 | 2,000 | | 600 | 15,000 | 8,000 | 200 |
| | 500 | 500 | 35 | 3,500 | | 1,000 | 25,000 | 14,000 | 350 |
| | 750 | 750 | 50 | 5,000 | | 1,500 | 37,500 | 20,000 | 500 |
| | 1K0 | 1,000 | 70 | 7,000 | | 2,000 | 50,000 | 27,500 | 700 |
| | 1K5 | 1,500 | 100 | 10,000 | | 3,000 | 75,000 | 40,000 | 1,000 |
| | 2K0 | 2,000 | 140 | 14,000 | | 4,000 | 100,000 | 55,000 | 1,400 |
| | 3K0 | 3,000 | 200 | 20,000 | | 6,000 | 150,000 | 80,000 | 2,000 |
| | 5K0 | 5,000 | 350 | 35,000 | | 10,000 | 250,000 | 140,000 | 3,500 |
| | C01 | -14.7 ... 15 | -1 ... 1 | -100 ... 100 | | -29.4 ... 30 | -750 ... 750 | -400 ... 400 | -10 ... 10 |
| | C02 | -14.7 ... 30 | -1 ... 2 | -100 ... 200 | | -29.4 ... 60 | -750 ... 1,500 | -400 ... 800 | -10 ... 20 |
| | C03 | -14.7 ... 100 | -1 ... 7 | -100 ... 700 | | -29.4 ... 200 | -750 ... 5,000 | -400 ... 2,750 | -10 ... 70 |
| C04 | -14.7 ... 60 | -1 ... 4 | -100 ... 400 | | -29.4 ... 120 | -750 ... 3,000 | -400 ... 1,600 | -10 ... 40 | |
| C05 | -14.7 ... 130 | -1 ... 9 | -100 ... 900 | | -29.4 ... 460 | -750 ... 6,750 | -400 ... 3,600 | -10 ... 90 | |
| C06 | -3 ... 4.5 | -0.2 ... 0.3 | -20 ... 30 | | -6 ... 9 | -150 ... 225 | -80 ... 120 | -2 ... 3 | |
| C07 | -14.7 ... 230 | -1 ... 16 | -100 ... 1,600 | | -29.4 ... 260 | -750 ... 12,000 | -400 ... 6,400 | -10 ... 160 | |
| C08 | -14.7 ... 25 | -1 ... 1.7 | -100 ... 170 | | -29.4 ... 50 | -750 ... 1,250 | -400 ... 680 | -10 ... 17 | |
| C09 | -1 ... 15 | -0.07 ... 1 | -7 ... 100 | | -2 ... 30 | -50 ... 750 | -28 ... 400 | -0.7 ... 10 | |
| B01 | -10 ... 10 | -0.7 ... 0.7 | -70 ... 70 | | -20 ... 20 | -525 ... 525 | -280 ... 280 | -7 ... 7 | |
| B02 | -3 ... 3 | -0.2 ... 0.2 | -20 ... 20 | | -6 ... 6 | -150 ... 150 | -80 ... 80 | -2 ... 2 | |
| B03 | -2.5 ... 2.5 | -0.17 ... 0.17 | -17 ... 17 | | -5 ... 5 | -125 ... 125 | -70 ... 70 | -1.7 ... 1.7 | |

4262A_003-388e-04_21

Output type options

Kistler pressure transmitters of Type 4262A... are available with three types of electrical output:

- Millivolt output (mV)
- Current output (4 to 20 mA)
- Voltage output (VDC)

The table below, shows the ordering codes for the pressure transmitter's output type: A summary of the outputs and when they are best used follows.

| Output | Code |
|--|------|
| mV ¹⁾ | A |
| 4-20 mA ¹⁾ | C |
| 4-20 mA, Cal-Adjust | E |
| 0.5 ... 4.5 VDC (3-wire) ¹⁾ | I |
| 0.5 ... 4.5 VDC (3-wire), Cal-Adjust | K |
| -5 ... 5 VDC (3-wire) | 8 |
| -5 ... 5 VDC (3-wire), Cal-Adjust | 4 |
| -5 ... 5 VDC (4-wire) ¹⁾ | U |
| -5 ... 5 VDC (4-wire), Cal-Adjust | W |
| 0 ... 5 VDC (3-wire) | 6 |
| 0 ... 5 VDC (3-wire), Cal-Adjust | 1 |
| 0 ... 5 VDC (4-wire) ¹⁾ | X |
| 0 ... 5 VDC (4-wire), Cal-Adjust | Z |
| 0.1 ... 5 VDC (3-wire) ¹⁾ | L |
| 0.1 ... 5 VDC (3-wire), Cal-Adjust | N |
| 1 ... 5 VDC (3-wire) | J |
| 1 ... 5 VDC (3-wire), Cal-Adjust | M |
| 1 ... 6 VDC (3-wire) ¹⁾ | F |
| 1 ... 6 VDC (3-wire), Cal-Adjust | H |
| 0 ... 10 VDC (3-wire) | 7 |
| 0 ... 10 VDC (3-wire), Cal-Adjust | 2 |
| 0 ... 10 VDC (4-wire) ¹⁾ | R |
| 0 ... 10 VDC (4-wire), Cal-Adjust | T |

¹⁾ Hazardous area certification available for this option

mV output

The full scale output signal of pressure transmitters with mV output is directly proportional to the supply voltage (5 to 15 VDC) and adds up to 5 or 10 mV per 1 V of supply voltage (mV output depends on pressure range, check web configurator). Transmitters with mV output are, due to less built-in electronics (e.g. amplifiers, etc.), the most economical option. The output of mV transmitters will fluctuate with the excitation voltage, therefore it's strongly recommended to use a regulated power supply. Transmitters with mV output signal should, due to the low output signal, not be located in electrically noisy environments and cable lengths between transmitter and readout instrument kept relatively short.

This information corresponds to the current state of knowledge. Kistler reserves the right to make technical changes. Liability for consequential damage resulting from the use of Kistler products is excluded.

V output

Voltage output transmitters include integral signal conditioning which provides a much higher output than a pressure transmitter with mV output. The output of voltage transmitters do not depend on the excitation voltage (as the mV output types do) and can therefore be used with unregulated power supplies. Supply voltage (VDC) and current drain (mA) depends on the voltage output chosen (see electrical specification on page 3). Voltage output transmitters are, because of the higher output signal, not as susceptible to electrical noise as the mV transmitters and can therefore be used in much more industrial environments.

4 to 20 mA output

Loop powered Kistler transmitters with mA output use an industry-standard 4-20 mA output mode. When using a 4-20 mA transmitter, zero pressure will produce a 4 mA output current and full scale pressure a 20 mA output current. The output from mA transmitters is independent of the supply voltage (9 to 28 VDC). However, it's important to ensure that the power supply is able to provide sufficient voltage for all the equipment in the current loop. Since a mA signal is least affected by electrical noise (good noise immunity EMI/RFI) and resistance in the signal wires, these transmitters are best used in applications where long cable lengths are required. For battery driven applications, attention must be paid to the rather large output current signal when operating at full pressure. Most readout instrumentation devices (e.g. DAQ, Display, etc.) have a built-in load resistance that converts the current signal (4-20 mA) to a voltage, which is then processed by the instrumentation's A/D converter or microprocessor. The voltage drop across the load resistance must be subtracted from the available power supply in order to determine the net voltage available for powering the pressure transmitter. The loop resistance chart below shows the allowed voltage supply V_S (of the power supply unit) for a given load resistance R_L .

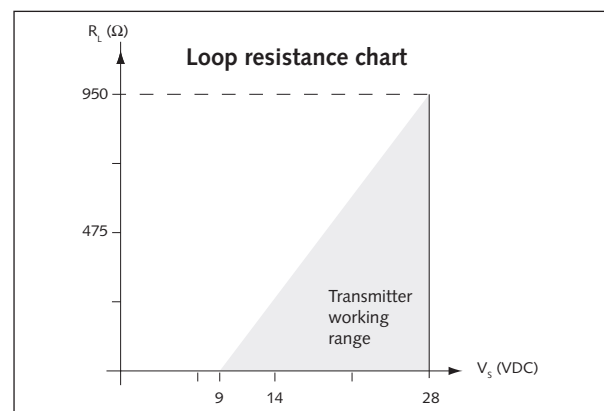

The min. required working voltage is given by:

$$V_S = 9 \text{ V} + (I_{\text{max}} \times R_L) = 9 \text{ V} + (0.02 \text{ A} \times R_L)$$

Cal-Adjust

Pressure transmitters with Cal-Adjust option allow access to potentiometers to adjust zero and span after the unit is fully assembled. The potentiometers can be accessed by rotating a blue rubber plug mounted on the side of the transmitter. Once

adjusted, original supplied calibration certificates are no longer valid. Cal-Adjust transmitters are IP64 compliant due to the rubber plug.

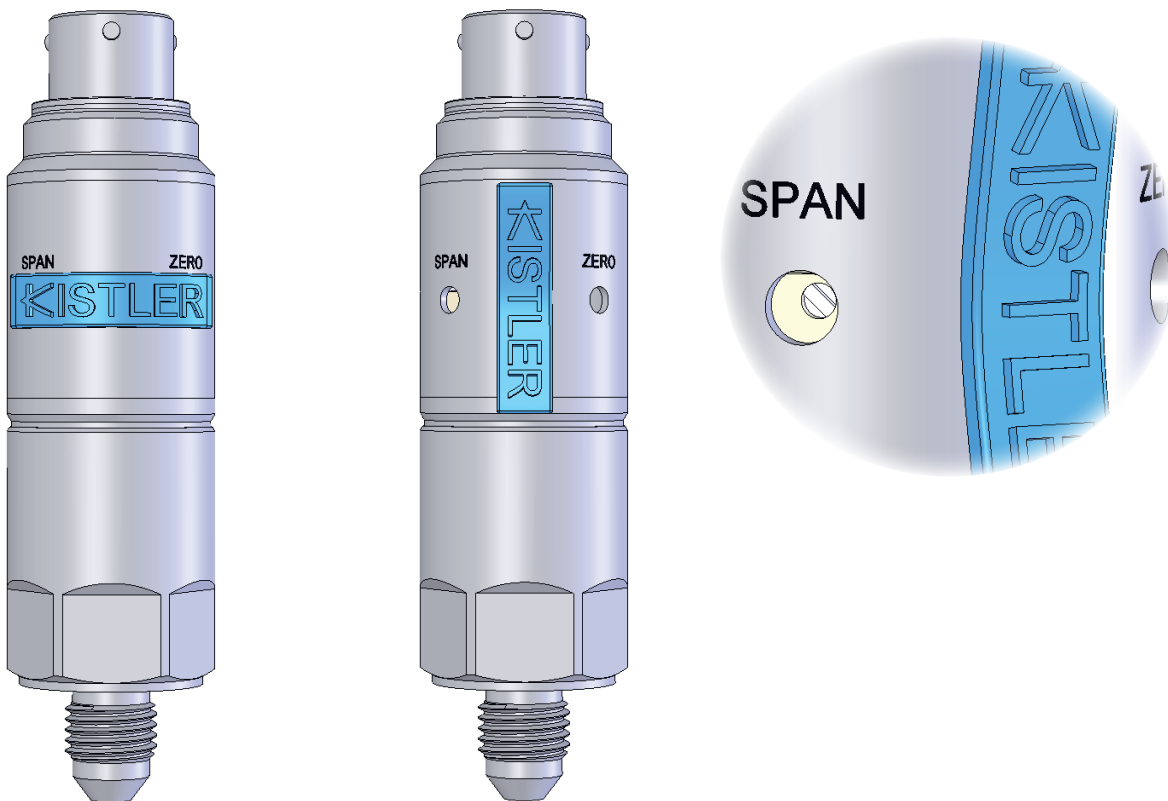

Cable length options

Below table shows the ordering codes for the cable length on electrical connector option A (Integral cable).

| Code | 01 | 02 | 03 | ... | 97 | 98 | 99 |
|-------------|-----|-----|-----|-----|------|------|------|
| Length (ft) | 1 | 2 | 3 | ... | 97 | 98 | 99 |
| Length (m) | 0.3 | 0.6 | 0.9 | ... | 29.6 | 29.9 | 30.2 |

Code "00" needs to be selected for the cable length on electrical connector options B (MIL-DTL-26482), D (DIN 43650A) and E (Lumberg M12) since no integral cable option is offered with these connector options.

Mating connector with and without integral cable (optional)

The mating connector of the electrical connector options B, D and E need to be ordered separately. The corresponding 1500A90K... Type numbers are listed on page 4.

Mating connectors with integral cables can be ordered optionally (only available for electrical connector options B, D and E). The corresponding 1798AK... Type numbers are listed on page 4 (order length in m).

Pressure (female) and electrical connector options (all dimensions in mm [in.])

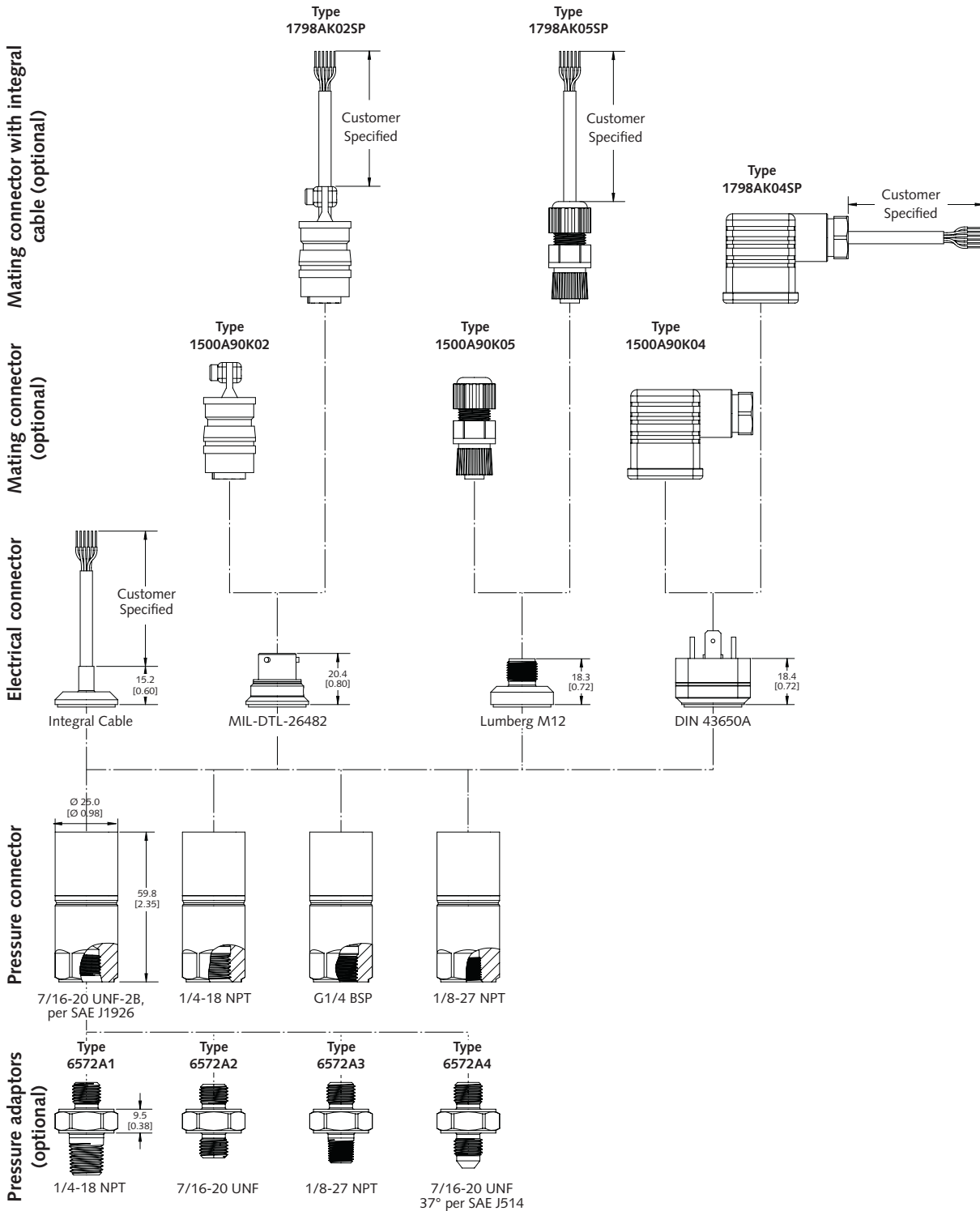

4262A_003-388e-04_21



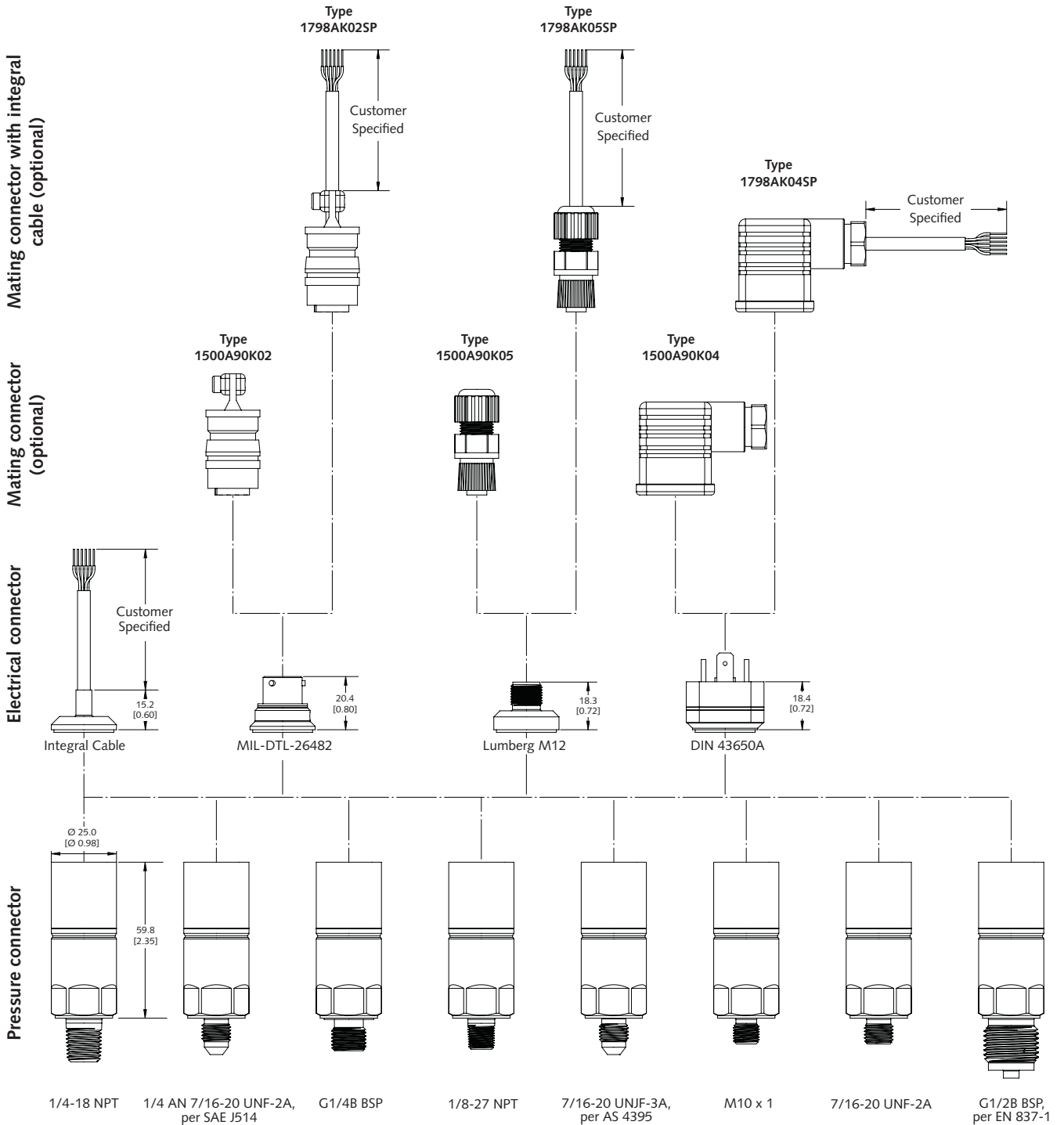







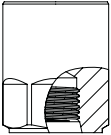

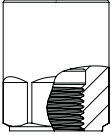
Pressure (male) and electrical connector options (all dimensions in mm [in.])

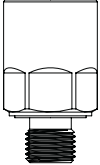

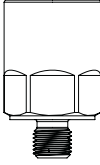
4262A_003-388e-04_21

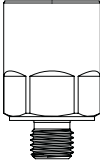
Sealing accessories

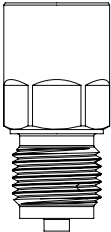
Certain pressure connector options include some common seal options as shown below. It is however the responsibility of the customer to ensure the media compatibility of the seal materials as well as determine the best sealing method for the corresponding application.

| Pressure connector | Included sealing accessories | |
|---|---|--|
| Option A 7/16-20 UNF-2B, Female, per SAE J1926  | Bonded seal  Size: 7/16" ID Materials: Steel/Buna N Durometer: 85, Shore A | O-ring  Size: AS568 -904 Material: Buna N Durometer: 70, Shore Option A |
| Option E G1/4 BSP, Female  | Bonded seal  Size: B.S.P. 1/4" Materials: Steel/Buna N Durometer: 70, Shore A | |
| Option F G1/4B BSP, Male  | Elastoc seal ring  Size: B.S.P. 1/4" Materials: Buna N Durometer: 90, Shore A | |
| Option L M10 x 1, Male  | Bonded seal  Size: 10 mm ID Materials: Steel/Buna N Durometer: 70, Shore A | O-ring  Size: 8.1 mm ID x 1.6 mm Thk. Material: Buna N Durometer: 70, Shore A |
| Option M 7/16-20 UNF-2A, Male  | Bonded seal  Size: 7/16" ID Materials: Steel/Buna N Durometer: 85, Shore A | O-ring  Size: AS568 -904 Material: Buna N Durometer: 70, Shore A |
| Option R G1/2B BSP, Male, per EN 837-1  | Sealing washer  Size: G1/2 per EN 837-1 Material: Copper | |

4262A_003-388e-04_21

Wiring options

The table below gives an overview of the different wiring options available for each combination of electrical connector and electrical output. The following pages then show the details on each of the wiring options.

| | | | Electrical connector | | | | | |
|-------------|------------|---------------|----------------------|---------------|---------------------|---------------------|------------|------------|
| | | | A | B | D | E | | |
| | | | Int. Cable | MIL-DTL-26482 | DIN 43650A | Lumberg M12 | | |
| Output type | A | mV | – | Q, S | T, V | – | – | |
| | C | 4 ... 20 mA | – | O | P | R | R | |
| | E | 4 ... 20 mA | Cal-Adjust | – | O | P | R | R |
| | F | 1 ... 6 V | 3-wire | C, D, E | L, M, N, U | X, Y | M, U, X, Y | |
| | H | 1 ... 6 V | Cal-Adjust | 3-wire | C, D, E | L, M, N, U | X, Y | M, U, X, Y |
| | I | 0.5 ... 4.5 V | 3-wire | C, D, E | L, M, N, U | X, Y | M, U, X, Y | |
| | J | 1 ... 5 V | 3-wire | C, D, E | L, M, N, U | X, Y | M, U, X, Y | |
| | K | 0.5 ... 4.5 V | Cal-Adjust | 3-wire | C, D, E | L, M, N, U | X, Y | M, U, X, Y |
| | L | 0.1 ... 5 V | 3-wire | C, D, E | L, M, N, U | X, Y | M, U, X, Y | |
| | M | 1 ... 5 V | Cal-Adjust | 3-wire | C, D, E | L, M, N, U | X, Y | M, U, X, Y |
| | N | 0.1 ... 5 V | Cal-Adjust | 3-wire | C, D, E | L, M, N, U | X, Y | M, U, X, Y |
| | R | 0 ... 10 V | 4-Wire | A, B | F, G, H, I, J, K, W | – | G, I, K, W | |
| | T | 0 ... 10 V | Cal-Adjust | 4-Wire | A, B | F, G, H, I, J, K, W | – | G, I, K, W |
| | U | -5 ... 5 V | 4-Wire | A, B | F, G, H, I, J, K, W | – | G, I, K, W | |
| | W | -5 ... 5 V | Cal-Adjust | 4-Wire | A, B | F, G, H, I, J, K, W | – | G, I, K, W |
| | X | 0 ... 5 V | 4-Wire | A, B | F, G, H, I, J, K, W | – | G, I, K, W | |
| | Z | 0 ... 5 V | Cal-Adjust | 4-Wire | A, B | F, G, H, I, J, K, W | – | G, I, K, W |
| | 1 | 0 ... 5 V | Cal-Adjust | 3-wire | C, D, E | L, M, N, U | X, Y | M, U, X, Y |
| | 2 | 0 ... 10 V | Cal-Adjust | 3-wire | C, D, E | L, M, N, U | X, Y | M, U, X, Y |
| | 4 | -5 ... 5 V | Cal-Adjust | 3-wire | C, D, E | L, M, N, U | X, Y | M, U, X, Y |
| 6 | 0 ... 5 V | 3-wire | C, D, E | L, M, N, U | X, Y | M, U, X, Y | | |
| 7 | 0 ... 10 V | 3-wire | C, D, E | L, M, N, U | X, Y | M, U, X, Y | | |
| 8 | -5 ... 5 V | 3-wire | C, D, E | L, M, N, U | X, Y | M, U, X, Y | | |

Shunt

Kistler pressure transmitters of Type 4262A... with voltage output are available with a Shunt option. These transmitters contain an internal shunt calibration resistor which provides a simulated output of 80% of full scale output when the corresponding cable wire or connector pin is shorted to (–) Supply. With this option, customers can periodically check the transmitter's output and cable connection without exposing the transmitter to an actual pressure signal. Specification valid if applied pressure $\leq 20\%$ FS. If applied pressure is $>20\%$ FS the output shift may be less due to electrical limitations of the sensor.

Remote Supply Monitoring

On long cable lengths there might be a supply voltage drop across the supply wires. In such cases, wiring option S and V allows monitoring the supply voltage of pressure transmitters with mV output right at the sensor. This optional feature allows determining the true supply voltage of the pressure transmitters and therefore allowing for correction of a low output pressure signal.

As an example, a 100 psi sensor with long cable seeing 100 psi with 10 mV/V output and 10 V supply might read 99 mV at the output. Without measuring the supply voltage right at the pressure transmitter, the conclusion would be that the pressure transmitter is measuring 99 psi. However, measuring the supply voltage right at the sensor would show a supply voltage of only 9.9 V, because of 0.1 V drop across supply wires, and therefore allows determining that the 99 mV at the output corresponds to 100 psi and not 99 psi.

Wiring options for electrical connector A (Integral cable)

The 6 conductor 24 AWG integral cable option is the preferred solution for T&M applications when uncoupling of the sensor from the wiring happens infrequently. The available cable length ranges from 0.3 m (1ft) to a maximum cable length of 30.2 m (99 ft), for more information on this please see page 7. The shield and any wire that is stated as 'not connected' in the tables below are always cut flush with the cable jacket.



Voltage output

| Wire color | 4-wire | | | 3-wire | |
|------------|-----------------|-----------------|-------------------|-------------------|-------------------|
| | Wiring option A | Wiring option B | Wiring option C | Wiring option D | Wiring option E |
| Red | (+) Supply | (+) Supply | (+) Supply | (+) Supply | (+) Supply |
| Blue | (-) Supply | (-) Supply | (-) Supply/Output | (-) Supply/Output | Shunt |
| Yellow | (+) Output | (+) Output | (+) Output | (+) Output | (+) Output |
| Green | (-) Output | (-) Output | Not connected | Not connected | (-) Supply/Output |
| Brown | Shunt | Not connected | Shunt | Not connected | Not connected |
| Black | Not connected | Not connected | Not connected | Not connected | (-) Supply/Output |
| Shield | Not connected | Not connected | Not connected | Not connected | Not connected |

mA and mV output

| Wire color | mA output | | mV | |
|------------|-------------------|-----------------|-----------------|--|
| | Wiring option O | Wiring option Q | Wiring option S | |
| Red | (+) Supply | (-) Supply | (+) Supply | |
| Blue | (-) Supply/Output | (-) Supply | (-) Supply | |
| Yellow | Not connected | (-) Output | (+) Output | |
| Green | Not connected | (+) Output | (-) Output | |
| Brown | Not connected | Not connected | (+) Supply | |
| Black | Case Ground | Not connected | (-) Supply | |
| Shield | Not connected | Not connected | Not connected | |

Wiring options for electrical connector B (MIL-DTL-26482)

Pressure transmitters with connector option B fully meet the military specification MIL-DTL-26482 for circular connectors. The quick disconnect circular connector uses a 3 pin bayonet coupling, is environmentally sealed (IP65) and can be used across the transmitter's full temperature range. Originally designed for military applications this connector is now commonly found in T&M applications requiring a rugged connector for harsh environments. Mating connectors, with or without integral cable, are available optionally (see page 7).

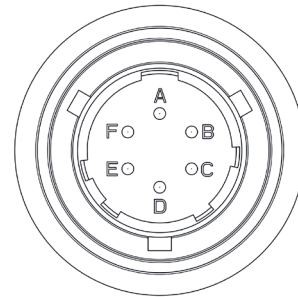

Voltage output

| Pin | 4-wire | | | | 1798AK02SP |
|-----|-----------------|-----------------|-----------------|-----------------|------------|
| | Wiring option F | Wiring option G | Wiring option H | Wiring option I | Wire color |
| A | (+) Supply | (+) Supply | (+) Supply | (+) Supply | Red |
| B | (+) Output | (+) Output | (-) Supply | (-) Supply | Blue |
| C | (-) Output | (-) Output | (+) Output | (+) Output | Yellow |
| D | (-) Supply | (-) Supply | (-) Output | (-) Output | Green |
| E | Shunt | Not connected | Shunt | Not connected | Black |
| F | Not connected | Not connected | Not connected | Not connected | Brown |
| N/C | – | – | – | – | Shield |

| Pin | 4-wire | | | 1798AK02SP |
|-----|-----------------|-----------------|-----------------|------------|
| | Wiring option J | Wiring option K | Wiring option W | Wire color |
| A | (+) Supply | (+) Supply | (+) Supply | Red |
| B | (-) Output | (-) Output | (-) Supply | Blue |
| C | (-) Supply | (-) Supply | (-) Output | Yellow |
| D | (+) Output | (+) Output | (+) Output | Green |
| E | Shunt | Not connected | Not connected | Black |
| F | Not connected | Not connected | Not connected | Brown |
| N/C | – | – | – | Shield |

| Pin | 3-wire | | | | 1798AK02SP |
|-----|-------------------|-------------------|-------------------|-------------------|------------|
| | Wiring option L | Wiring option M | Wiring option N | Wiring option U | Wire color |
| A | (+) Supply | (+) Supply | (+) Supply | (+) Supply | Red |
| B | (+) Output | (+) Output | (-) Supply/Output | (-) Supply/Output | Blue |
| C | (-) Supply/Output | (-) Supply/Output | (-) Supply/Output | (-) Supply/Output | Yellow |
| D | (-) Supply/Output | (-) Supply/Output | (+) Output | (+) Output | Green |
| E | Shunt | Not connected | Shunt | Not connected | Black |
| F | Not connected | Not connected | Not connected | Not connected | Brown |
| N/C | – | – | – | – | Shield |

mA and mV output

| Pin | mA | mV | | 1798AK02SP |
|-----|-------------------|-----------------|-----------------|------------|
| | Wiring option P | Wiring option T | Wiring option V | Wire color |
| A | (+) Supply | (+) Supply | (+) Supply | Red |
| B | Not connected | (+) Output | (+) Supply | Blue |
| C | (-) Supply/Output | (-) Output | (-) Supply | Yellow |
| D | Not connected | (-) Supply | (-) Supply | Green |
| E | Case ground | Case ground | (+) Output | Black |
| F | Not connected | Not connected | (-) Output | Brown |
| N/C | – | – | – | Shield |

Wiring options for electrical connector D (DIN 43650A)

Using pressure transmitters with a standardized DIN 43650A connector permits industry interchangeability and includes the ability for the user to wire the connector into existing installations. Pressure transmitters with a DIN 43650A connector may be used in T&M applications up to ambient temperatures of 125°C (257°F) and offers the option to couple/uncouple the sensor from the cabling. Mating connectors, with or without integral cable, are available optionally (see page 7).

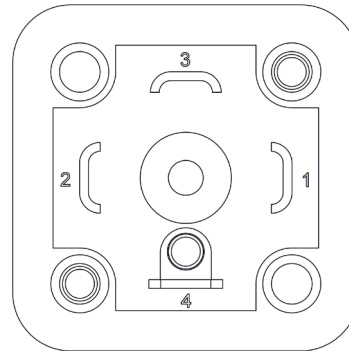

Voltage and mA output

| Pin | Voltage 3-wire | | mA Wiring option R | 1798AK04SP Wire color |
|-----|-------------------|-------------------|-----------------------|--------------------------|
| | Wiring option X | Wiring option Y | | |
| 1 | (+) Supply | (-) Supply/Output | (+) Supply | Red |
| 2 | (-) Supply/Output | (+) Output | Not connected | Black |
| 3 | (+) Output | (+) Supply | (-) Supply/Output | Yellow |
| 4 | Case ground | Case ground | Case ground | Brown |
| N/C | – | – | – | Blue |
| N/C | – | – | – | Green |
| N/C | – | – | – | Shield |

Wiring options for electrical connector E (Lumberg M12)

Pressure transmitters with a Lumberg M12 connector offer, out of all the connector options of the 426xA series, the best environmental protection (up to IP67 depending on the mating connector specifications). However coupling and uncoupling of Lumberg M12 connectors takes, due to the threaded connection, longer than bayonet connectors (e.g. connector option B). Mating connectors, with or without integral cable, are available optionally (see page 7).

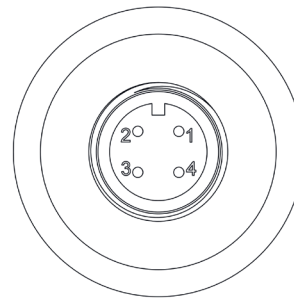

Voltage and mA output

| Pin | Voltage 4-Wire | | | | 1798AK05SP Wire color |
|-----|-----------------|-----------------|-----------------|-----------------|--------------------------|
| | Wiring option G | Wiring option I | Wiring option K | Wiring option W | |
| 1 | (+) Supply | (+) Supply | (+) Supply | (+) Supply | Red |
| 2 | (+) Output | (-) Supply | (-) Output | (-) Supply | Blue |
| 3 | (-) Output | (+) Output | (-) Supply | (-) Output | Yellow |
| 4 | (-) Supply | (-) Output | (+) Output | (+) Output | Green |
| N/C | – | – | – | – | Black |
| N/C | – | – | – | – | Brown |
| N/C | – | – | – | – | Shield |

| Pin | Voltage 3-Wire | | | | mA Wiring option R | 1798AK05SP Wire color |
|-----|-------------------|-------------------|-------------------|-------------------|-----------------------|--------------------------|
| | Wiring option M | Wiring option U | Wiring option X | Wiring option Y | | |
| 1 | (+) Supply | (+) Supply | (+) Supply | (-) Supply/Output | (+) Supply | Red |
| 2 | (+) Output | (-) Supply/Output | (-) Supply/Output | (+) Output | Not connected | Blue |
| 3 | (-) Supply/Output | (-) Supply/Output | (+) Output | (+) Supply | (-) Supply/Output | Yellow |
| 4 | (-) Supply/Output | (+) Output | Case ground | Case ground | Case ground | Green |
| N/C | – | – | – | – | – | Black |
| N/C | – | – | – | – | – | Brown |
| N/C | – | – | – | – | – | Shield |

Sensor marking

All of the 426xA pressure transmitters are laser marked with type number, serial number, manufacturing date, pressure range, power supply, output type and wiring details.

In addition, Hazardous Area approved models include all of the mandatory information required by the corresponding norm.

PRT 426xA marking (Standard)

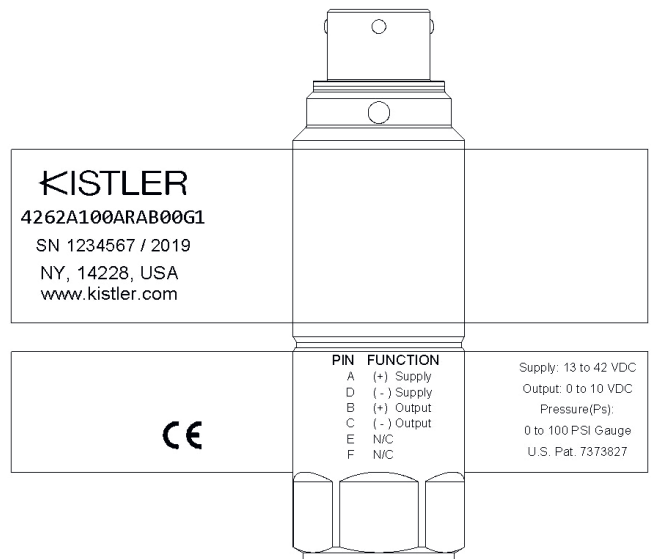

PRT 426xA marking (Zone 0)

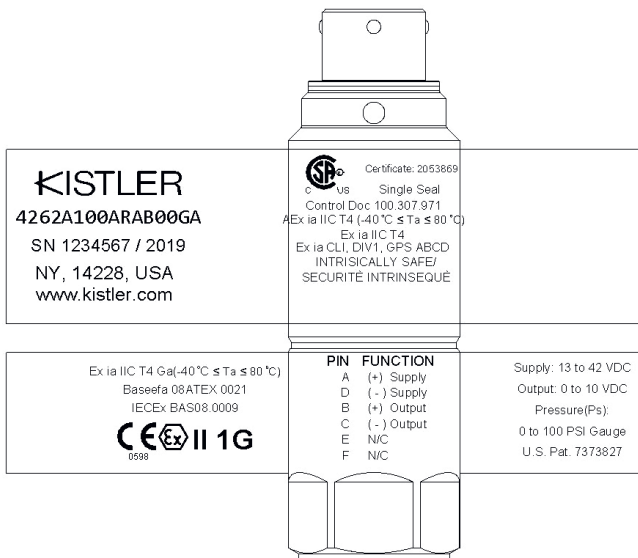

PRT 426xA marking (Zone 2)

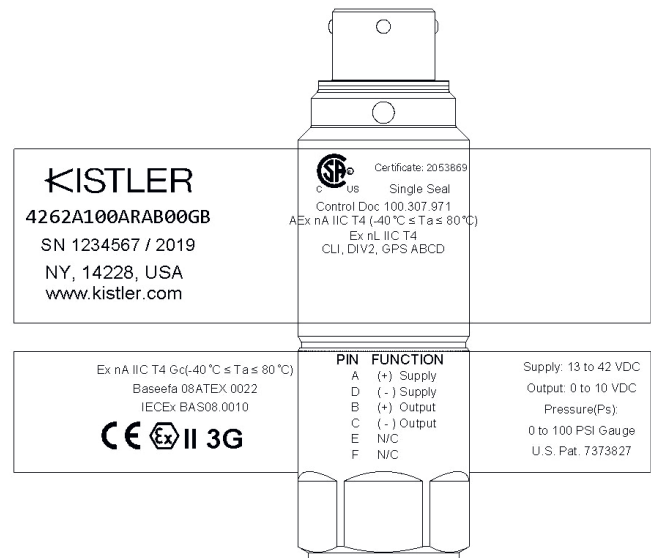

4262A_003-388e-04_21

Hazardous area – Zener barrier (optional)

Pressure transmitters intended for use in Zone 0 Hazardous Classified Areas must use a suitable zener barrier being less than the entity parameters shown in the manual for the pressure transmitters of Type 4260A, 4262A and 4264A series. For Zone 2, the same entity parameters apply but use of a zener barrier is not required.



The charts below show the use of Kistler's Zener Barriers Types 5252A1 and 5252A2 with the pressure transmitters of Type 4260A, 4262A and 4264A series. The zener barrier type and quantity to be used for each 426xA depends on the pressure transmitter's output type.

PRT 426xA with mA output

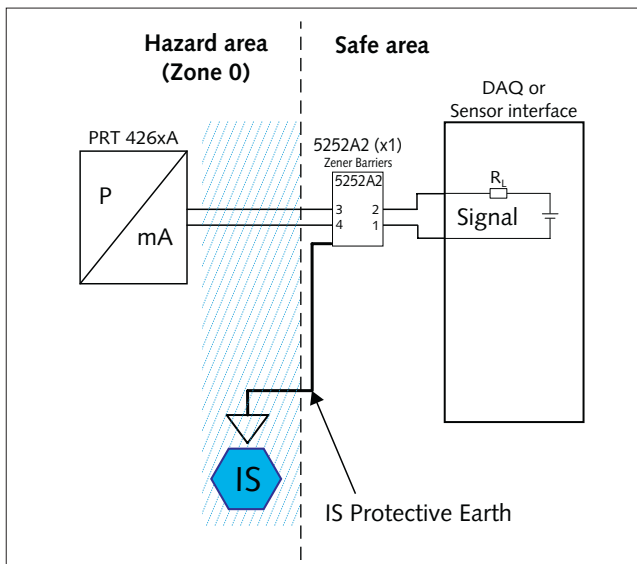

PRT 426xA with mV output

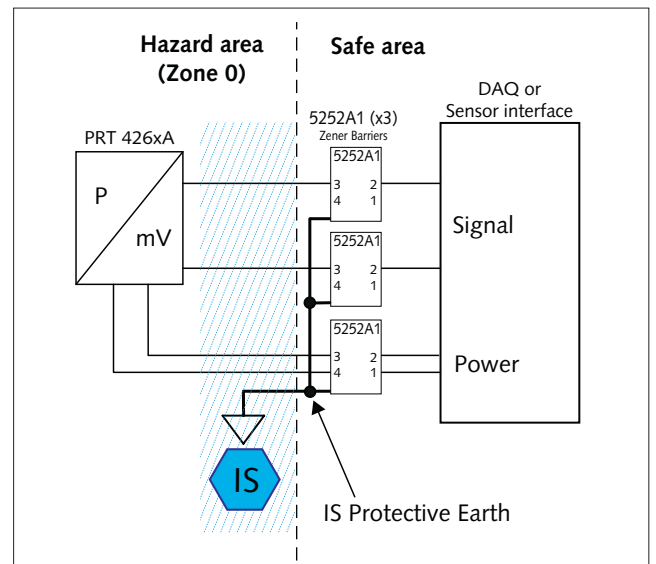

PRT 426xA with V output (3-wire)

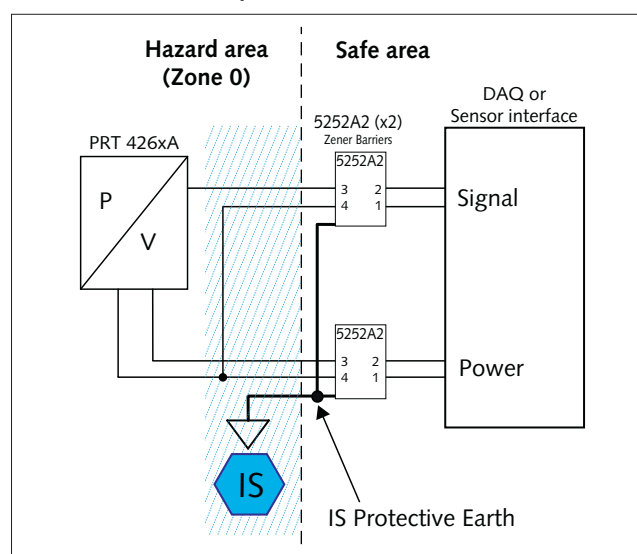

PRT 426xA with V output (4-wire)

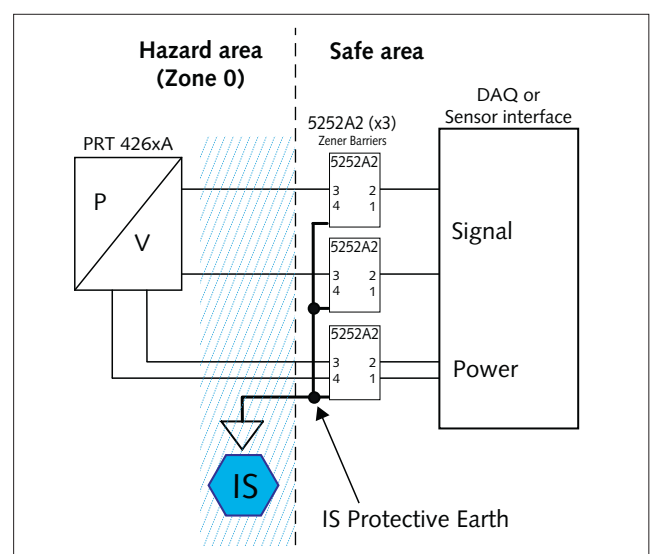

4262A_003-388e-04_21

Certification – Calibration data

Each Type 4262A pressure transmitter is fully tested over both pressure and temperature to ensure compliance to the specifications. This data is available for each transmitter and is traceable to ISO 17025 and NIST.

Calibration certificates are delivered with intrinsically safe Type 4262A transmitters. For standard Type 4262A transmitters the calibration certificate needs to be ordered separately.



measure. analyze. innovate.

Piezoresistive Pressure Sensor Calibration

| | | | | |
|-----------------------|------------------|-----------------------|----------------------|--------|
| Type | 4262A150AXCB00W1 | Span | V | 4.991 |
| Serial Number | 2050735 | Offset | V | 0.001 |
| Pressure Range | 0 to 150 PSI | Supply Voltage | V | 15.001 |
| Reference | Gauge | Calibrated By | Dan Wolf | |
| Test Condition | New | Date/Time | 6/28/2007 8:08:00 AM | |

| Non-Linearity, Hysteresis, and Repeatability (NLHR) | | | | Summary: Passed | | |
|---|------------|----------------|------------|---------------------|------------|-----------|
| Pressure (PSI) | Output (V) | BFSL Error (%) | Limits (%) | Accuracy (NLHR) | Limits (%) | Pass/Fail |
| 0.0 | 0.0011 | -0.010 | ± 0.1 | Temp -10°C To 50°C | ± 0.1 | Passed |
| 37.5 | 1.2491 | -0.002 | ± 0.1 | Temp -40°C To 125°C | ± 1.0 | Passed |
| 75.0 | 2.4979 | 0.017 | ± 0.1 | Span (5 V nom.) | ± 1.5 | Passed |
| 112.5 | 3.7455 | 0.013 | ± 0.1 | Offset (0 V nom.) | ± 1.0 | Passed |
| 150.0 | 4.9916 | -0.018 | ± 0.1 | | | |
| 75.0* | 2.4962 | -0.034 | ± 0.1 | | | |
| 0.0* | -0.0007 | -0.036 | ± 0.1 | | | |

*** Decreasing Pressure**

| Temperature Performance | | | |
|-------------------------|----------------|------------------|--|
| Temperature (°C) | Span Error (%) | Offset Error (%) | |
| -40.2 | -0.320 | -0.089 | |
| -19.1 | -0.351 | -0.069 | |
| -9.3 | -0.249 | -0.034 | |
| -0.5 | -0.233 | 0.005 | |
| 25.0 | 0.000 | 0.000 | |
| 48.5 | 0.112 | -0.138 | |
| 77.5 | 0.131 | -0.105 | |
| 100.5 | 0.094 | -0.018 | |
| 124.7 | -0.098 | 0.170 | |

| Error Calculation | Unit |
|---|--------|
| NLHR limits are based on | % span |
| Temperature Performance limits are based on | % span |
| Span & Offset limits are based on | % span |

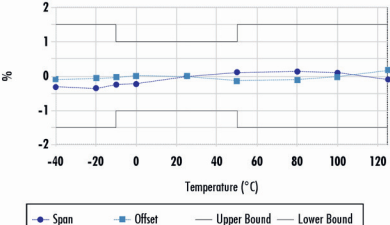

| Reference Equipment | | Electrical Interface (MIL-C-26482) | |
|---------------------|------------|------------------------------------|------------|
| Type | S/N | Pin/Wire | Function |
| Agilent 34970A | MY44021689 | A | (+) Supply |
| Mensor Series 600 | 610435 | B | (-) Supply |
| | | D | (+) Output |
| | | C | (-) Output |
| | | E | N/C |
| | | F | N/C |
| | | Case | N/C |

This Sensor was calibrated per Kistler Test Procedure 680-0000-701 using comparison technique against a Kistler Working Standard. Kistler Working Standards are periodically calibrated against a Kistler Reference Standard System which in turn is periodically recertified and traceable to the National Institute of Standards and Technology (NIST). It is derived from accepted values of natural physical constants according to the International System of Units (SI). Kistler's calibration system meets or exceeds the requirements of MIL-STD-45662A, ANSI/NCSL Z540, ISO 9001:2000 and ISO/IEC 17025. Kistler is accredited to ISO/IEC 17025 by ACLASS, Assured Calibration and Laboratory Accreditation Select Services. Certificate numbers are on file at Kistler and may be requested in writing. Estimated uncertainty of this calibration is ±0.05 % of pressure range for voltage output sensors or ±0.12% of pressure range for current output sensors with respect to reference standard. This certificate shall not be reproduced, except in full, without written approval of Kistler Instrument Corporation.

Kistler Instrument Corp.
75 John Glenn Drive
Amherst, NY 14228-2171

Tel 1-888-KISTLER
Fax 1-716-691-5226
info.us@kistler.com

ISO 9001 CERTIFIED QUALITY SYSTEM
ISO 17025 Accredited Calibration Laboratory

040-0090-001
Page 2 of 2

www.kistler.com

Accuracy clearly stated: Linearity shown in 25% intervals

Thermal error: Span and offset shift with temperature presented in both tabular and graphical form

NIST traceability information and reference equipment stated to ISO and other standards

Summary of pass/fail test results stated against the standard specification

Actual graphical representation of sensor performance over temperature

Electrical wiring connections are marked clearly on sensor and calibration certificate

4262A_003-388e-04.21